

SOUTHERN CROSS[®]
SXSS
ELECTRO-SUBMERSIBLE
SLURRY PUMP



SXSS

ELECTRO-SUBMERSIBLE SLURRY PUMPS

Durable, electro-submersible slurry pumps. Versatile and rugged solution for the transfer of abrasive and high density slurries in mining, civil construction, industry and other heavy duty applications.

VERSATILE HEAVY DUTY SOLUTION

Southern Cross SXSS series are a heavy duty, electro-submersible slurry pumps designed to handle a wide range of slurries and abrasive particles in submersible applications in mining and industry.

SXSS pumps feature a rugged construction using the highest quality materials to ensure reliable performance and excellent service life. The high quality electric motors incorporate multiple protection features to detect the ingress of water or excessive temperatures to shut off the pump and prevent damage.

Pumps are available in 72 different models in sizes ranging from 80mm to 400mm (3.15 - 16 inches) discharge and are capable of flow rates from 23 to 2400 cubic metres per hour (100-10560USGPM) and heads up to 64 metres (210ft). Pumps can pass solids up to 60mm (2.4 inches) in diameter enabling them to transfer dense slurries with large abrasive particles.

LARGE CUT WATER CLEARANCE

The pump casing features a large cut water clearance which allows the easy passage of large solids and reduces wear and erosion to improve service life and prevent loss of efficiency.

INTEGRAL AGITATOR

The 27% chrome white iron agitator assists in the pumping of slurries by breaking up large particles and agitating high concentrations of solids.

HEAVY DUTY CONSTRUCTION

The pump casing, impeller, backplate and agitator are manufactured from high quality 27% chrome white iron. This extremely tough construction material can withstand continuous use in heavy duty applications and allows the SXSS pumps to transfer abrasive and dense slurries with minimal wear. The pumps feature a replaceable backplate allowing for simple servicing and easy replacement of worn components.

F CLASS MOTOR INSULATION

F class motor insulation is used to ensure reliable operation in heavy duty applications in temperatures up to +40°C (104°F). In applications where higher temperatures are expected, H class motor insulation can be used to allow operating temperatures up to +70°C (158°F).

SUPPORT FRAME AND STRAINER

A heavy duty mild steel frame with round base and strainer provide excellent stability and durability whilst preventing blockages.

SOUTHERN CROSS SXSS280-40-75 SUBMERSIBLE SLURRY PUMP





DOUBLE MECHANICAL SEAL

A double mechanical seal provides excellent shaft sealing between the electric motor and wet end. The seals are oil bath lubricated and feature carbon/ceramic seal faces in the wet end and tungsten ceramic faces in the drive end to provide excellent durability and service life across a wide range of duties and applications.

OIL CHAMBER LEAKAGE PROBE

The oil chamber incorporates a water leakage probe which detects when the water-to-oil ratio is too high and automatically shuts down the motor to prevent damage.

MOTOR FLOAT SWITCH

A float switch is located in the bottom of the motor to detect the ingress of water and shut down the motor to prevent damage due to shorting out.

MOTOR TEMPERATURE SENSORS

Temperature sensors are located in the motor stator to detect excessive temperatures and can shut down the motor to prevent damage due to overheating.

THRUST BEARING SENSORS

Temperature and moisture sensors are located in the motor thrust bearings to detect excessive temperatures and the ingress of water and shut down the motor to prevent bearing failure.

OPTIONAL EXTERNAL COOLING

Cooling jackets can be provided with external water supply in high temperature applications to keep motor temperature down and prevent excessive stator and bearing damage.

SXSS Submersible Slurry Pumps are available in 72 different models in sizes ranging from 80mm to 400 mm (3.15-16 inches) discharge and are capable of flow rates up to 2400 cubic metres per hour (100-10560UGPM).

PUMP PERFORMANCE SELECTION CHART (25-100m³/hr)

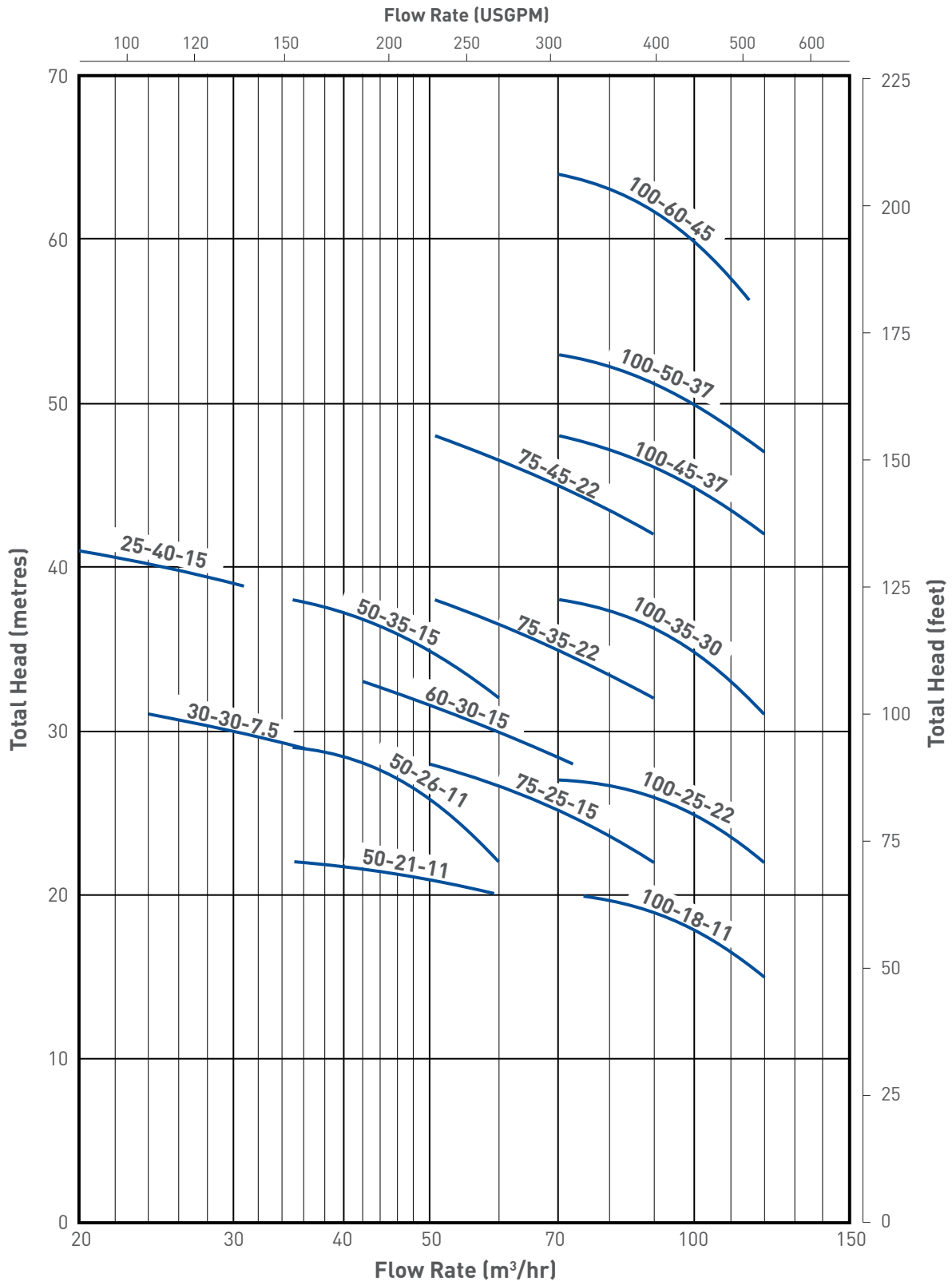

Performance curve is for clean, cold water only. Contact Pentair Southern Cross to discuss pump selections for specific applications.

PUMP PERFORMANCE SELECTION CHART (150-800m³/hr)

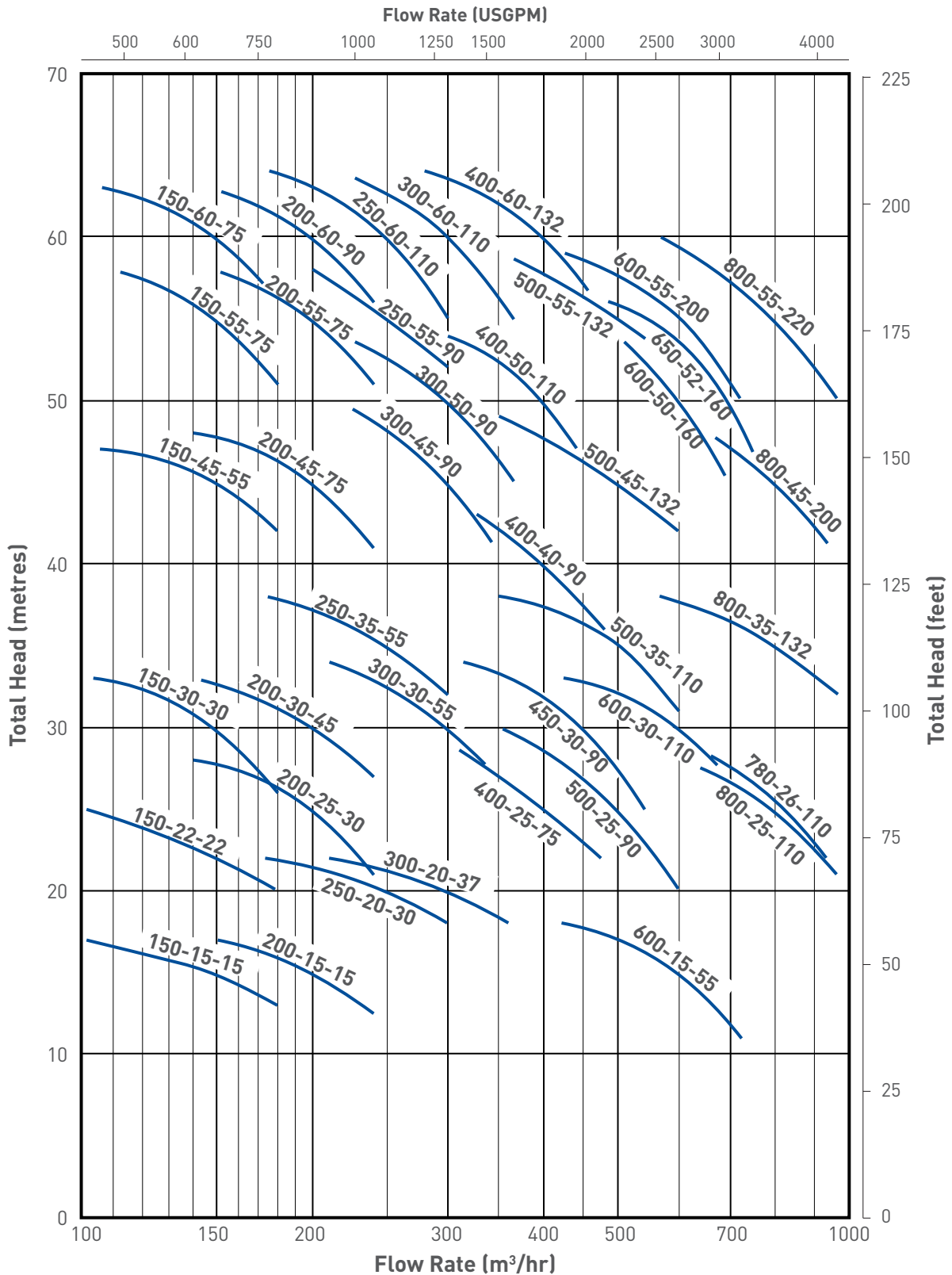

Performance curve is for clean, cold water only. Contact Pentair Southern Cross to discuss pump selections for specific applications.

PUMP PERFORMANCE SELECTION CHART (1000-2000m³/hr)

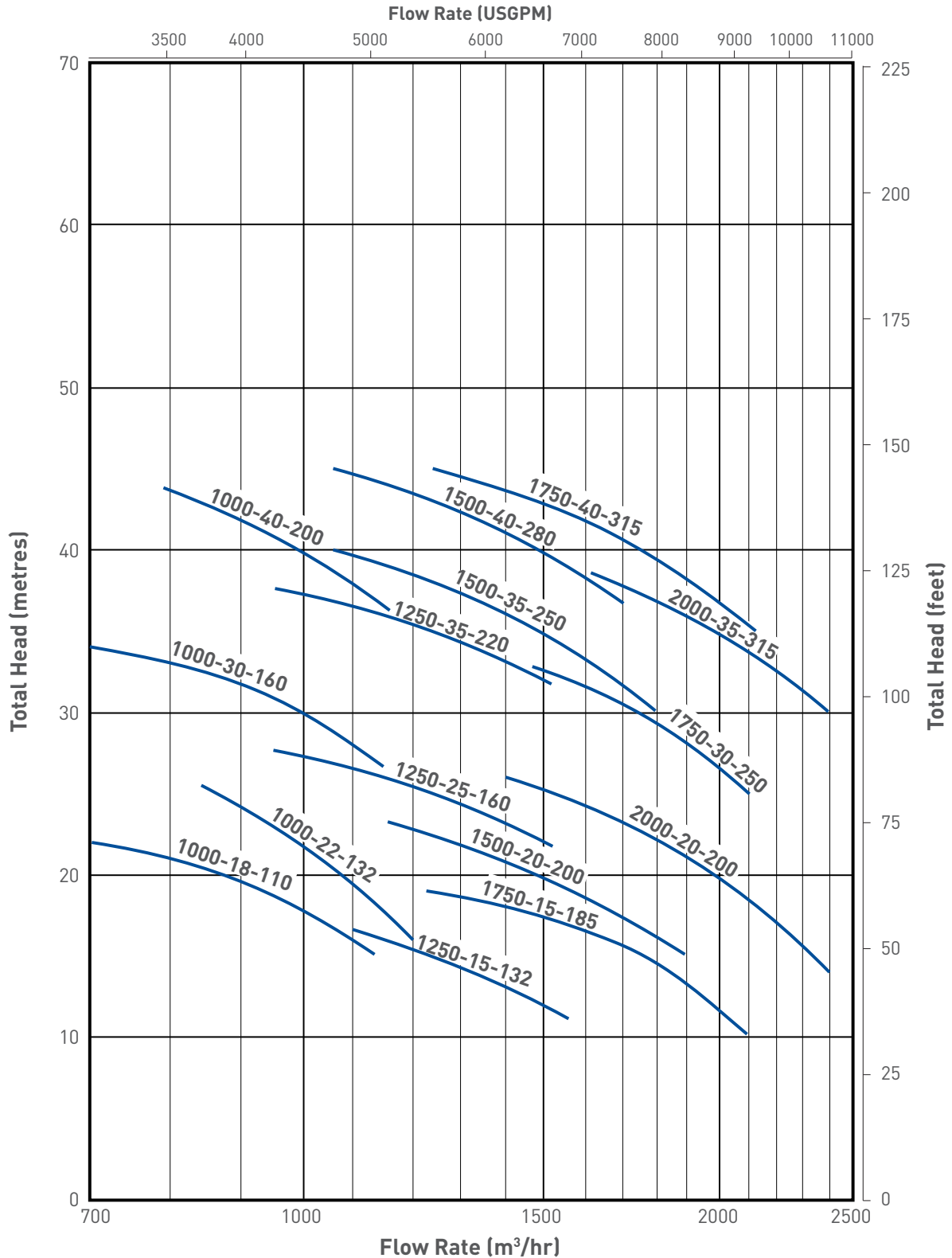

Performance curve is for clean, cold water only. Contact Pentair Southern Cross to discuss pump selections for specific applications.

SXSS

TECHNICAL DATA (CONTINUED)

Model	Outlet Dia. (inch)	Capacity (USGPM)	Head (ft)	Motor Power (hp)	Speed (r/min)	Efficiency (%)	Max. Dia. of Solids (inch)
SXSS30-30-7.5	3.15	106	100	10	1460	43	0.5
		132	97				
		158	93				
SXSS50-21-11	4	154	71	15	1460	48	0.8
		220	68				
		264	64				
SXSS100-18-11	4	308	64	15	1460	55	0.5
		440	58				
		528	48				
SXSS25-40-15	3.15	79	132	20	1460	35	0.8
		110	129				
		132	126				
SXSS50-35-15	4	154	122	20	1460	47	0.5
		220	113				
		264	103				
SXSS60-30-15	4	185	106	20	1460	50	0.5
		264	97				
		317	87				
SXSS75-25-15	4	229	90	20	1460	51	0.5
		330	80				
		396	71				
SXSS150-15-15	6	462	55	20	1460	56	0.5
		660	48				
		792	42				
SXSS50-26-22	3.15	154	93	15	1460	48	0.8
		220	84				
		264	77				
SXSS75-35-22	4	229	122	30	980	48	0.5
		330	113				
		396	103				
SXSS75-45-22	4	229	154	30	980	48	0.5
		330	145				
		396	135				
SXSS100-25-22	4	308	87	30	980	55	0.6
		440	80				
		528	71				
SXSS150-22-22	6	462	80	30	980	60	1.3
		660	71				
		792	64				
SXSS200-15-22	6	616	55	30	980	60	1.8
		880	48				
		1056	43				
SXSS100-35-30	4	308	122	40	980	50	0.8
		440	113				
		528	100				
SXSS150-30-30	6	462	106	40	980	50	0.8
		660	97				
		792	84				

SXSS

TECHNICAL DATA (CONTINUED)

Model	Outlet Dia. (inch)	Capacity (USGPM)	Head (ft)	Motor Power (hp)	Speed (r/min)	Efficiency (%)	Max. Dia. of Solids (inch)
SXSS200-25-30	6	616	90	40	980	51	1.0
		880	80				
		1056	68				
SXSS250-20-30	6	770	74	40	980	60	1.0
		1100	64				
		1320	58				
SXSS100-45-37	4	308	154	50	980	43	0.8
		440	145				
		528	135				
SXSS100-50-37	4	308	171	50	980	43	0.5
		440	161				
		528	151				
SXSS300-20-37	6	1056	71	50	980	58	1.1
		1320	64				
		1584	55				
SXSS100-60-45	4	308	206	60	980	43	0.5
		440	193				
		528	177				
SXSS200-30-45	6	616	106	60	980	53	1.0
		880	97				
		1056	87				
SXSS150-45-55	6	462	151	75	980	50	0.8
		660	145				
		792	135				
SXSS250-35-55	6	770	122	75	980	53	1.4
		1100	113				
		1320	106				
SXSS300-30-55	6	924	109	75	980	55	1.4
		1320	97				
		1584	84				
SXSS600-15-55	10	1848	58	75	980	62	1.3
		2640	48				
		3168	35				
SXSS150-55-75	6	462	187	100	980	48	0.6
		660	177				
		792	164				
SXSS150-60-75	6	462	203	100	980	48	0.6
		660	193				
		792	180				
SXSS200-45-75	6	616	154	100	980	52	0.8
		880	145				
		1056	132				
SXSS200-55-75	6	616	187	100	980	50	0.8
		880	177				
		1056	164				
SXSS350-35-75	8	1078	251	100	980	60	1.1
		1540	241				
		1848	228				

SXSS

TECHNICAL DATA (CONTINUED)

Model	Outlet Dia. (inch)	Capacity (USGPM)	Head (ft)	Motor Power (hp)	Speed (r/min)	Efficiency (%)	Max. Dia. of Solids (inch)
SXSS400-25-75	8	1232	93	100	980	62	1.1
		1760	80				
		2112	74				
SXSS200-60-90	6	616	203	125	980	50	0.6
		880	193				
		1056	183				
SXSS250-55-90	6	748	187	125	980	50	0.6
		1100	177				
		1320	167				
SXSS300-45-90	6	924	161	125	980	52	1.0
		1320	145				
		1584	126				
SXSS300-50-90	6	924	174	125	980	52	1.0
		1320	161				
		1584	145				
SXSS400-40-90	8	1232	142	125	980	53	1.0
		1760	129				
		2112	116				
SXSS500-25-90	8	1540	97	125	980	65	1.0
		2200	80				
		2640	64				
SXSS450-30-90	8	1386	109	125	980	64	1.0
		1980	97				
		2376	80				
SXSS250-60-110	6	770	206	150	980	54	0.8
		1100	193				
		1320	177				
SXSS300-60-110	6	924	206	150	980	55	0.8
		1320	193				
		1584	180				
SXSS400-50-110	8	1232	174	150	980	56	1.1
		1760	161				
		2112	145				
SXSS500-35-110	8	1540	122	150	980	61	1.3
		2200	113				
		2640	100				
SXSS600-30-110	10	1848	106	150	980	64	1.4
		2640	97				
		3168	84				
SXSS800-25-110	12	2464	90	150	980	66	2.0
		3520	80				
		4224	68				
SXSS1000-18-110	12	3080	71	150	980	68	2.0
		4400	58				
		5280	42				
SXSS780-26-110	12	2398	93	150	980	68	2.0
		3432	84				
		4114	71				

SXSS

TECHNICAL DATA (CONTINUED)

Model	Outlet Dia. (inch)	Capacity (USGPM)	Head (ft)	Motor Power (hp)	Speed (r/min)	Efficiency (%)	Max. Dia. of Solids (inch)
SXSS400-60-132	8	1232	206	175	980	68	1.1
		1760	193				
		2112	177				
SXSS500-45-132	8	1540	158	175	980	67	1.1
		2200	145				
		2640	135				
SXSS500-55-132	8	1540	190	175	980	70	1.1
		2200	177				
		2640	167				
SXSS800-35-132	12	2464	122	175	980	70	1.7
		3520	113				
		4224	103				
SXSS1000-22-132	12	3080	87	175	980	71	2.0
		4400	71				
		5280	55				
SXSS1250-15-132	12	3850	58	175	980	70	2.2
		5500	48				
		6600	39				
SXSS600-50-160	8	1848	180	215	980	65	1.1
		2640	161				
		3168	138				
SXSS650-52-160	8	2002	180	215	980	65	1.1
		2860	167				
		3432	142				
SXSS1250-25-160	14	3850	90	215	980	70	2.2
		5500	80				
		6600	71				
SXSS1000-30-160	12	3080	109	215	980	70	2.9
		4400	97				
		5280	80				
SXSS1750-15-185	14	5390	61	250	980	70	2.2
		7700	48				
		9240	32				
SXSS600-55-200	10	1848	190	265	980	62	1.1
		2640	177				
		3168	161				
SXSS800-45-200	12	2464	158	265	980	66	1.7
		3520	145				
		4224	129				
SXSS1000-40-200	12	3080	145	265	980	70	1.7
		4400	129				
		5280	113				
SXSS1500-20-200	14	4620	77	265	980	71	2.2
		6600	64				
		7920	48				
SXSS2000-20-200	16	6160	80	265	980	72	2.2
		8800	84				
		10560	45				

SXSS

TECHNICAL DATA (CONTINUED)

Model	Outlet Dia. (inch)	Capacity (USGPM)	Head (ft)	Motor Power (hp)	Speed (r/min)	Efficiency (%)	Max. Dia. of Solids (inch)
SXSS800-55-220	12	2464	193	300	980	66	1.5
		3520	177				
		4224	161				
SXSS1250-35-220	14	3850	126	300	980	70	1.8
		5500	113				
		6600	97				
SXSS1000-50-250	12	3080	177	330	980	68	1.8
		4400	161				
		5280	145				
SXSS1500-35-250	14	4620	129	330	980	72	2.0
		6600	113				
		7920	97				
SXSS1750-30-250	14	5390	109	330	980	70	2.2
		7700	97				
		9240	80				
SXSS1500-40-280	14	4620	145	375	980	70	2.0
		6600	129				
		7920	113				
SXSS1750-40-315	14	5390	145	420	980	70	2.2
		7700	129				
		9240	113				
SXSS2000-35-315	16	6160	129	420	980	72	2.4
		8800	113				
		10560	97				

SXSS

GENERAL ARRANGEMENT DRAWING

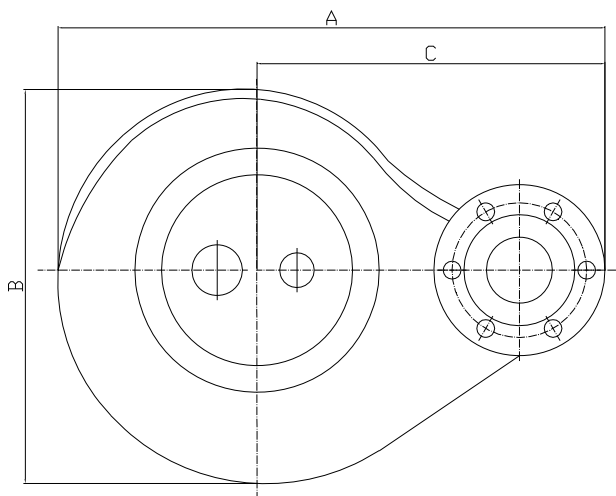
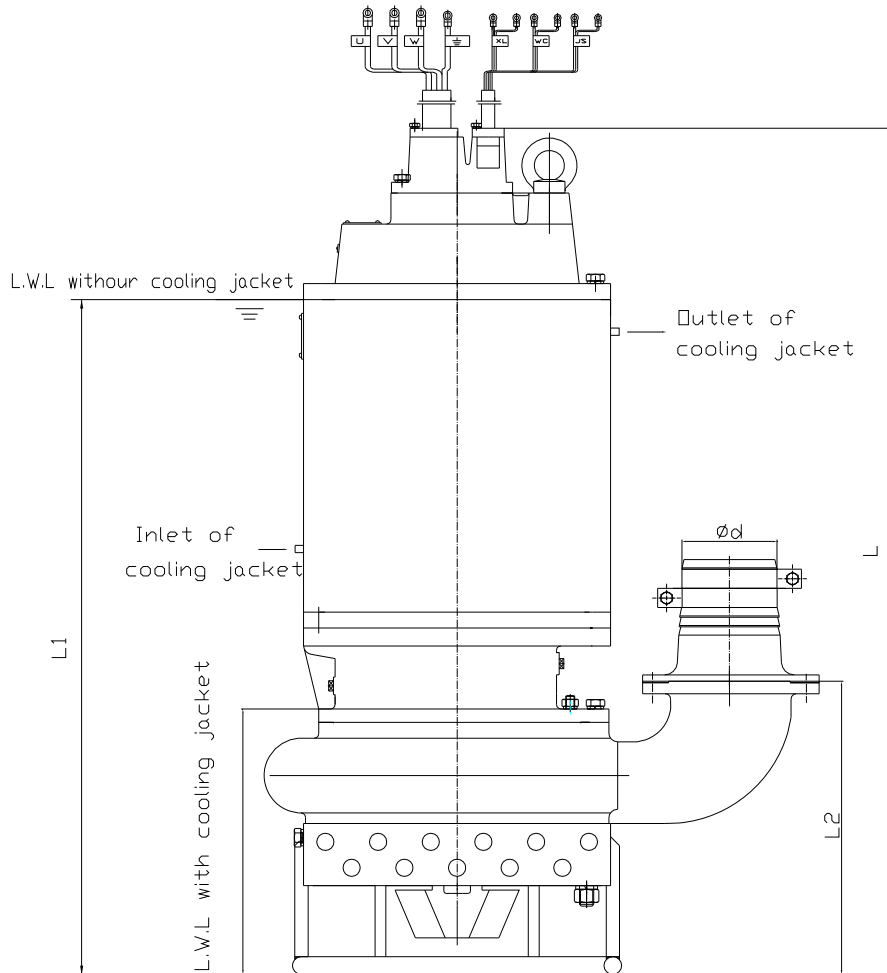

SXSS

DIMENSIONS

Model	Dimensions (inches)							Weight (pounds)
	L	L1	L2	A	B	C	d	
SXSS30-30-7.5	33.1	27.6	11.7	23.8	15.4	15.6	3.1	251
SXSS50-21-11	35.9	29.1	11.8	23.9	16.0	15.9	3.9	364
SXSS50-26-11	35.0	28.3	11.7	23.8	15.4	15.6	3.1	364
SXSS100-18-11	35.9	29.1	11.8	23.9	16.0	15.9	3.9	478
SXSS25-40-15	37.4	30.5	11.4	26.5	17.3	17.1	3.1	485
SXSS50-35-15	37.4	30.5	11.4	24.9	15.2	16.6	3.9	485
SXSS60-30-15	37.4	30.5	11.4	24.9	15.2	16.6	3.9	485
SXSS75-25-15	37.4	30.5	11.8	23.9	16.0	15.9	3.9	485
SXSS150-15-15	39.0	32.0	13.4	24.4	16.1	17.9	5.9	551
SXSS75-35-22	53.9	43.5	19.8	36.4	25.6	19.9	3.9	1279
SXSS75-45-22	53.9	43.5	19.8	36.4	25.6	19.9	3.9	1279
SXSS100-25-22	55.2	44.7	21.1	34.8	24.8	21.5	3.9	1279
SXSS150-22-22	55.2	44.7	21.1	34.8	24.8	22.4	5.9	1279
SXSS200-15-22	54.1	43.7	20.0	34.3	24.8	21.7	5.9	1279
SXSS100-35-30	57.2	45.0	16.7	32.8	24.8	23.8	3.9	1213
SXSS150-30-30	57.2	45.0	16.7	32.8	24.8	23.8	5.9	1213
SXSS200-25-30	57.5	45.2	18.5	32.9	24.8	23.8	5.9	1213
SXSS250-20-30	57.5	45.2	18.5	32.9	24.8	23.8	5.9	1213
SXSS100-45-37	61.4	46.1	19.1	37.4	25.6	25.2	3.9	1874
SXSS100-50-37	61.4	46.1	19.1	37.4	25.6	25.2	3.9	1874
SXSS300-20-37	61.7	46.1	20.1	42.1	23.4	30.5	5.9	1709
SXSS100-60-45	65.7	48.4	19.5	41.3	26.8	26.2	3.9	2205
SXSS200-30-45	66.9	49.4	19.5	39.6	26.2	25.6	5.9	2205
SXSS150-45-55	66.6	49.1	19.2	39.8	26.7	25.2	5.9	2514
SXSS250-35-55	66.9	49.4	19.5	39.6	26.2	25.6	5.9	2514
SXSS300-30-55	66.9	49.4	19.5	39.6	26.2	25.6	5.9	2514
SXSS600-15-55	67.7	50.2	20.3	41.4	28.0	26.6	9.8	2514
SXSS150-55-75	72.2	54.3	19.0	43.9	31.5	28.1	5.9	3396
SXSS150-60-75	72.2	54.3	19.0	43.9	31.5	28.1	5.9	3396
SXSS200-45-75	75.0	56.1	19.2	39.8	26.7	25.2	5.9	3396
SXSS200-55-75	72.2	54.3	19.0	43.9	31.5	28.1	5.9	3396
SXSS350-35-75	74.1	55.3	19.1	52.4	27.2	37.3	7.9	3396
SXSS400-25-75	74.3	55.5	19.1	56.0	26.2	41.2	7.9	3396
SXSS200-60-90	72.2	54.3	19.0	43.9	31.5	28.1	5.9	3418
SXSS200-55-90	72.2	54.3	19.0	43.9	31.5	28.1	5.9	3418
SXSS300-45-90	74.1	54.3	19.0	43.9	31.5	28.1	5.9	3418
SXSS300-50-90	75.7	55.9	19.3	60.6	33.4	43.7	5.9	3418
SXSS400-40-90	76.4	56.3	19.7	62.2	33.5	45.3	7.9	3418
SXSS500-25-90	74.3	55.5	19.1	56.0	26.2	41.2	7.9	3418
SXSS450-30-90	74.3	55.5	19.1	56.0	26.2	41.2	7.9	3418
SXSS250-60-110	86.7	60.1	19.1	43.9	31.5	28.1	5.9	4344
SXSS300-60-110	86.7	60.1	19.1	43.9	31.5	28.1	5.9	4344

SXSS

DIMENSIONS (CONTINUED)

Model	Dimensions (inch)							Weight (pounds)
	L	L1	L2	A	B	C	d	
SXSS400-50-110	87.6	61.0	19.7	46.9	29.9	31.1	7.9	4344
SXSS500-35-110	88.4	61.8	20.5	46.5	29.5	40.2	7.9	4344
SXSS600-30-110	88.4	61.8	20.5	46.5	29.5	40.2	9.8	4344
SXSS800-25-110	94.8	67.9	24.6	64.6	33.6	47.5	11.8	4344
SXSS1000-18-110	94.8	67.9	24.6	64.6	33.6	47.5	11.8	4344
SXSS780-26-110	94.8	67.9	24.6	64.6	33.6	47.5	11.8	4344
SXSS400-60-132	91.7	65.6	20.5	60.6	33.4	44.0	7.9	4410
SXSS500-45-132	91.3	65.2	18.6	44.3	32.4	29.1	7.9	4410
SXSS500-55-132	91.3	65.2	18.6	44.3	32.4	29.1	7.9	4410
SXSS800-35-132	99.9	70.2	23.7	62.2	31.6	46.3	11.8	4410
SXSS1000-22-132	97.0	70.9	24.6	64.6	33.6	47.5	11.8	4410
SXSS1250-15-132	99.9	70.2	23.7	62.2	31.6	46.3	11.8	4410
SXSS600-50-160	105.2	69.8	18.6	44.3	32.4	29.1	7.9	5843
SXSS650-52-160	105.2	69.8	18.6	44.3	32.4	29.1	7.9	5843
SXSS1250-25-160	113.8	78.3	26.5	63.0	32.3	46.5	13.8	5843
SXSS1000-30-160	113.8	84.1	23.7	62.2	31.6	46.3	11.8	5843
SXSS1750-15-185	114.2	84.3	25.7	65.4	32.3	49.6	13.8	7718
SXSS600-55-200	105.2	69.8	18.6	44.9	32.4	29.1	9.8	7497
SXSS800-45-200	115.5	78.5	28.0	66.4	35.4	48.4	11.8	7497
SXSS1000-40-200	115.5	78.5	28.0	66.4	35.4	48.4	11.8	7718
SXSS1500-20-200	120.5	80.7	26.5	69.7	34.3	72.8	13.8	7718
SXSS2000-20-200	120.5	80.7	26.5	74.0	34.3	74.6	15.7	7718
SXSS800-55-220	115.5	78.5	28.0	66.4	35.4	48.4	11.8	7497
SXSS1250-35-220	115.0	79.6	28.7	84.6	38.5	64.2	13.8	7497
SXSS1000-50-250	117.3	81.9	28.0	88.6	38.5	68.1	11.8	7718
SXSS1500-35-250	118.6	83.1	28.7	84.6	38.5	64.2	13.8	7718
SXSS1750-30-250	118.6	83.1	28.7	84.6	38.5	64.2	13.8	7718
SXSS1500-40-280	120.4	85.0	28.0	88.6	38.5	68.1	13.8	7938
SXSS1750-40-315	127.4	89.0	31.7	85.8	40.4	65.0	13.8	8159
SXSS2000-35-315	127.4	89.0	31.7	89.0	40.4	68.1	15.7	8159

SECTIONAL DRAWING

MATERIALS OF CONSTRUCTION

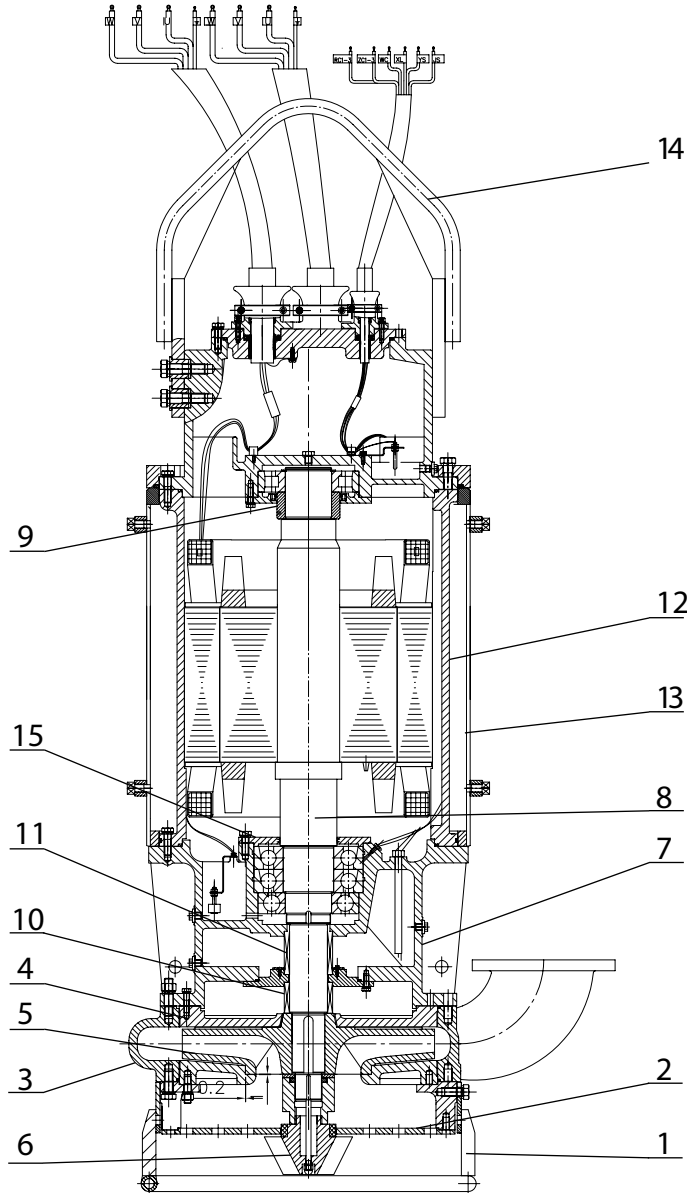

No.	Description	Standard Material	Material Options
1	Support Frame	Mild Steel	
2	Strainer	420 Stainless Steel	
3	Pump Casing	27% Chrome White Iron	316 Stainless Steel / Duplex ¹
4	Back Plate	27% Chrome White Iron	316 Stainless Steel / Duplex ¹
5	Impeller	27% Chrome White Iron	316 Stainless Steel / Duplex ¹
6	Agitator	27% Chrome White Iron	316 Stainless Steel / Duplex ¹
7	Oil Chamber Housing	Cast Iron	
8	Shaft	420 Stainless Steel	
9	Shaft Sleeve	420 Stainless Steel	
10	Wet End Mechanical Seal	304 Stainless Steel	
11	Motor Mechanical Seal	304 Stainless Steel	
12	Motor Casing	Cast Iron	
13	Motor Cooling Jacket	Fabricated Mild Steel	
14	Lifting Brace	Mild Steel	
15	Bearing Covers	Cast Iron	
16	Oil Chamber Cover	Cast Iron	



PENTAIR SOUTHERN CROSS

8618 Warrego Highway, Withcott, QLD 4352, Australia www.southerncross.pentair.com

All Pentair trademarks and logos are owned by Pentair, Ltd. All other brand or product names are trademarks or registered marks of their respective owners. Because we are continuously improving our products and services, Pentair reserves the right to change specifications without prior notice. Pentair is an equal opportunity employer.

A.B.N. 83 000 922 690 © 2012 Pentair, Ltd. All Rights Reserved.

© 2013 Pentair Southern Cross