

ISOspec DAVEY®

CF Series Bareshaft Pumps
CM Series Motor Pumps

ISO2858 Heavy Duty Industrial Centrifugal Pumps

DEPEND ON

DAVEY

PUMPS

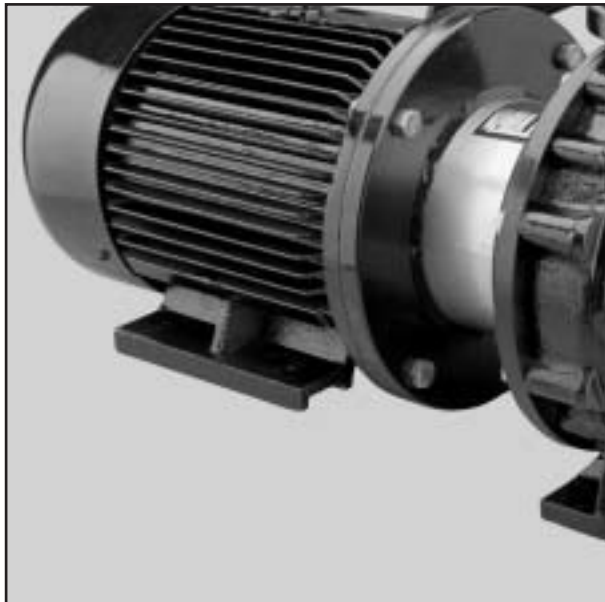
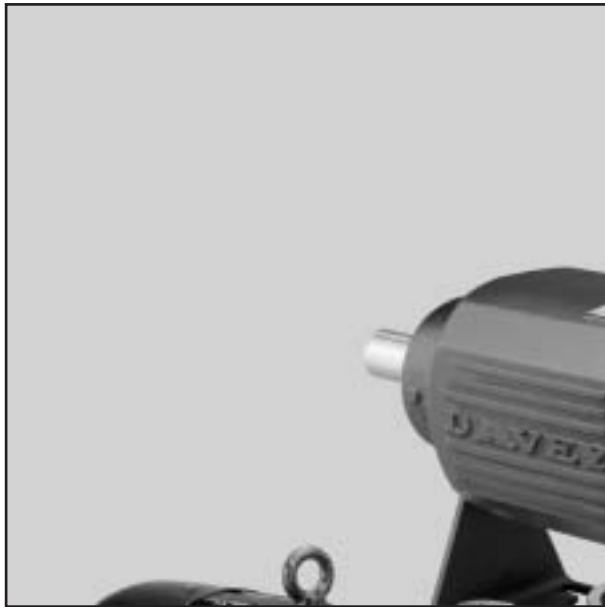

TECHNICAL SPECIFICATIONS

The Davey ISOspec® range has been designed to international standard **ISO2858** ensuring a sturdy & reliable, long lasting, high performing product that consumers have come to depend on from Davey.

Suitable Applications

Water Supply

Commercial irrigation, booster stations, municipal water supply, flood irrigation, general transfer.

Industry

Cooling tower transfer, refrigeration systems, commercial fountains, condensate recovery, dairy wash down packages.

Environmental

Dust suppression in mining & quarry applications, fume scrubbers for odour control, water treatment transfer & filtration.

Leisure

Water circulation in large aquatic centres, backwash filtration in commercial pools, water features & commercial fountains.

Building Services

Commercial heating, air conditioning systems, pressure boosting, cooling tower & fire service applications.

Pumped Liquids

Non aggressive & non combustible liquids. Clean low viscous liquids free of fibres or particles.

Operating Conditions

CF Series Bareshaft Pumps

Maximum flow	900m ³ /hr
Maximum total heads	160m
Liquid temperature*	-15 to 140°C
Operating pressure	16 Bar

* With optional high temperature seal.

CM Series Motor Pumps

Maximum flow	410m ³ /hr
Maximum total heads	160m
Liquid temperature*	-15 to 140°C
Operating pressure	16 Bar

* With optional high temperature seal.

Model Designation (Examples)

ISO CF 250x200-400

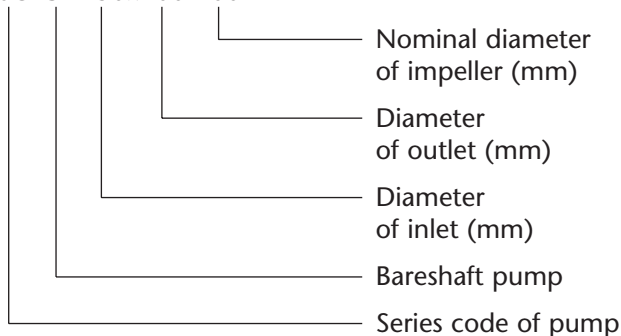

ISO CM 125x100-200

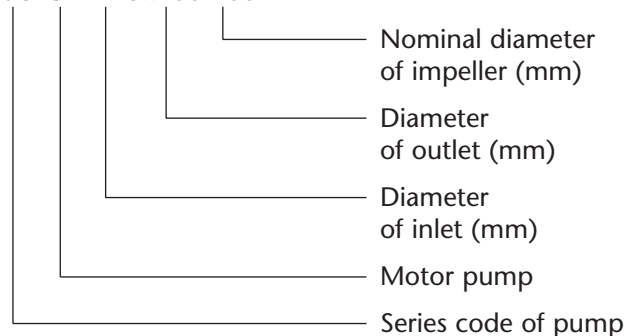

The Davey ISOspec® Series is comprised of 29 standard sizes. Pumps with different impeller diameters and speeds are available to satisfy various performance ranges. Performance curves within this catalogue are in compliance with ISO2858 standards.

TECHNICAL SPECIFICATIONS

Design Features

Davey ISOspec® design is in accordance with international standards of **ISO2858**, which means ISOspec® Series pumps are interchangeable with other similar pumps, conforming to the same standards. This ensures a robust, long lasting, high performing product consumers have come to depend on from Davey.

Bronze wear rings - fitted as standard, replaceable front & rear wear rings with optional materials, for a trouble-free lifecycle.

Bronze impeller - in a closed design is fitted as standard to prevent corrosion in stationary or inactive situations. Cast 304SS or 316SS are available on request. The use of 3-D solid model (CAD) Computer Aided Design and (CFD) Computational Fluid Dynamics ensures **high efficiencies**, reducing overall running costs. Impeller diameters can be trimmed to suit specified performance. ISOspec® impellers are dynamically balanced, providing smooth, vibration free operation, preventing premature bearing failure.

Pump casing - highly efficient cast iron volute casings, with flanges rated to PN1.6MPa (16bar), drilled to AS2129, Table E. Material options: 304SS or 316SS.

Casing o-ring - re-usable o-rings in Nitrile for ease of re-assembly (optional materials available).

Shaft seal - single, high quality John Crane or approved equivalent mechanical seal with **carbon vs ceramic** fitted as standard to all ISOspec® Series pumps with other options such as Silicone vs Silicone or high temp also available.

Tappings - convenient suction & discharge pressure gauge tappings plus volute drain, fitted as standard to all ISOspec® Series pumps.

Back pull-out design - allowing for easy removal of rotating element without disturbing the pipework, lagging or pump volute casing. This is proven to reduce downtime whilst performing routine maintenance.

CM Series adaptor housing - heavy duty, flanged to IEC accepting AS 1359 standard designed motors.

Enlarged shaft - reduces shaft deflection. Standard in 420SS & 316SS as an option. Tapered & keyed shaft design allowing ease of removal in maintenance & positive locking whilst in operation (CF Series only).

Stub shaft - standard in 316SS, attached via a heavy duty muff coupling assembly. Tapered & keyed shaft design allowing ease of removal in maintenance & positive locking whilst in operation (CM Series only).

Bearings - Heavy duty SKF or approved equivalent, greased for life, reducing maintenance. Protected by a quality manufactured lip seal reducing ingress of moisture or foreign matter. Housed within removable bearing cap cover assembly (CF Series only).

CF Series bearing housing - Robust / heavy duty, manufactured in high strength cast iron providing trouble-free life cycle.

CM Series Motors - All motors are MEPS compliant ensuring minimum efficiency requirements to AS/NZS 1359.5.2000. IP55, TEFC (totally enclosed fan cooled), insulation class F, temperature rise class B, 415V, 50Hz. Other voltages available upon request.

TECHNICAL SPECIFICATIONS

ISO **DAVEY**
spec

CF Series Arrangement

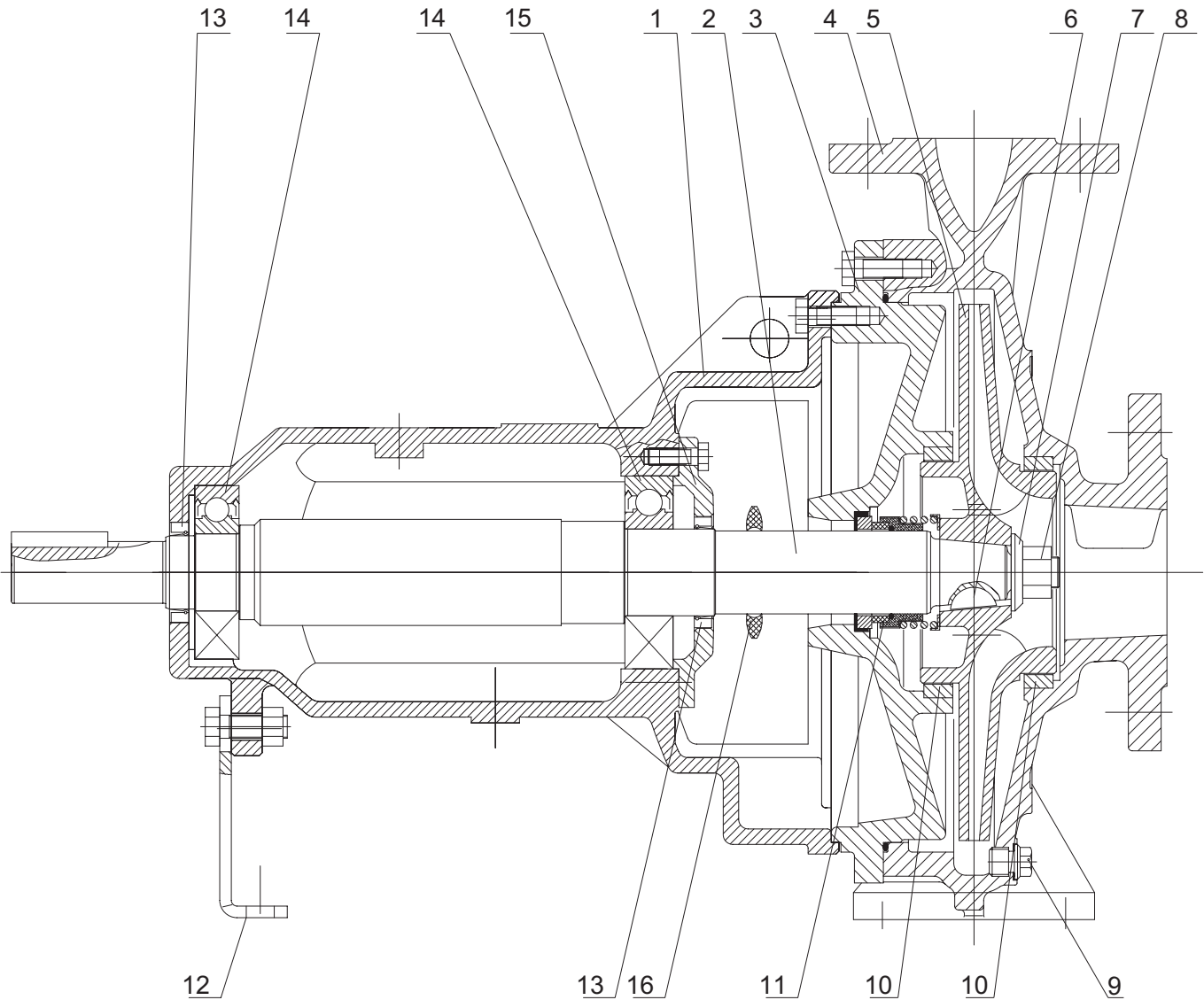

- | | | |
|----------------------|---------------------------|--------------------------|
| 1. Bearing housing | 2. Shaft | 3. Rear casing cover |
| 4. Pump casing | 5. Impeller | 6. Impeller key |
| 7. Impeller washer | 8. Impeller nut | 9. Volute drain plug |
| 10. Bronze wear ring | 11. Mechanical shaft seal | 12. Bearing housing foot |
| 13. Bearing lip seal | 14. Bearing | 15. Bearing cap |
| 16. Water slinger | | |

TECHNICAL SPECIFICATIONS

ISO DAVEY
spec

CM Series Arrangement

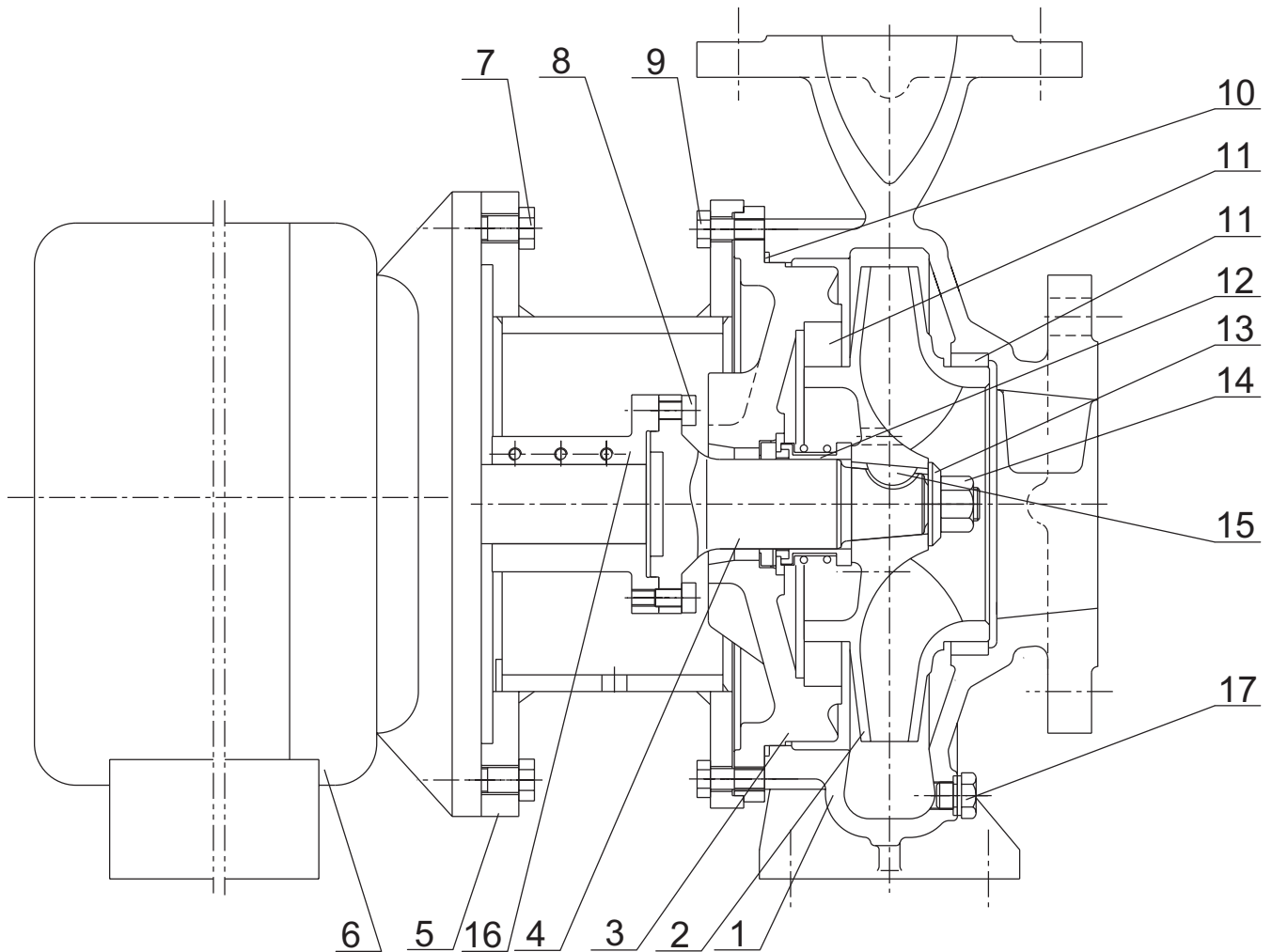

- | | | |
|---------------------|-----------------------|---------------------------|
| 1. Pump Casing | 2. Impeller | 3. Rear Casing Cover |
| 4. Stub Shaft | 5. Bell Housing | 6. Motor |
| 7. Bolt | 8. Bolt | 9. Bolt |
| 10. O-ring | 11. Bronze Wear Ring | 12. Mechanical Shaft Seal |
| 13. Impeller Washer | 14. Impeller Nut | 15. Impeller Key |
| 16. Muff Coupling | 17. Volute Drain Plug | |

TECHNICAL SPECIFICATIONS

ISO **DAVEY**
spec

CF Series Performance Range

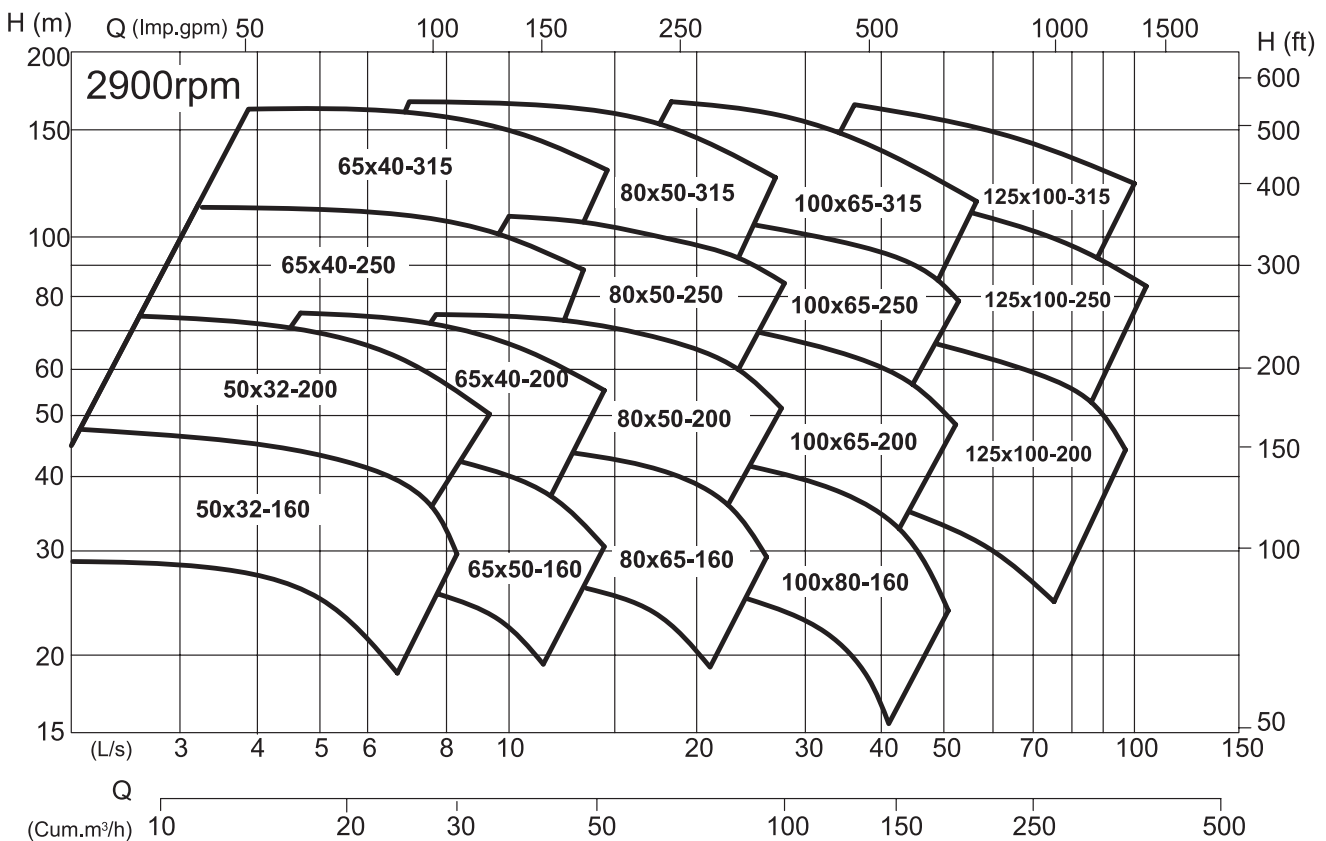
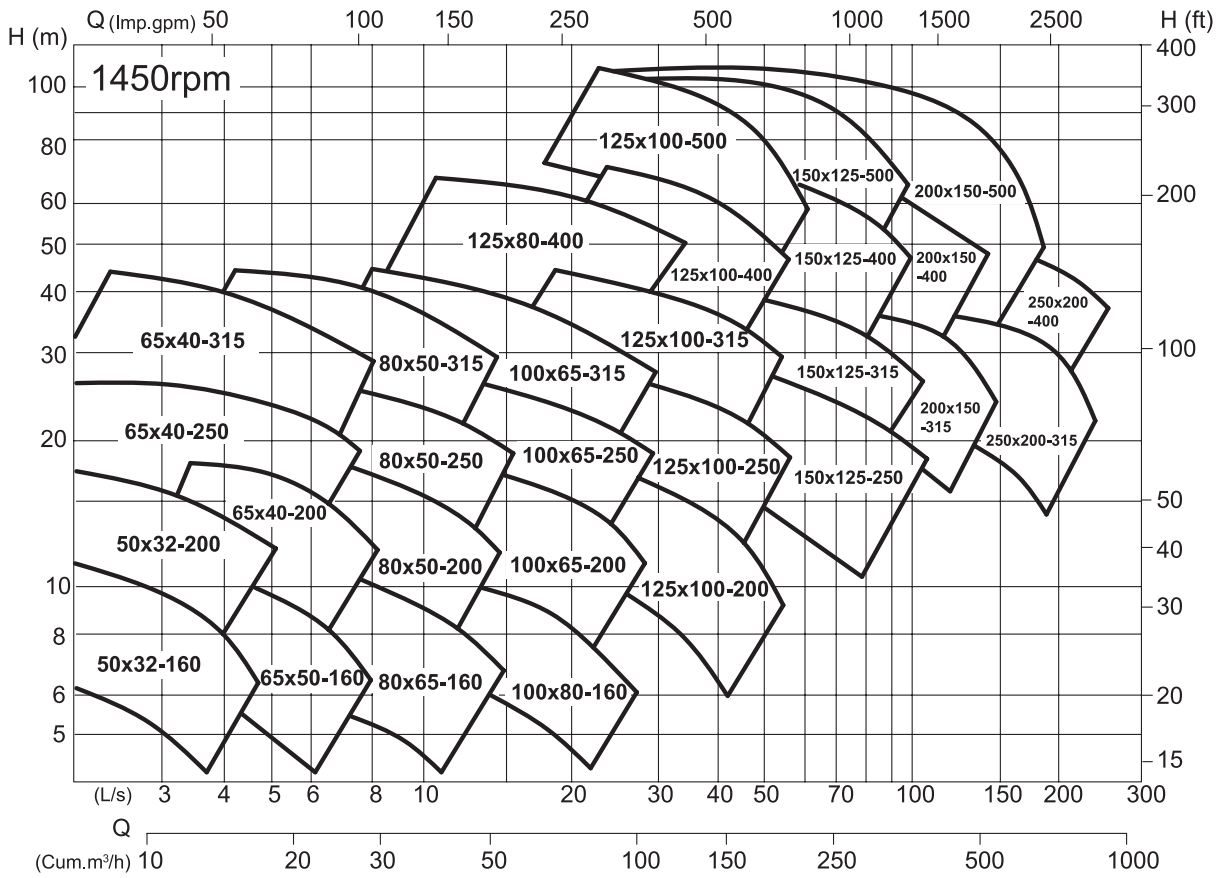

TECHNICAL SPECIFICATIONS



CM Series Performance Range

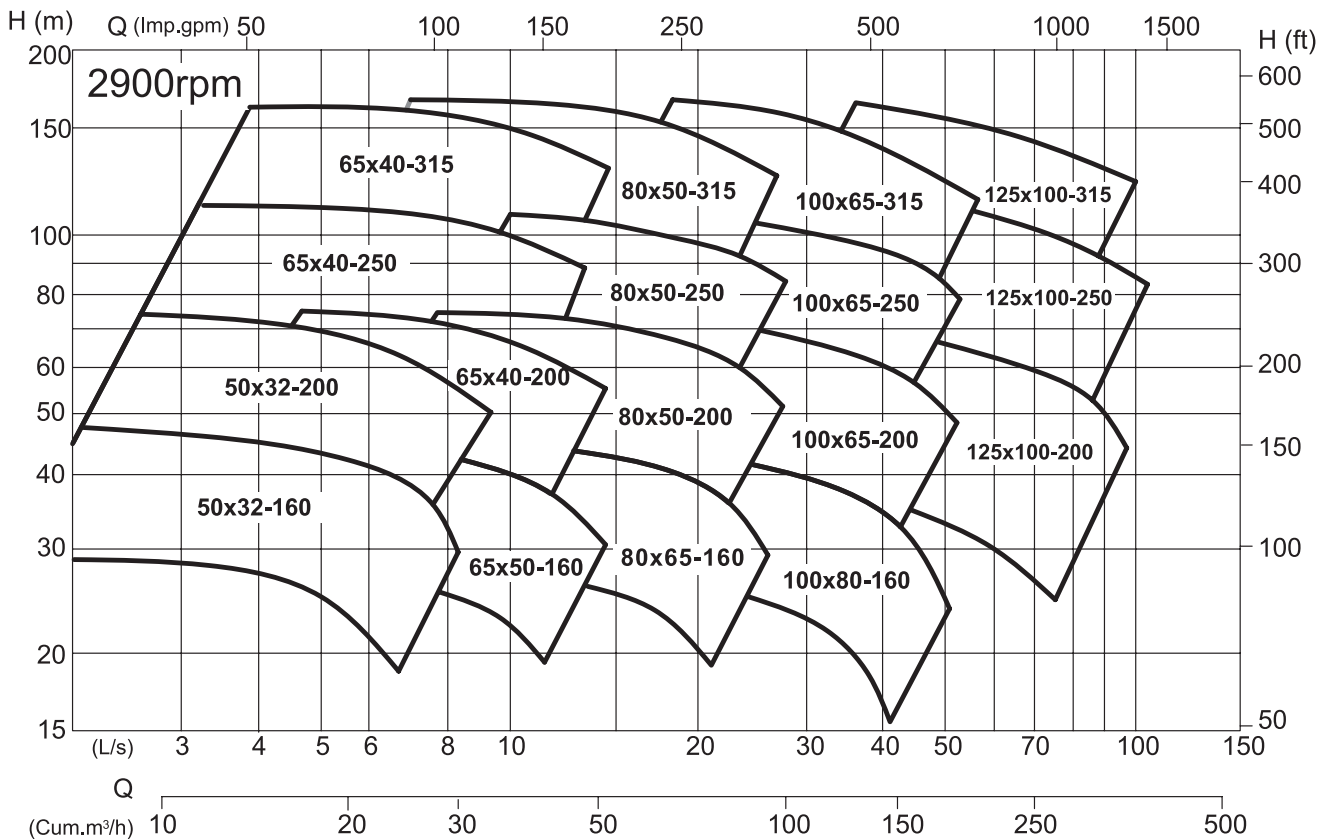
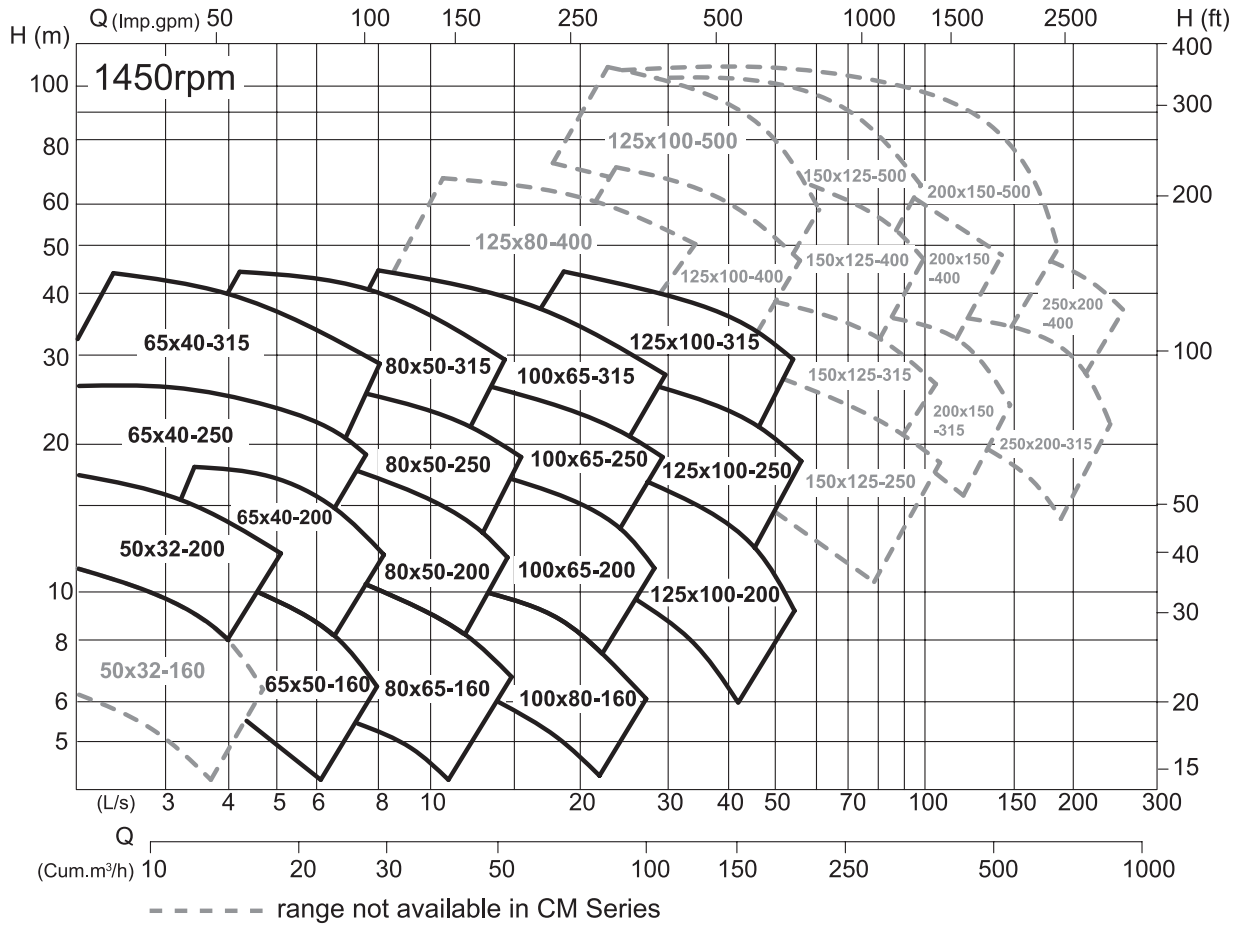

TECHNICAL SPECIFICATIONS

ISOspec[®]

CF & CM Series Performance Curve 50x32-160

CM not available in 4 Pole, 1450rpm

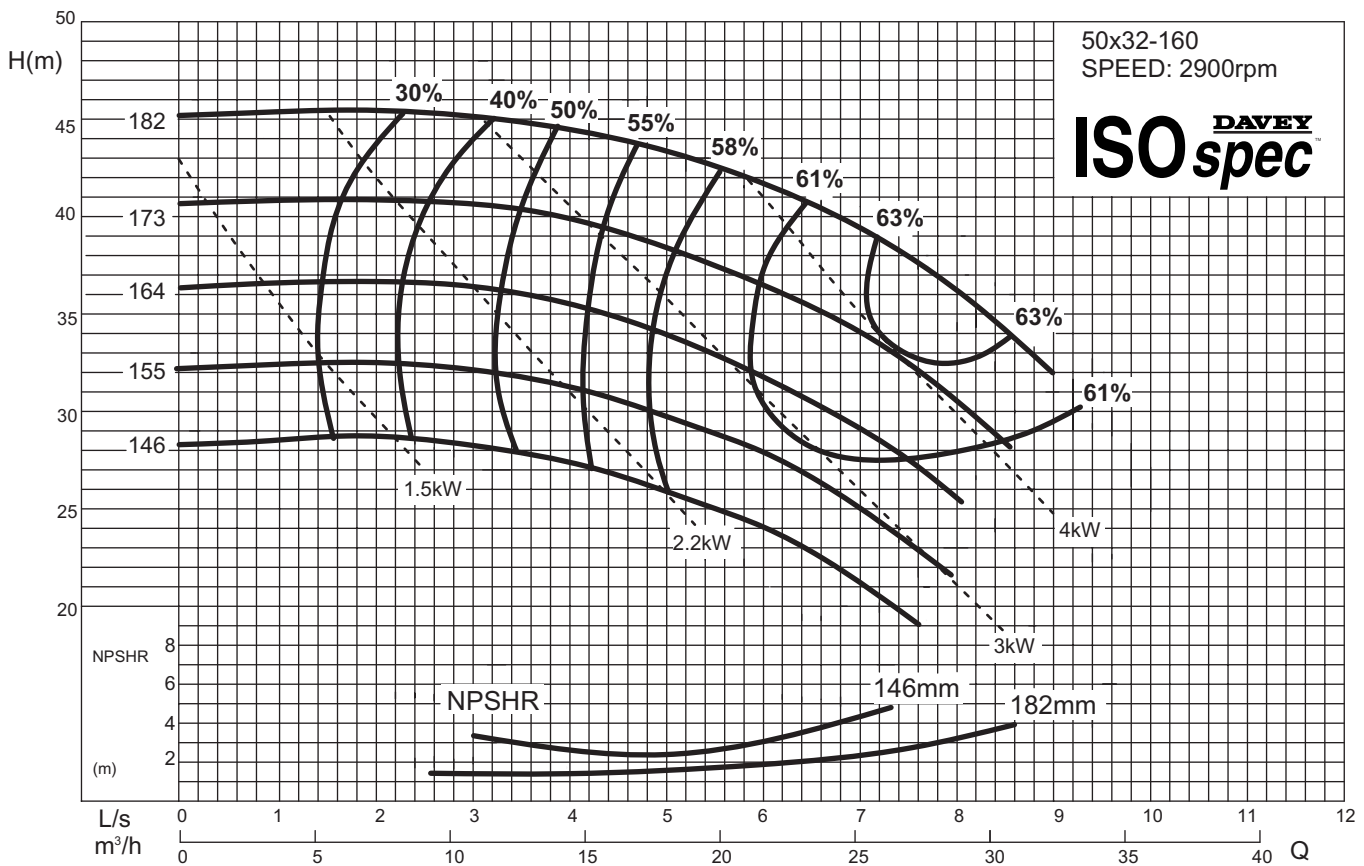
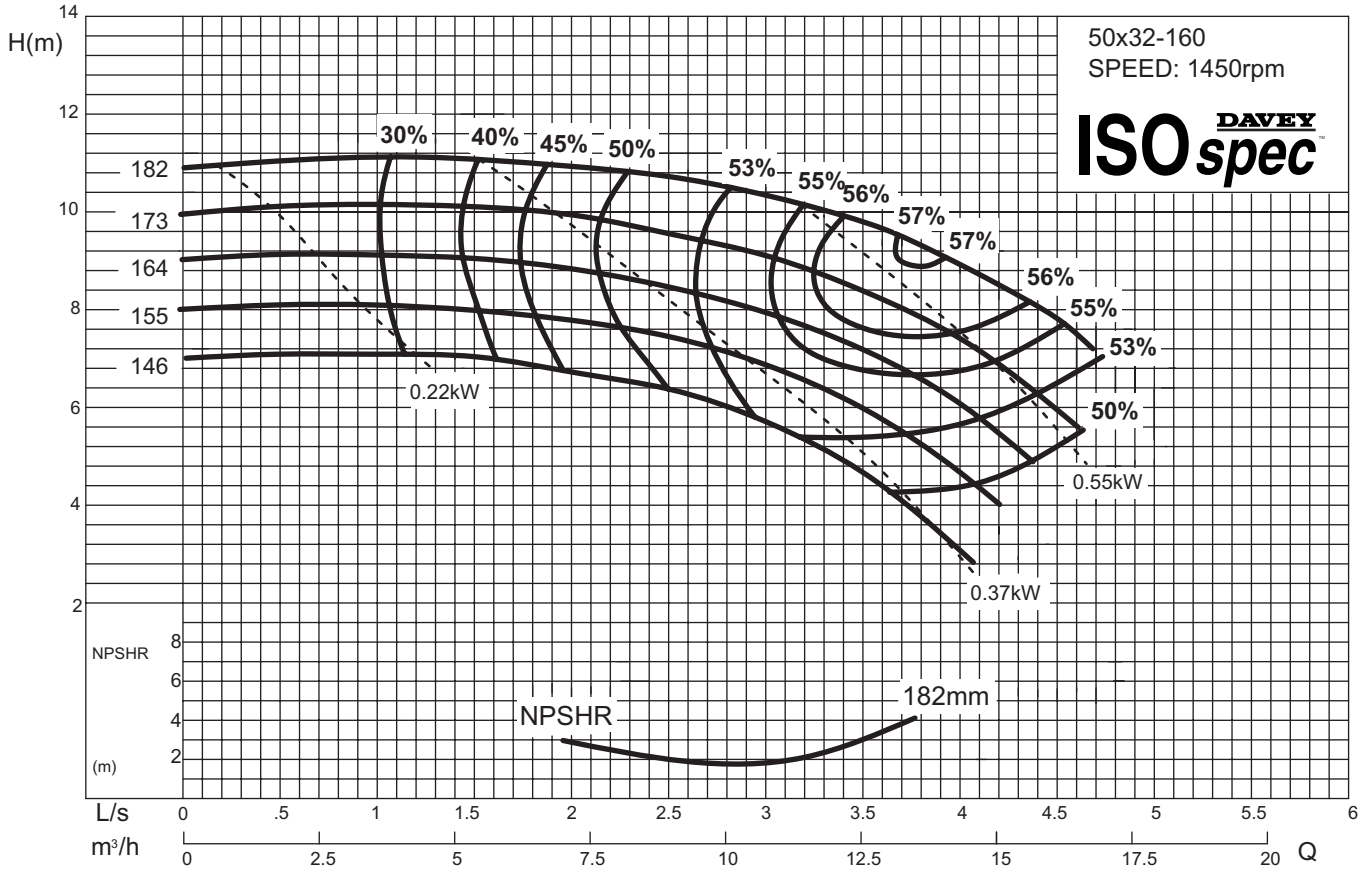

TECHNICAL SPECIFICATIONS



CF & CM Series Performance Curve 50x32-200

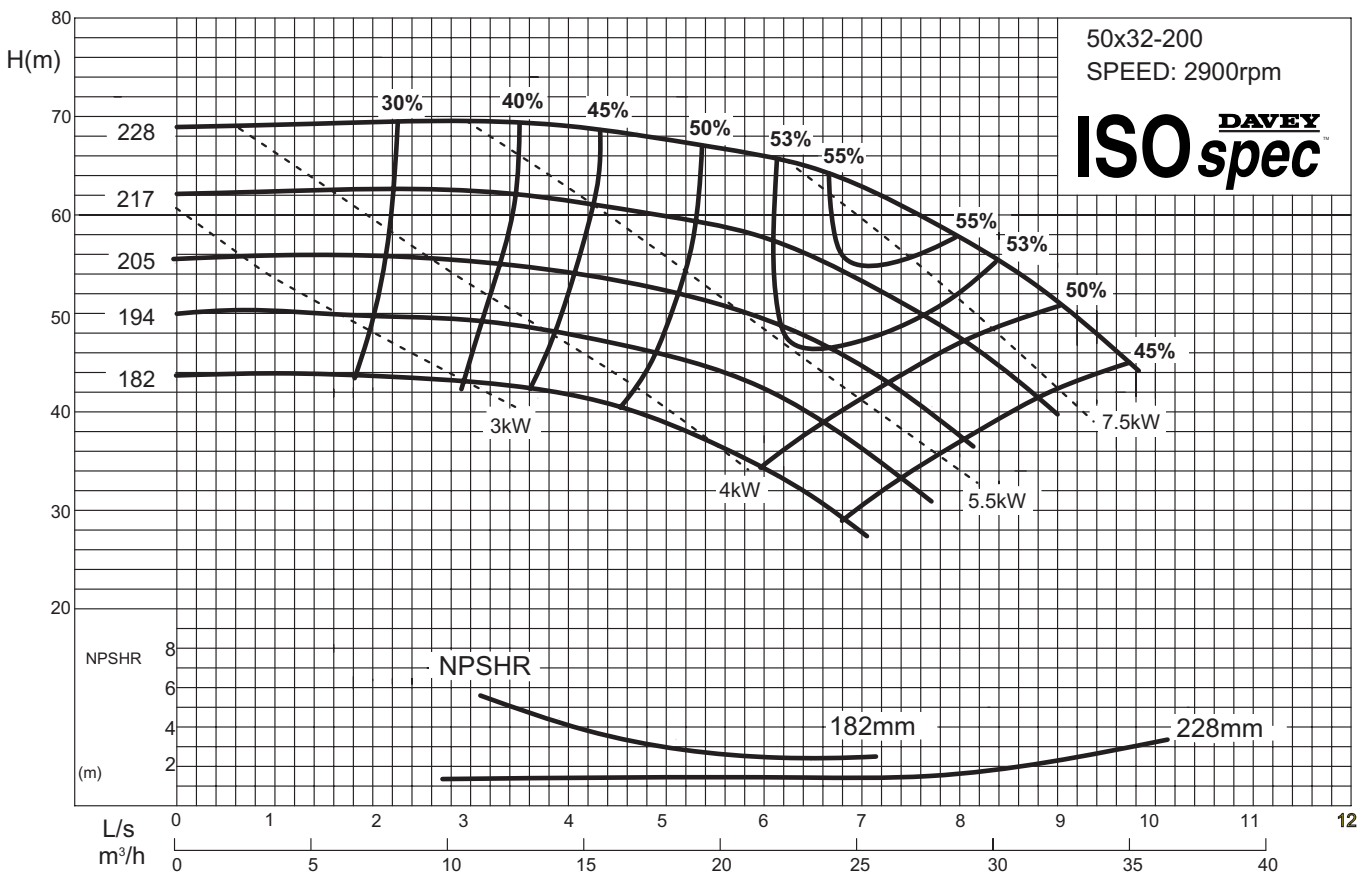
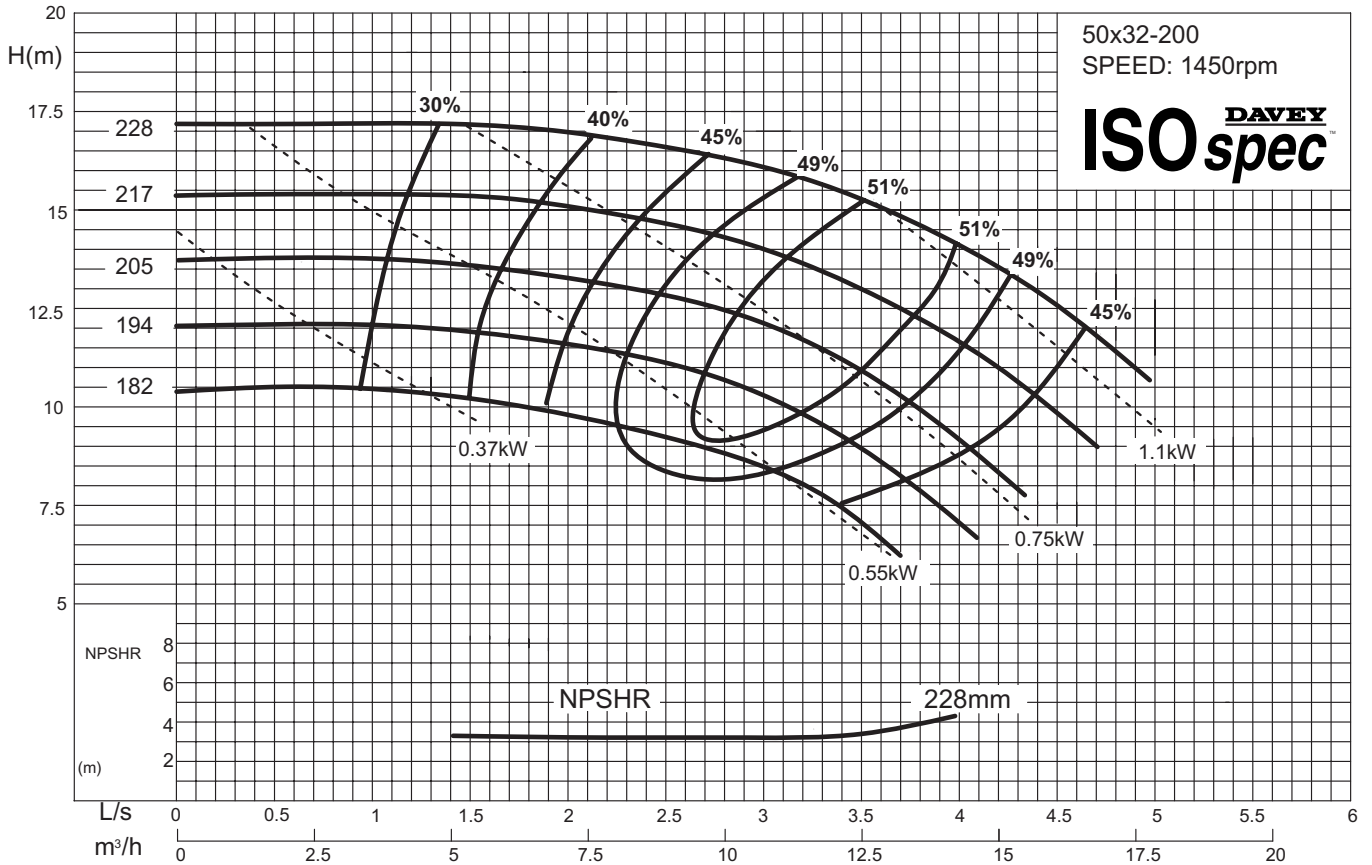

TECHNICAL SPECIFICATIONS



CF & CM Series Performance Curve 65x50-160

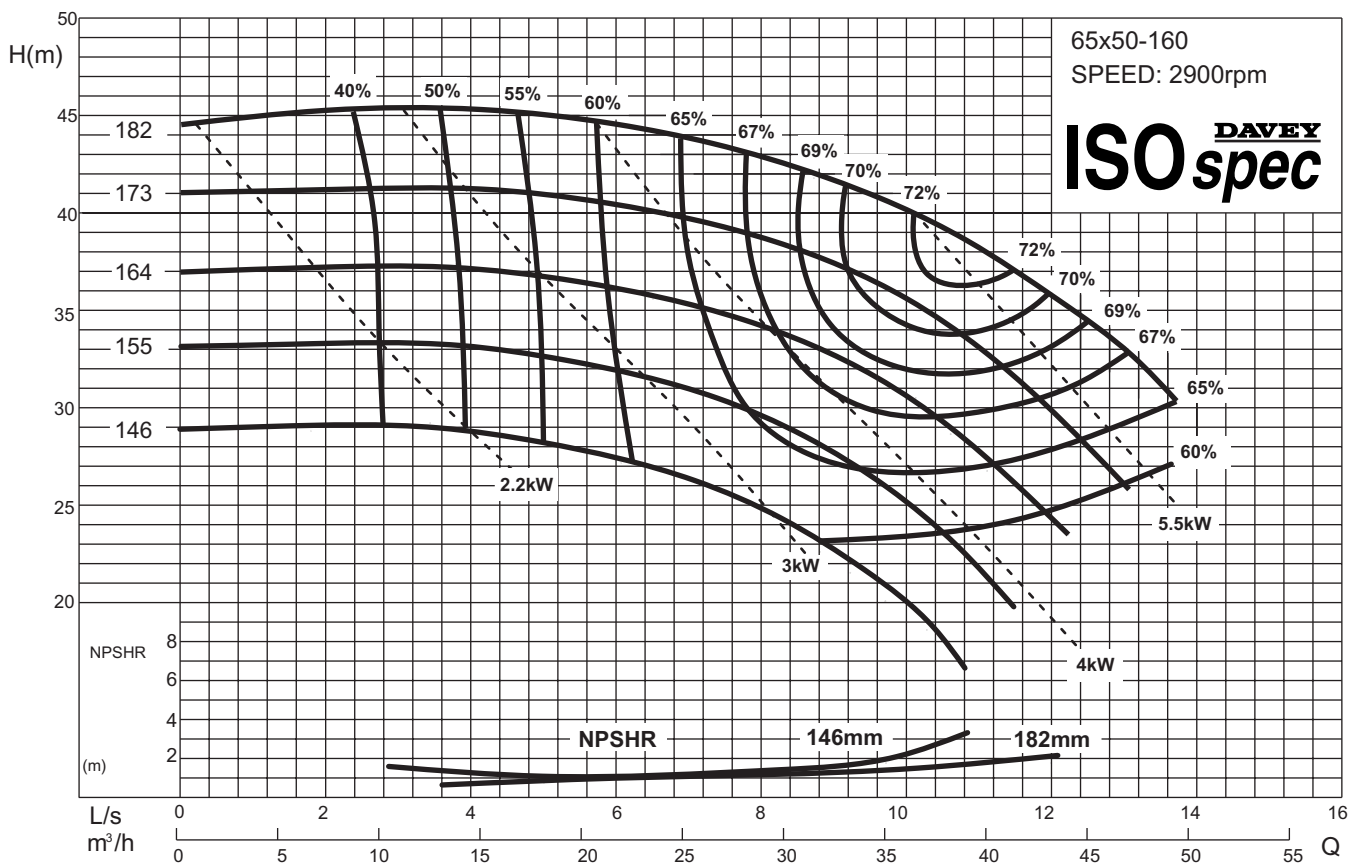
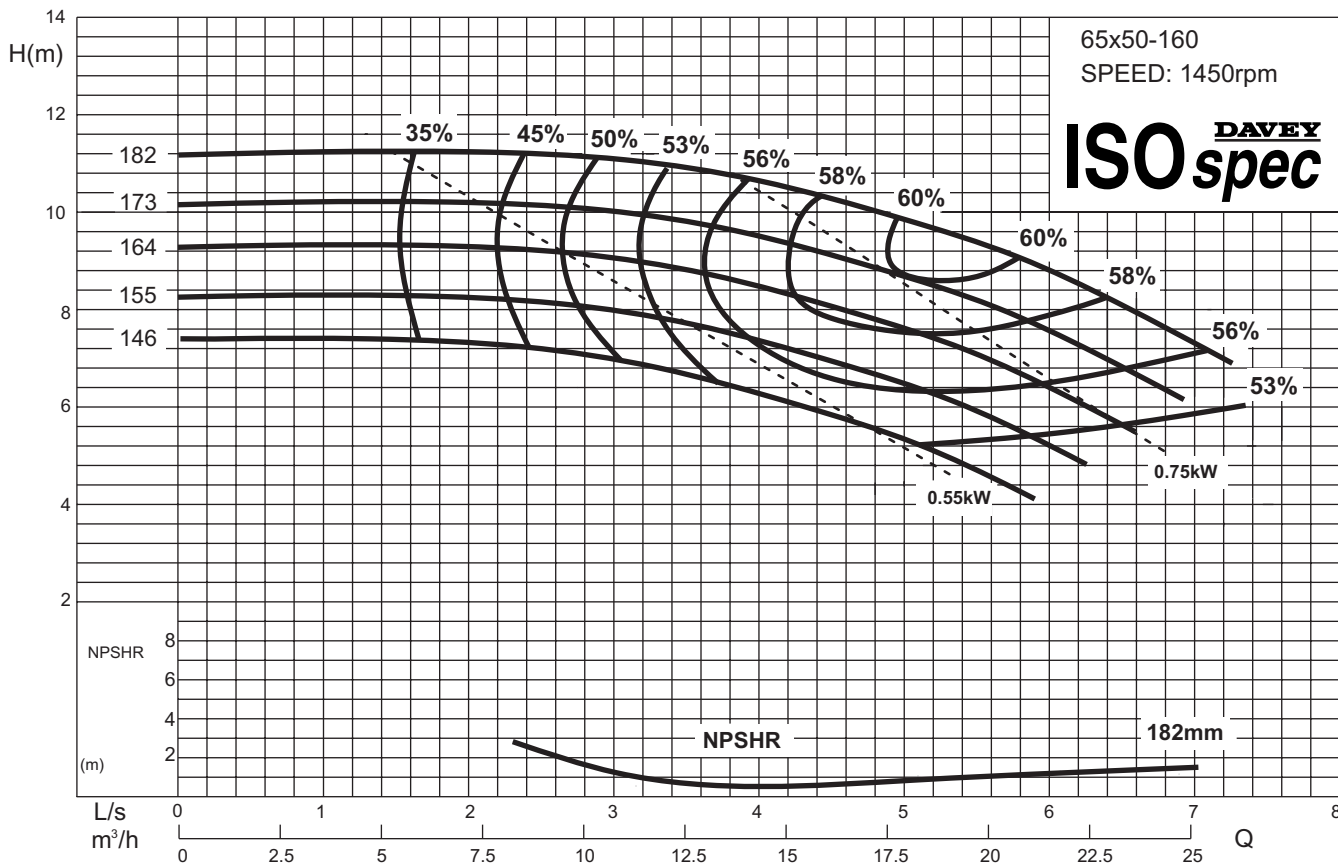

TECHNICAL SPECIFICATIONS



CF & CM Series Performance Curve 65x40-200

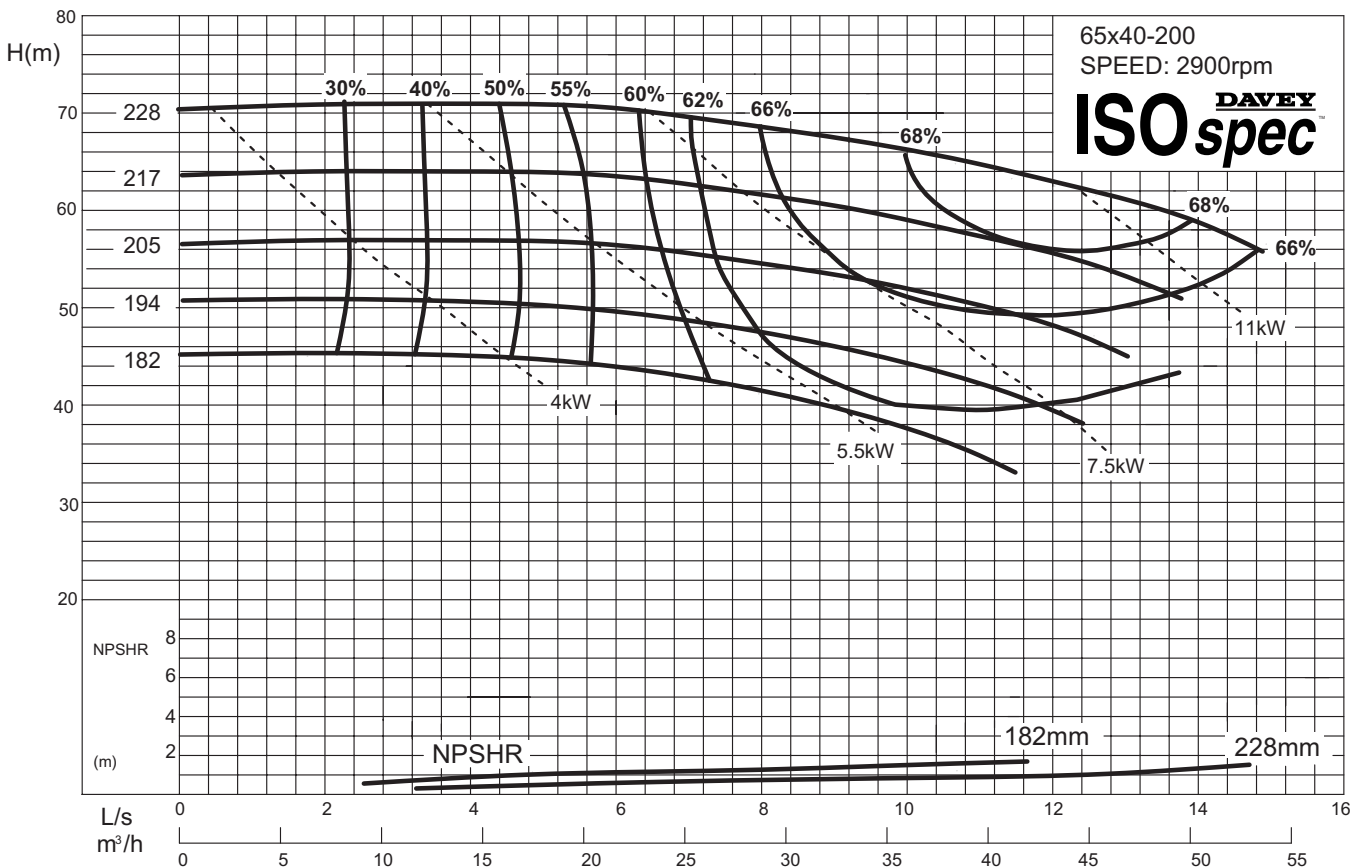
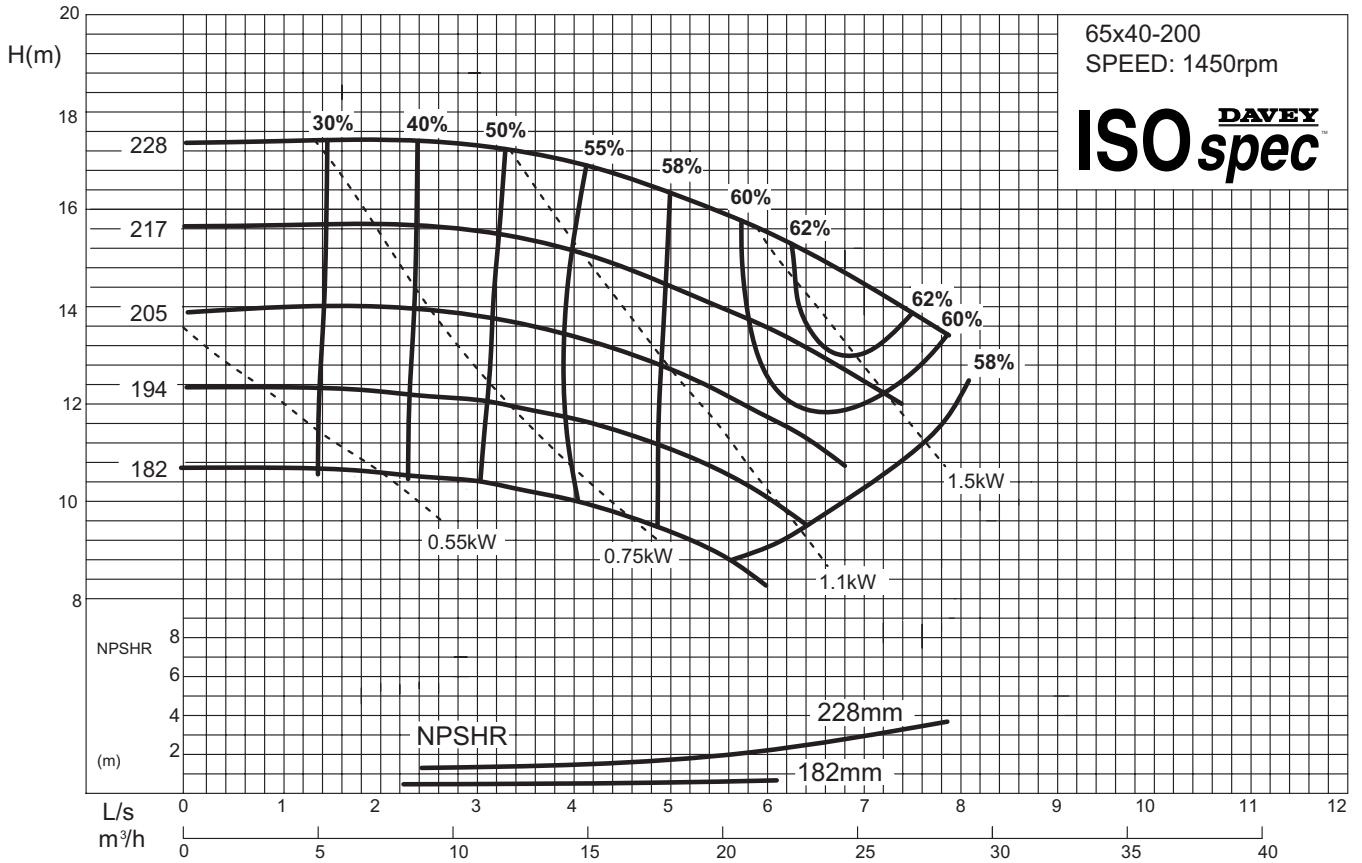

TECHNICAL SPECIFICATIONS



CF & CM Series Performance Curve 65x40-250

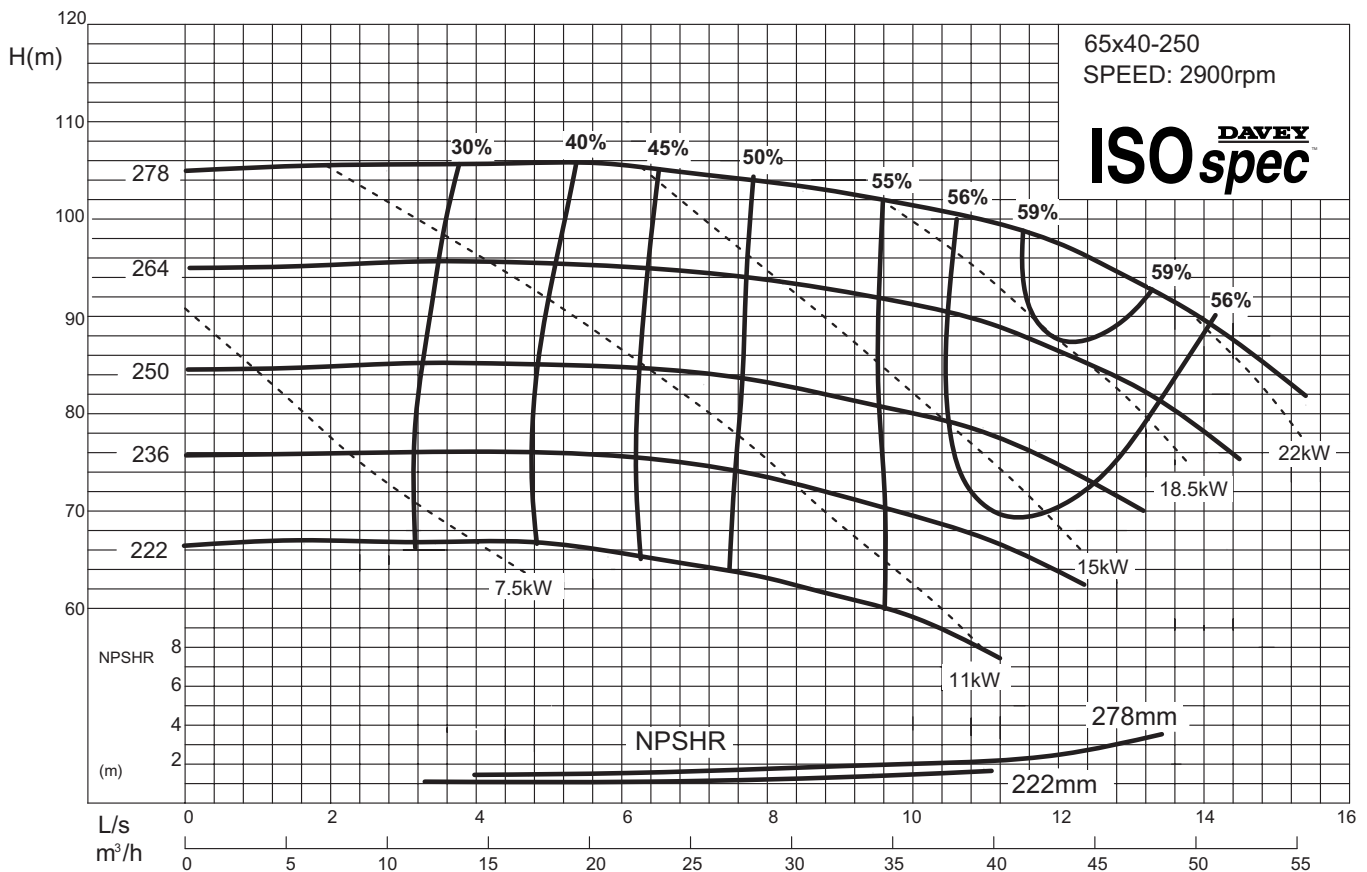
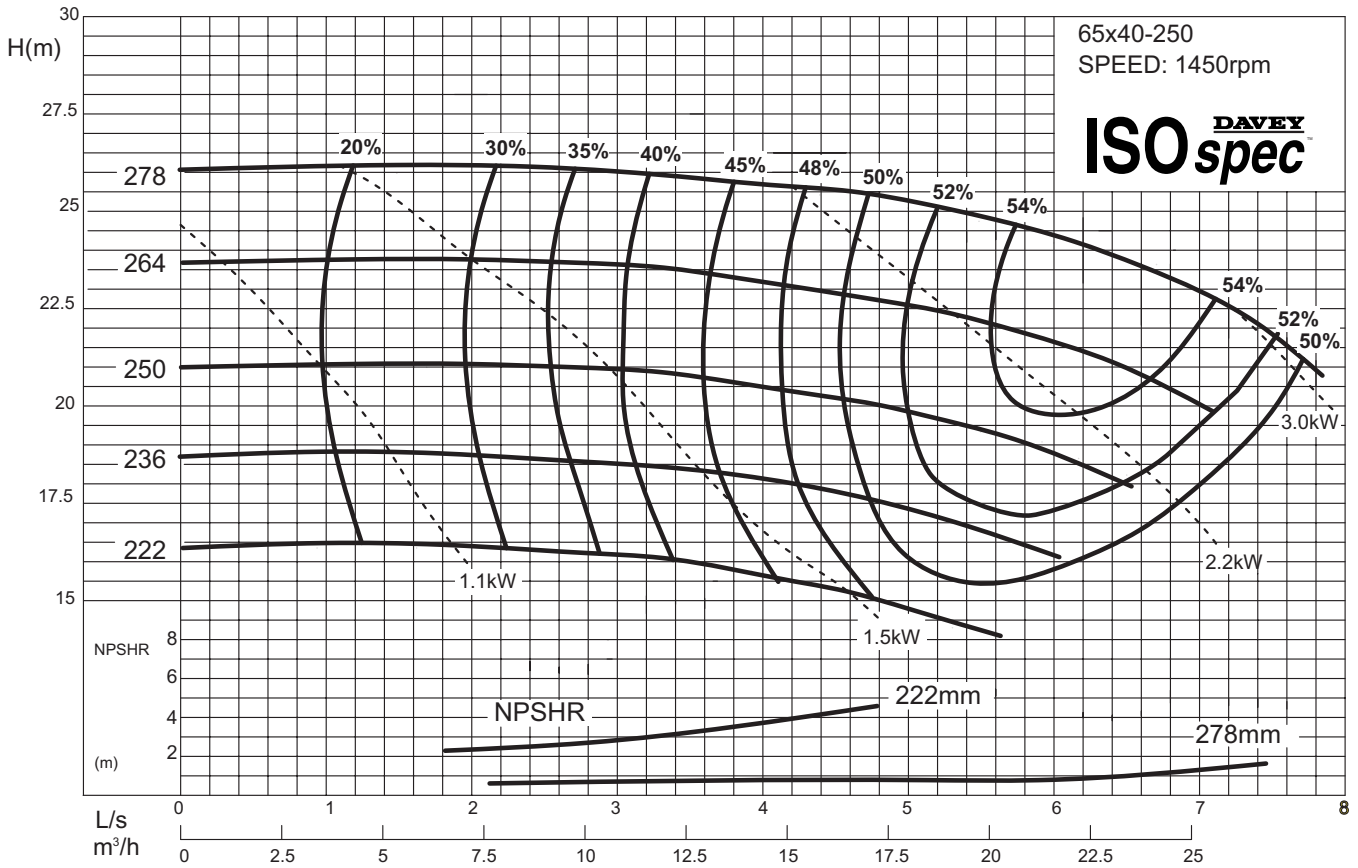

TECHNICAL SPECIFICATIONS



CF & CM Series Performance Curve 65x40-315

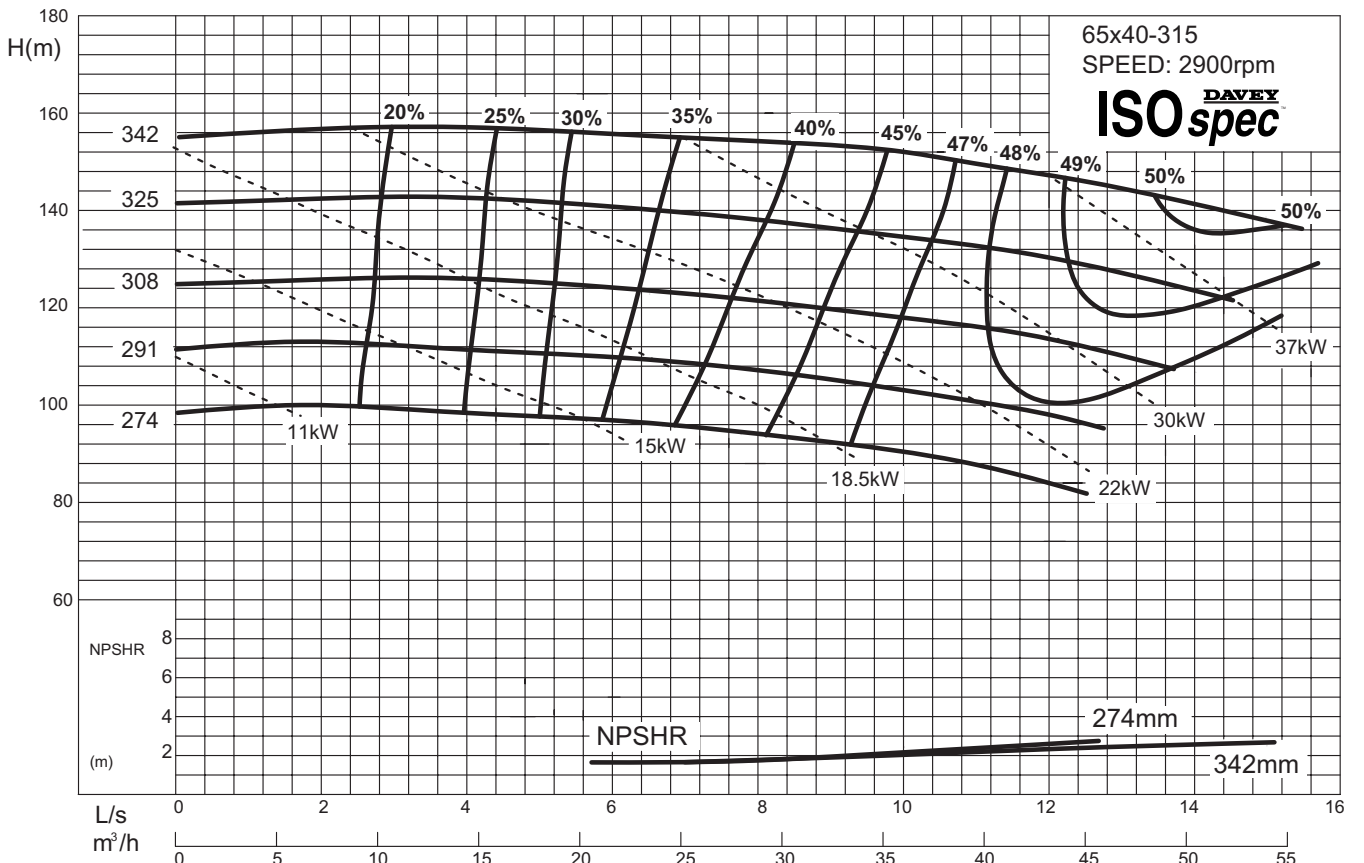
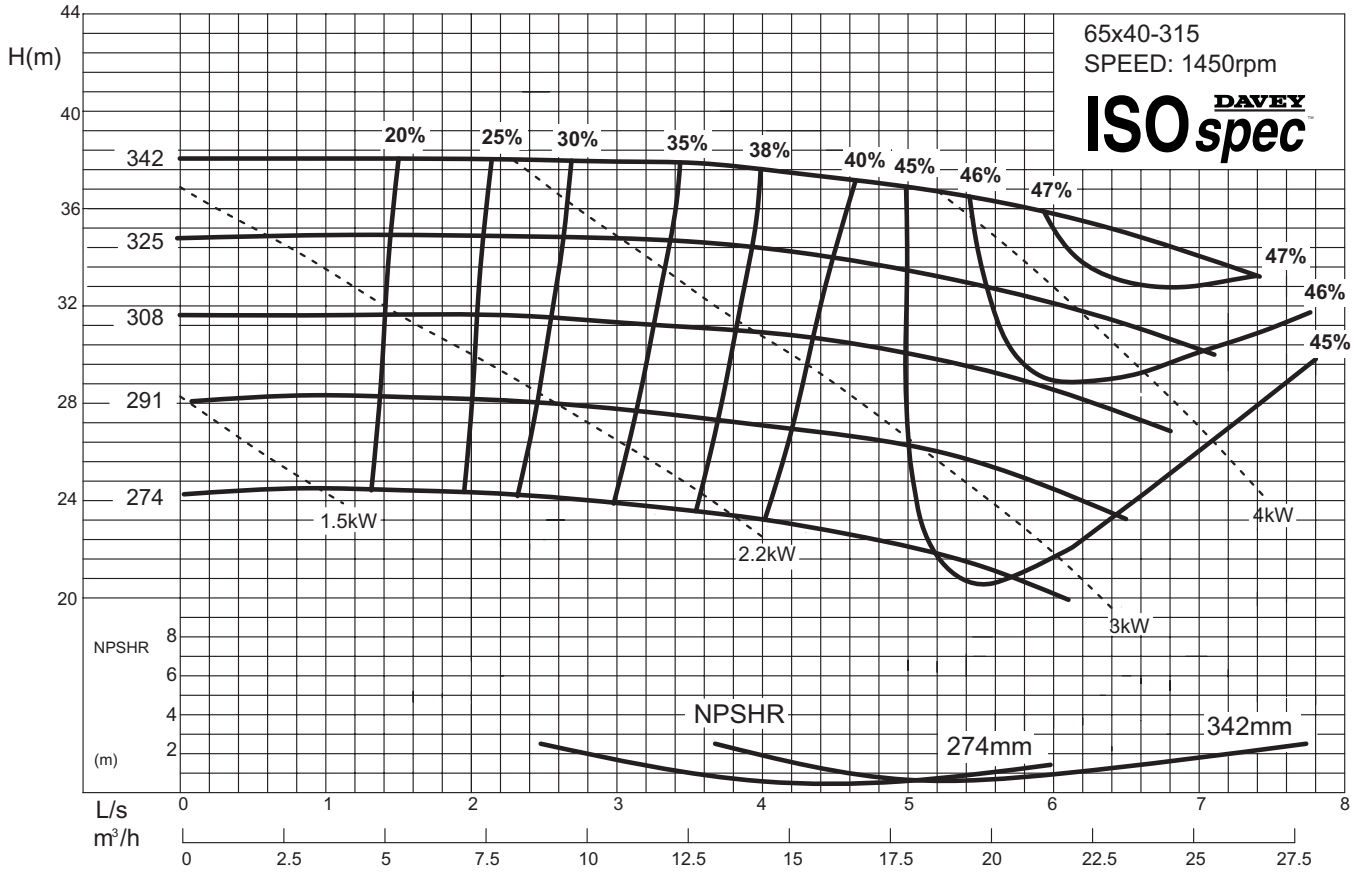

TECHNICAL SPECIFICATIONS



CF & CM Series Performance Curve 80x65-160

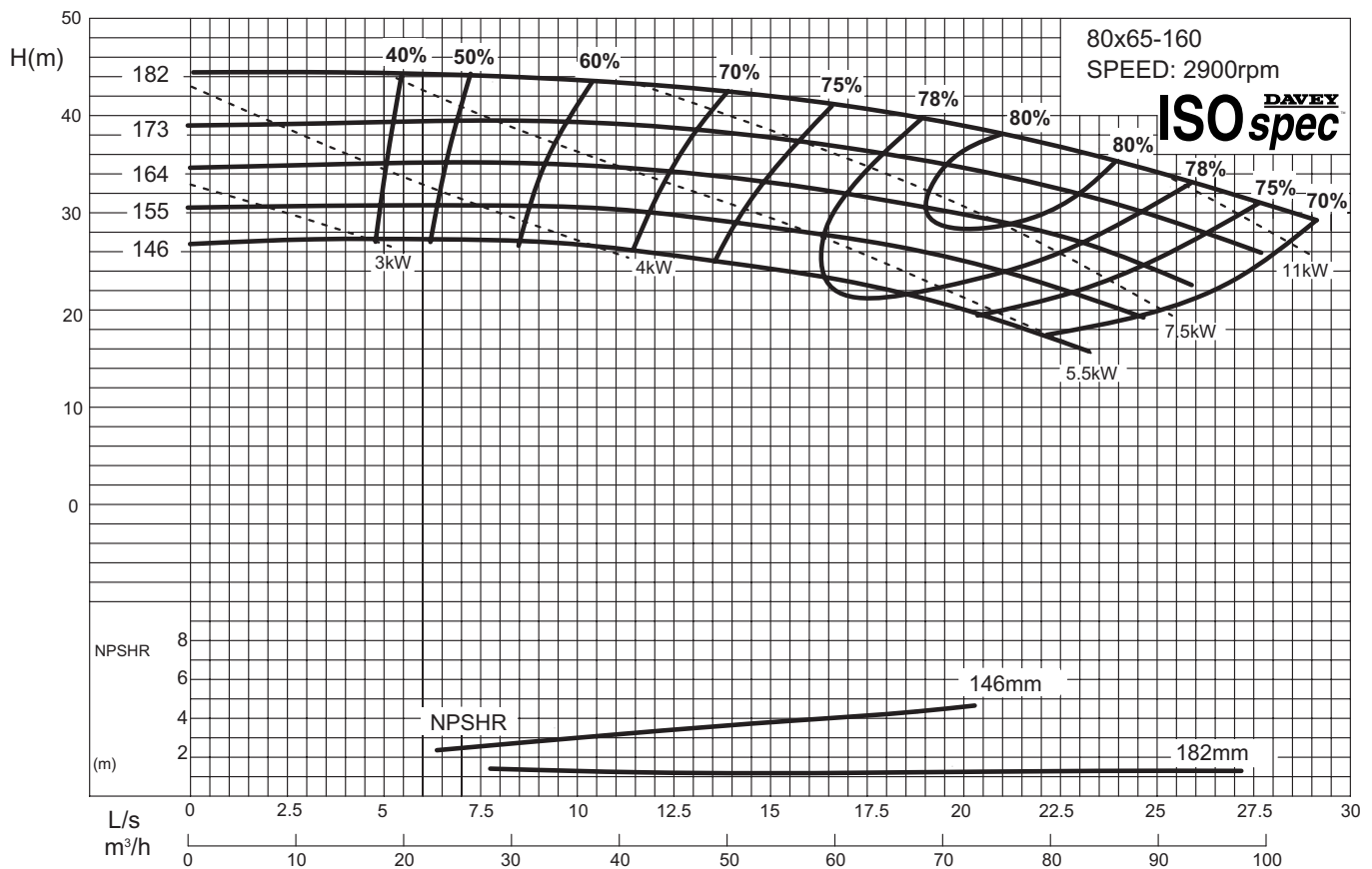
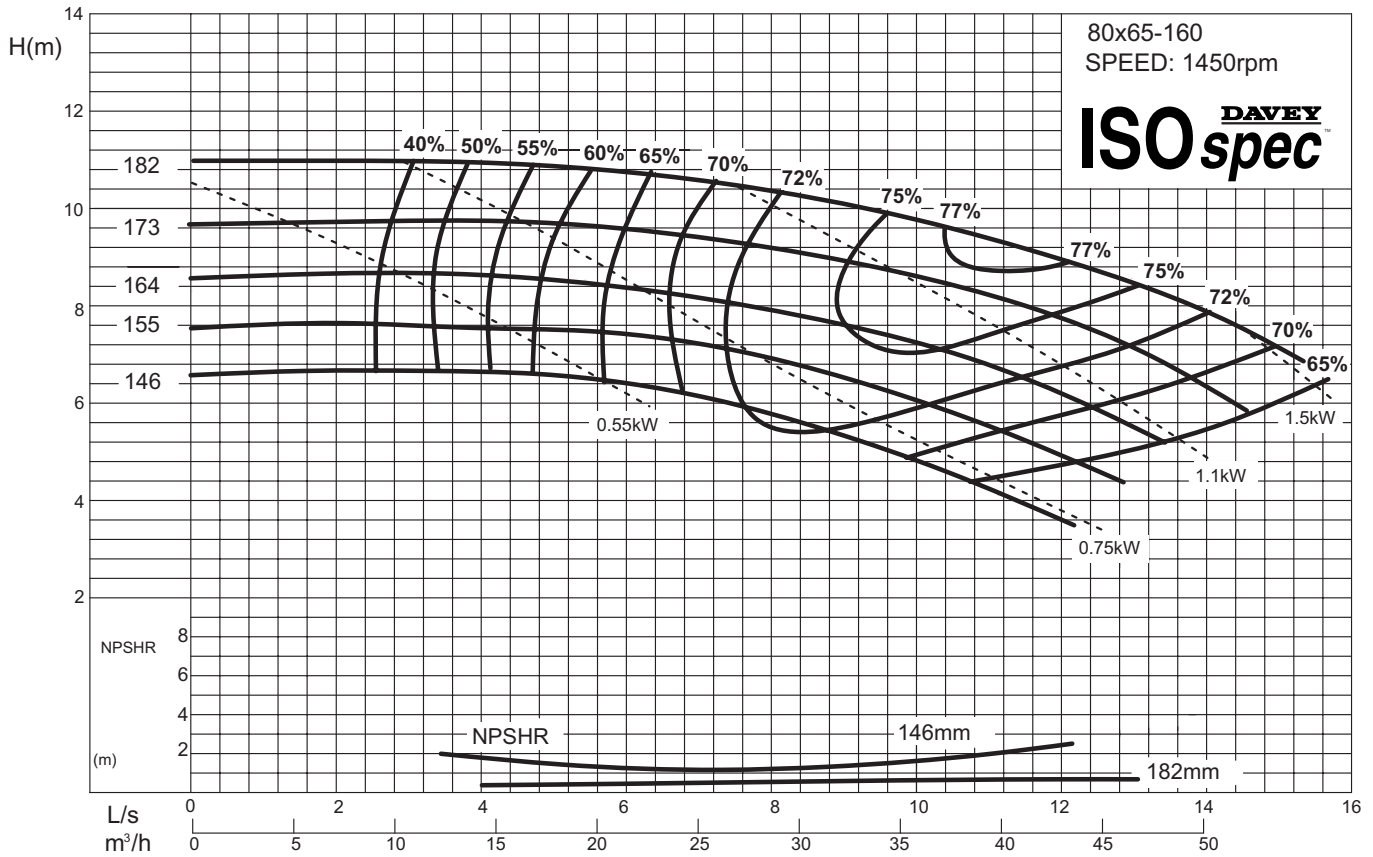

TECHNICAL SPECIFICATIONS

ISOspec DAVEY

CF & CM Series Performance Curve 80x50-200

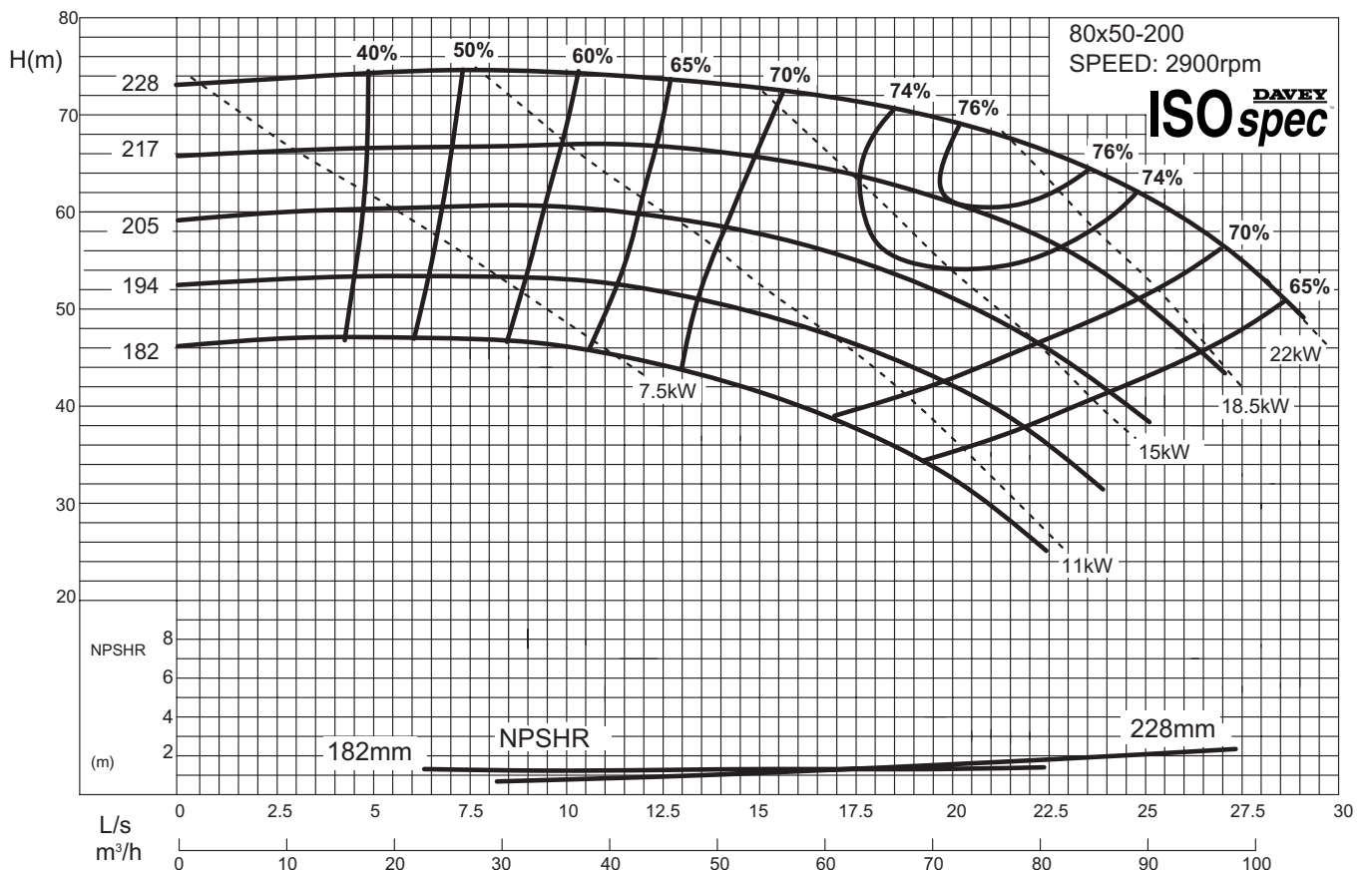
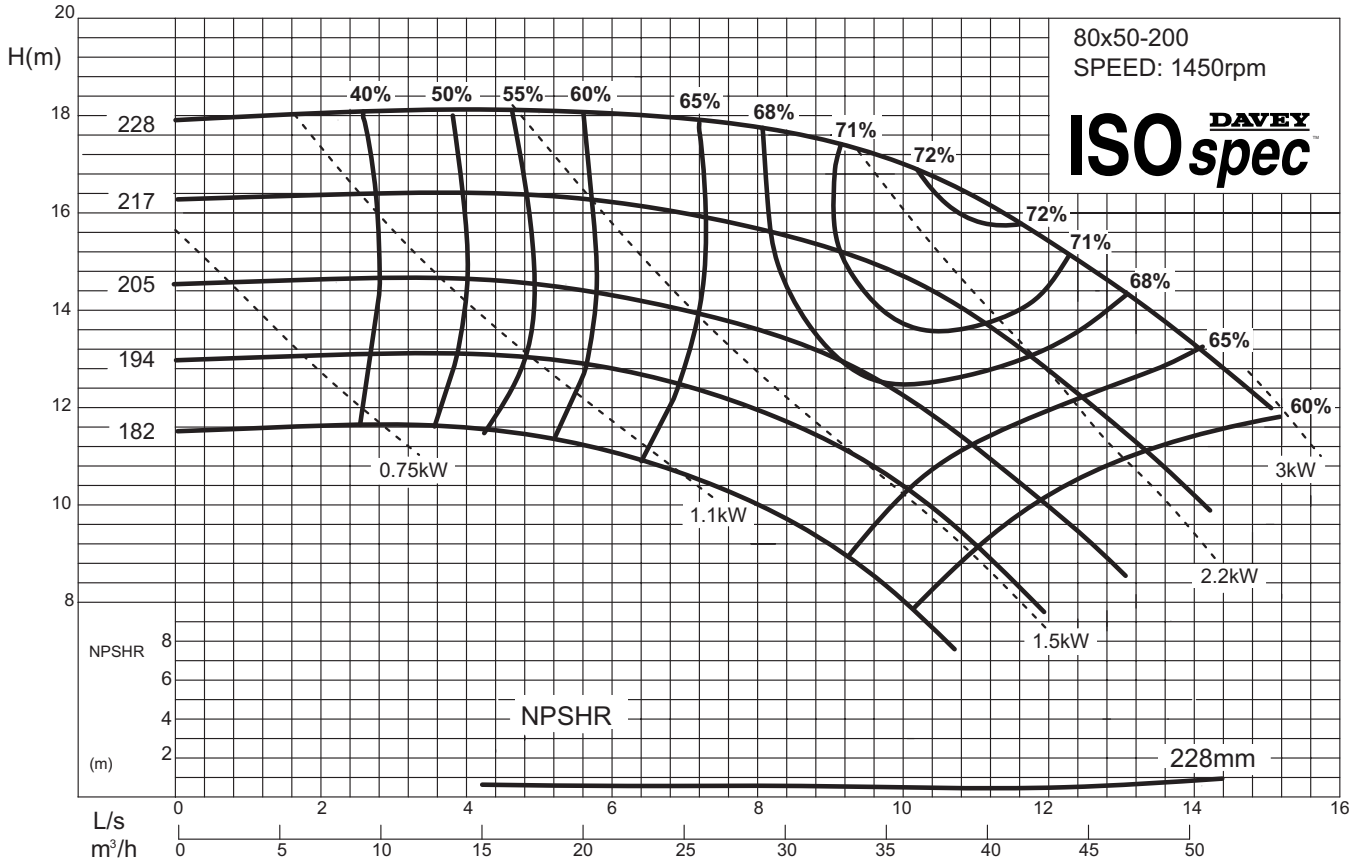

TECHNICAL SPECIFICATIONS



CF & CM Series Performance Curve 80x50-250

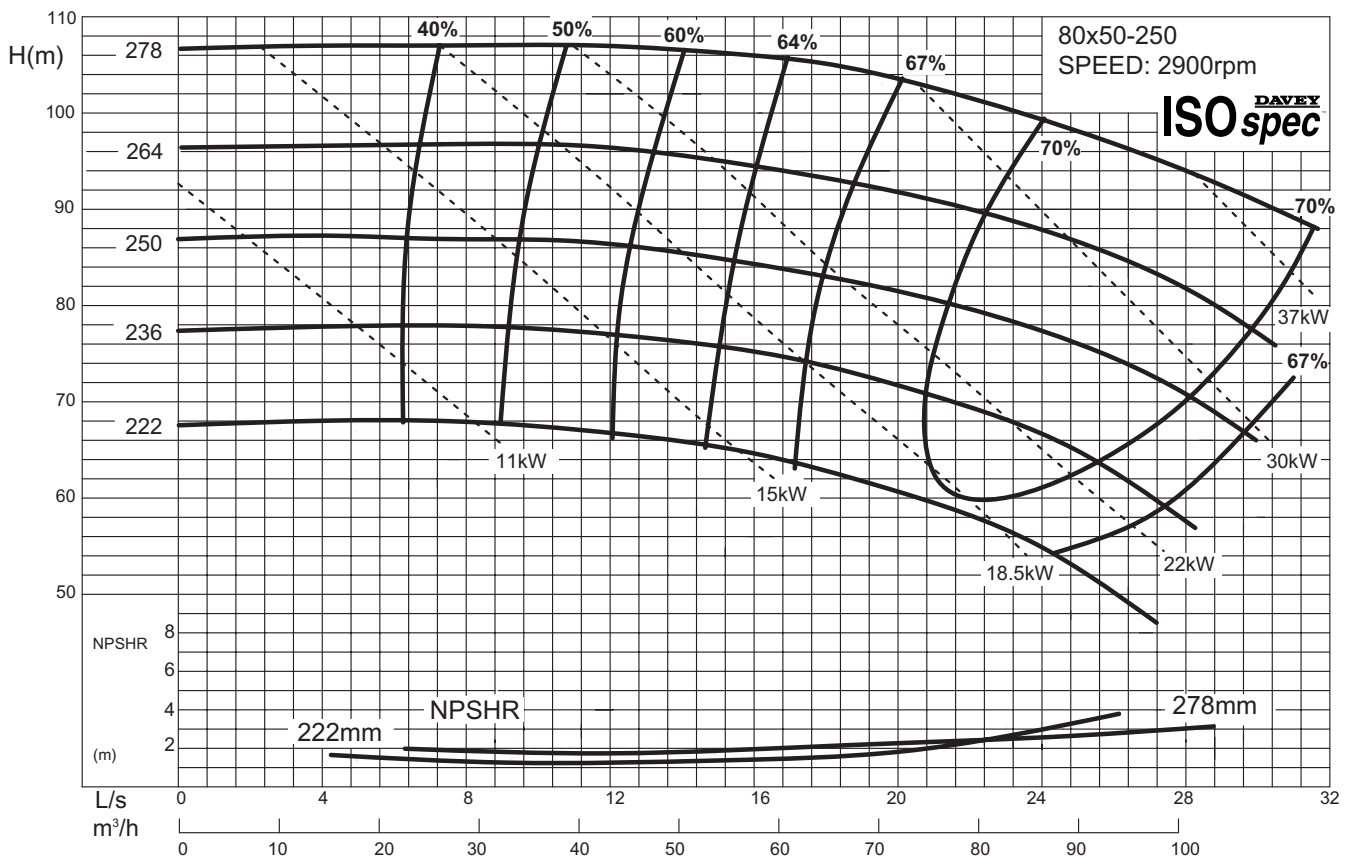
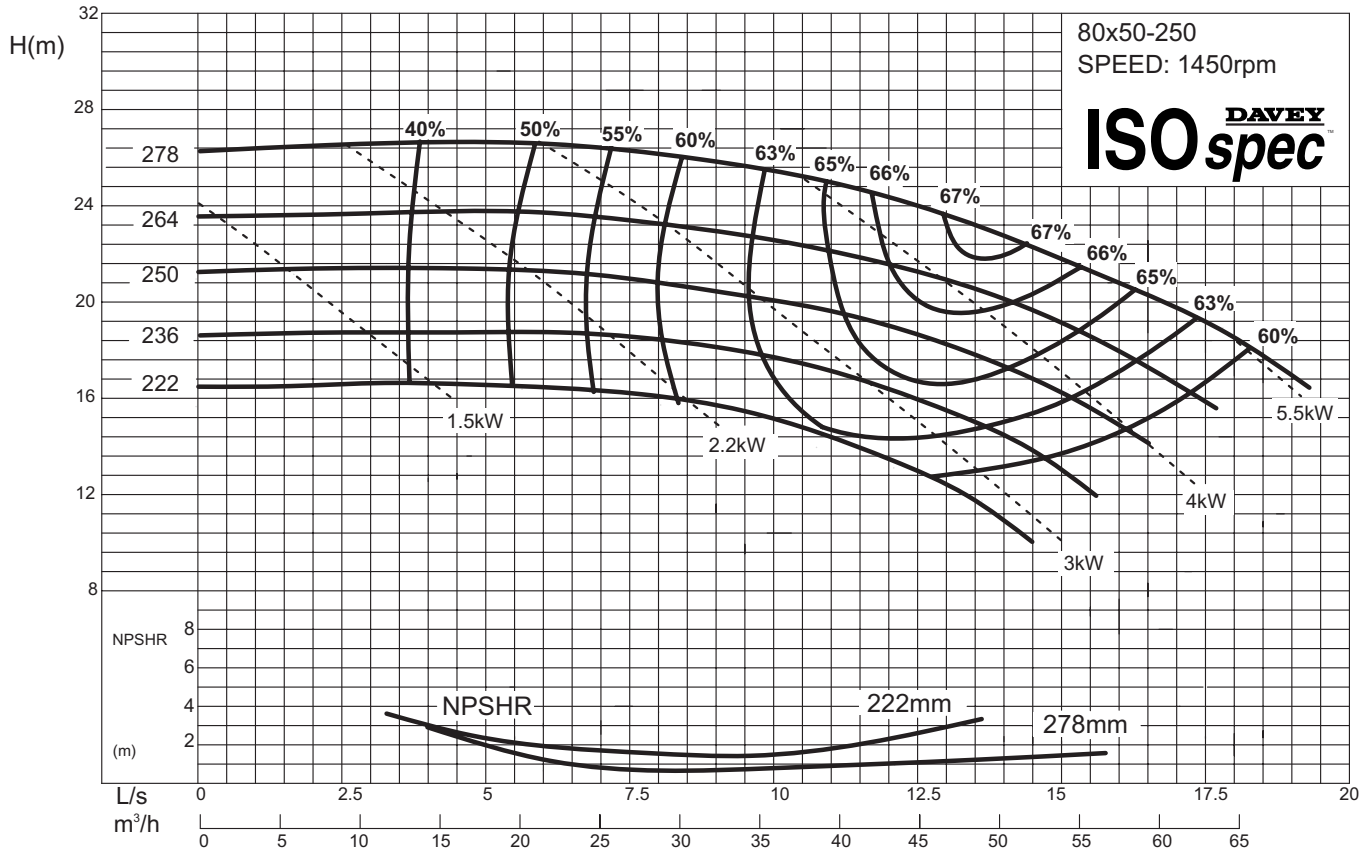

TECHNICAL SPECIFICATIONS

ISO DAVEY
spec

CF & CM Series Performance Curve 80x50-315

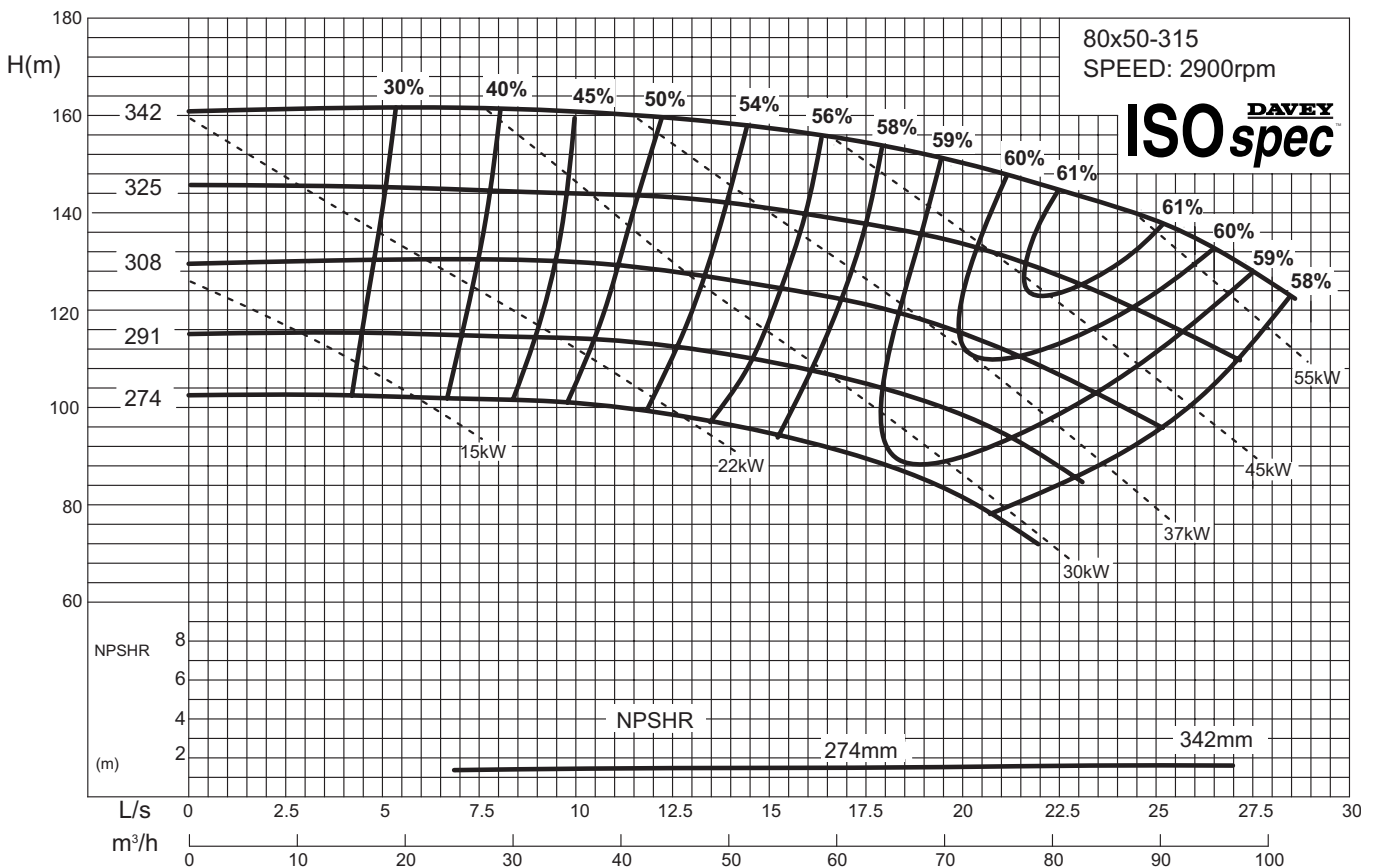
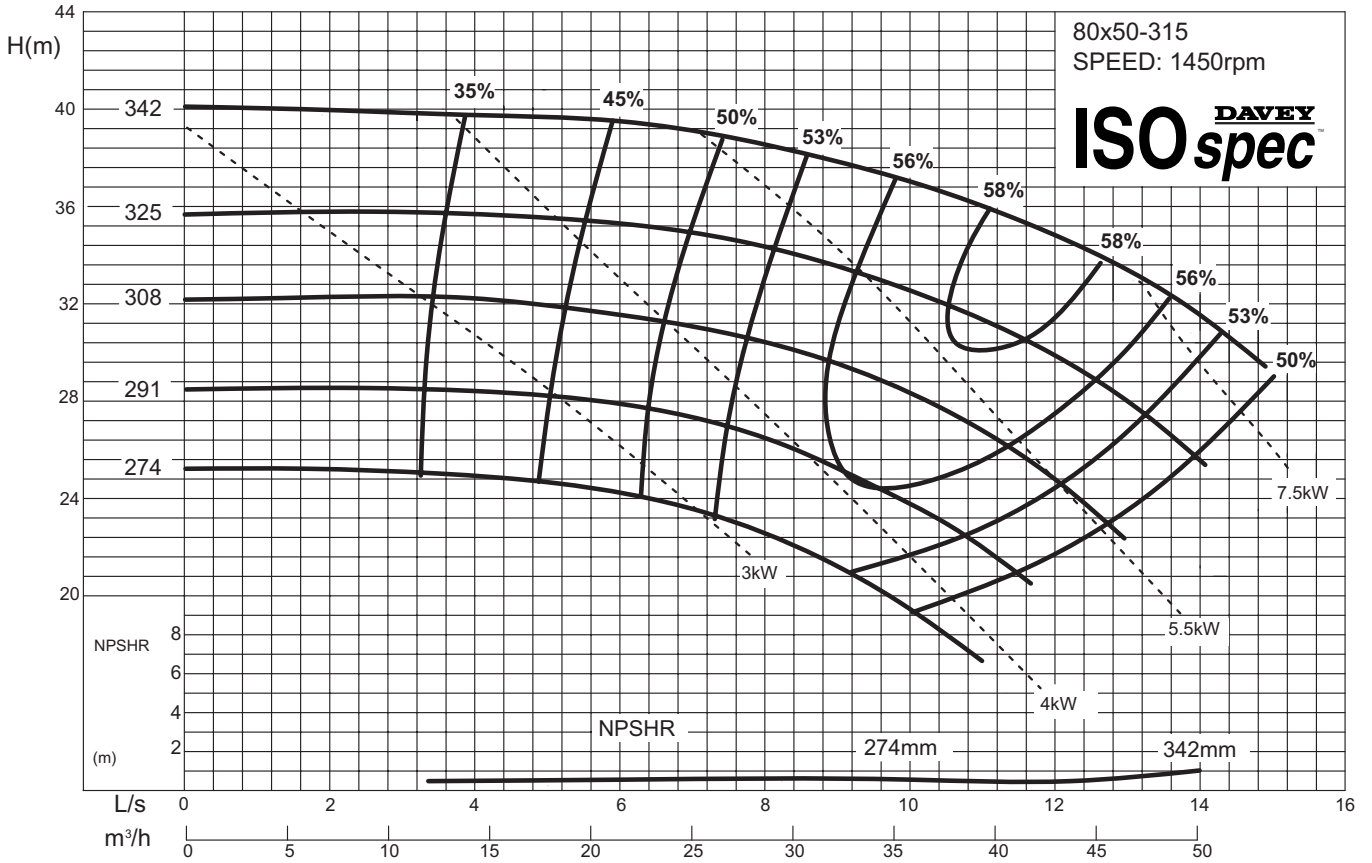

TECHNICAL SPECIFICATIONS



CF & CM Series Performance Curve 100x80-160

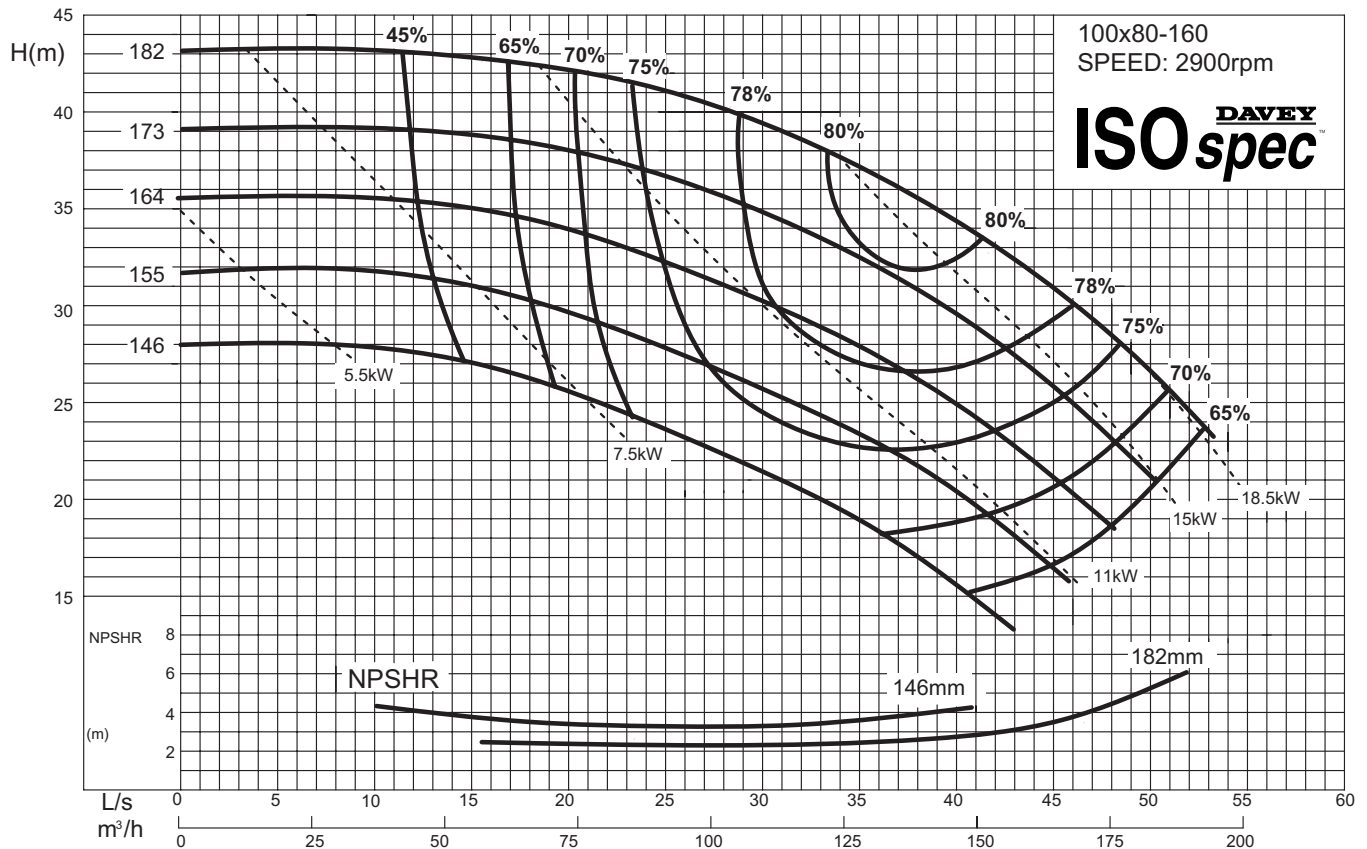
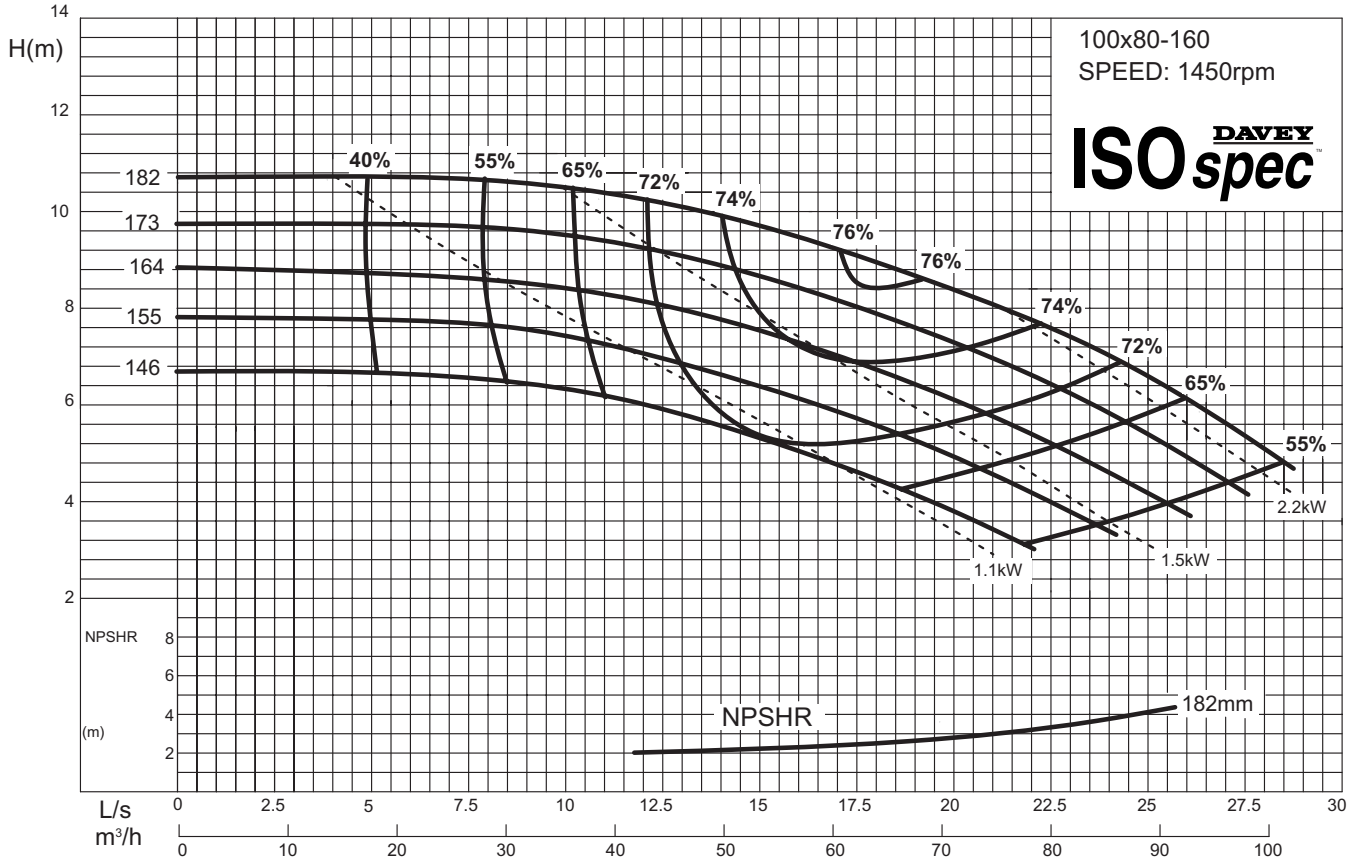

TECHNICAL SPECIFICATIONS

ISOspec[®] **DAVEY**

CF & CM Series Performance Curve 100x65-200

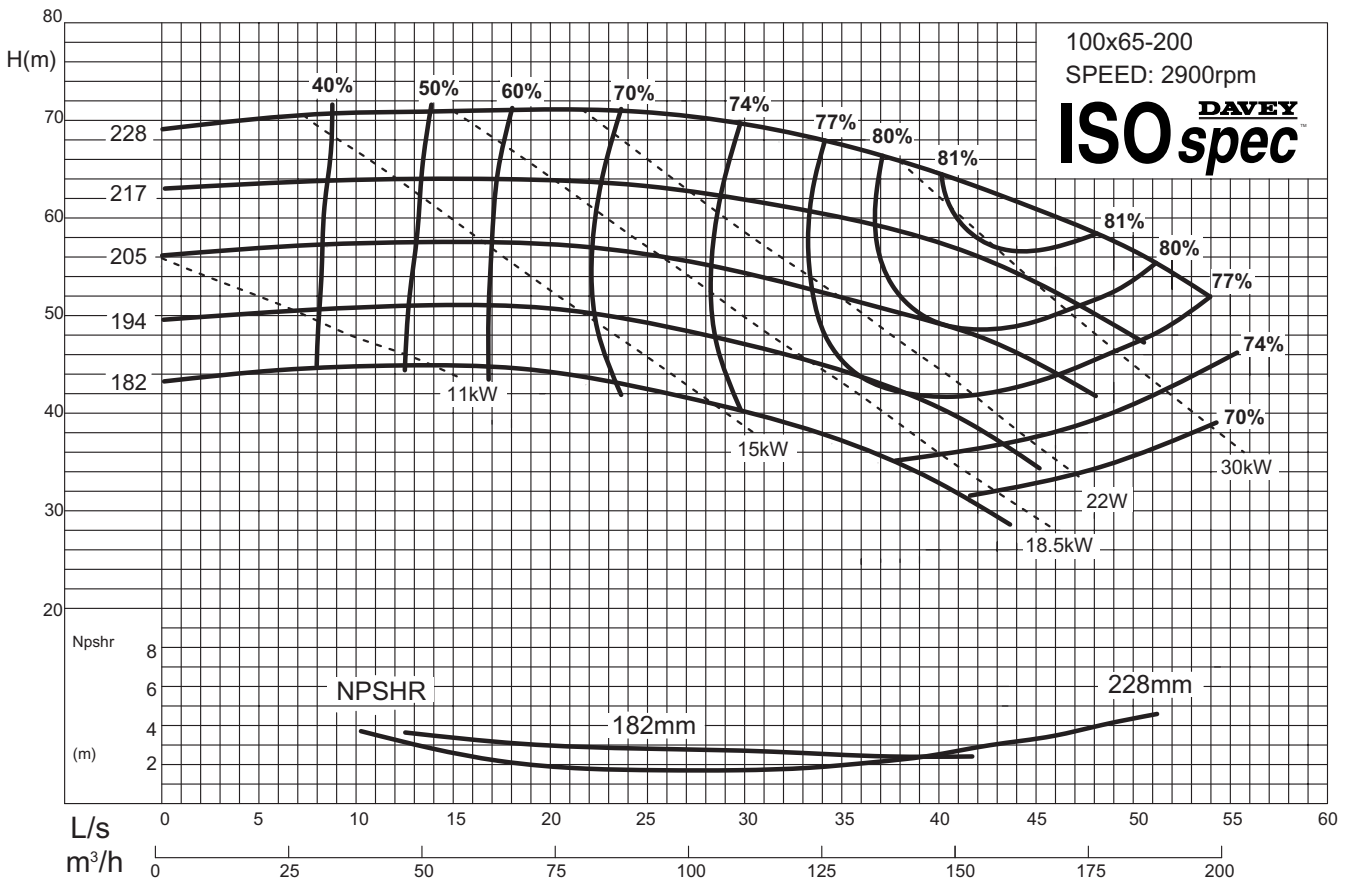
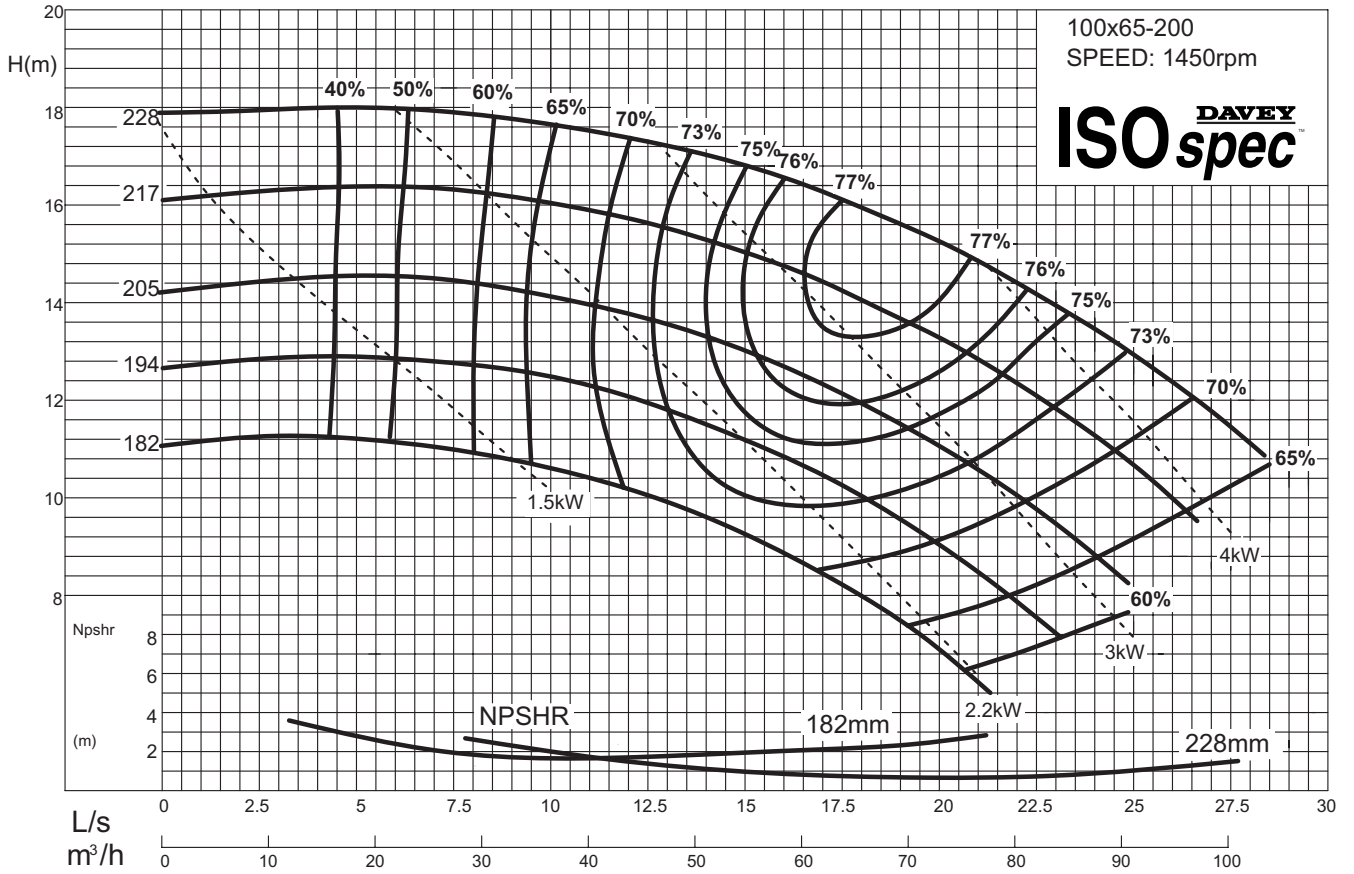

TECHNICAL SPECIFICATIONS

ISOspec DAVEY

CF & CM Series Performance Curve 100x65-250

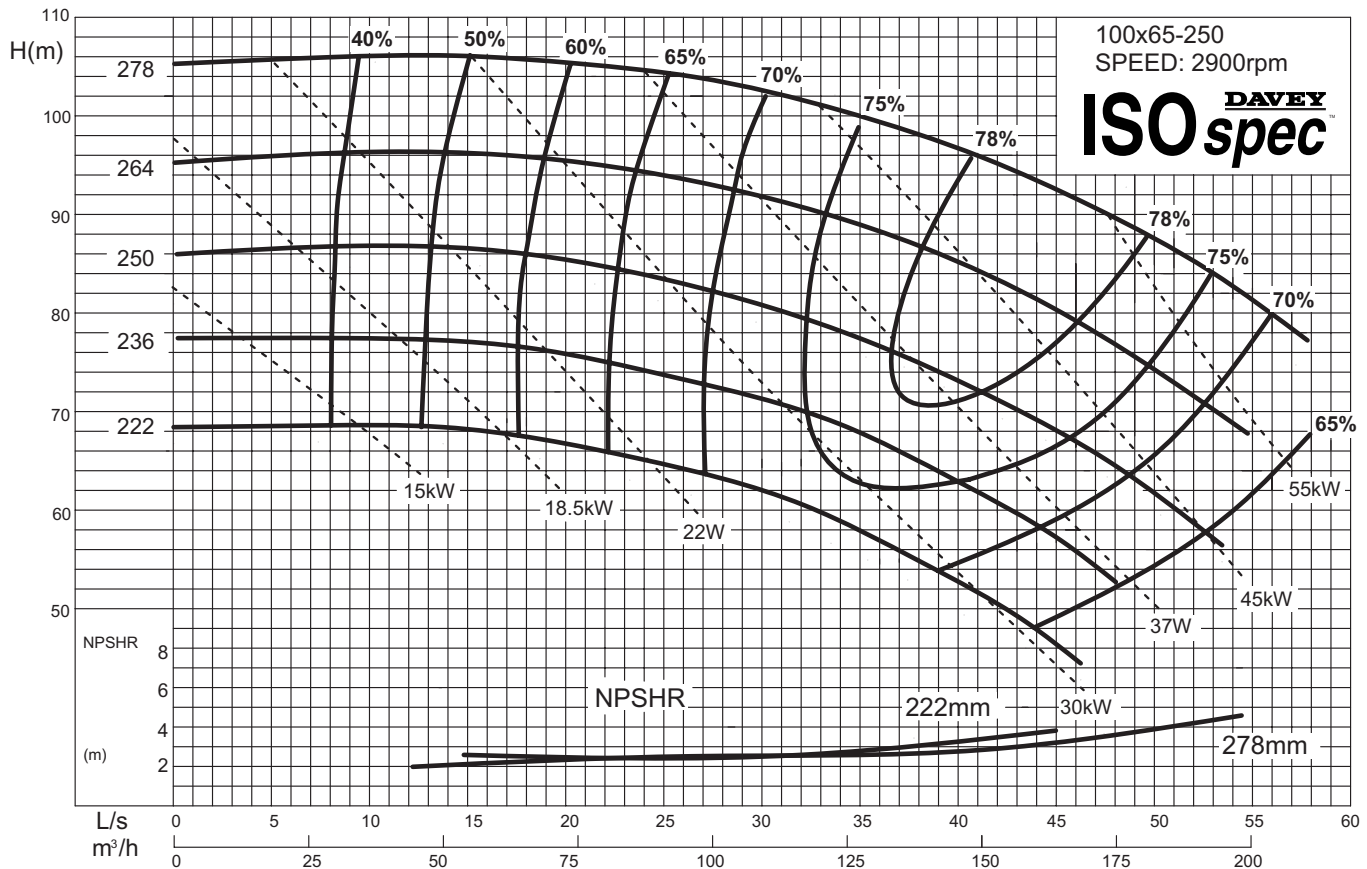
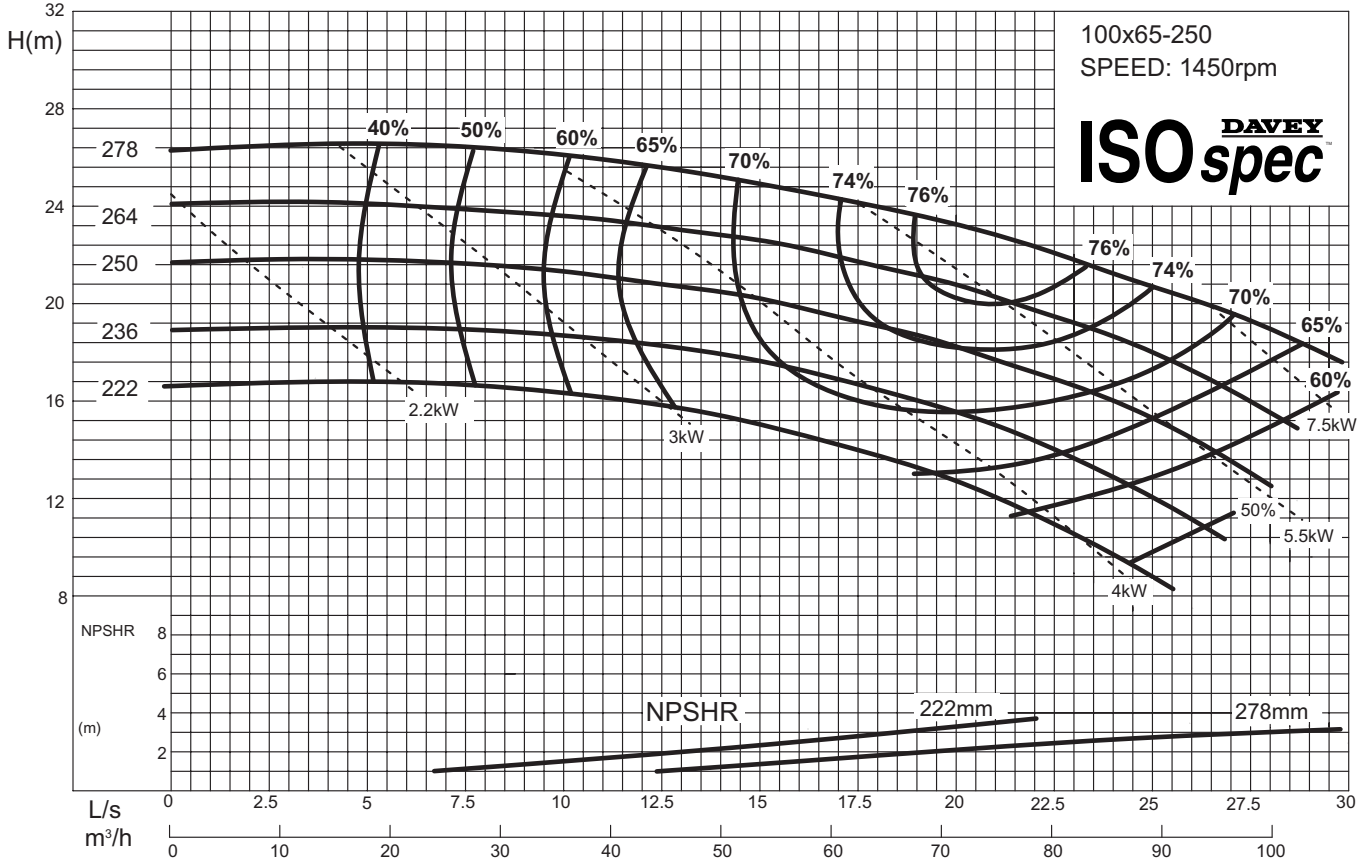

TECHNICAL SPECIFICATIONS

ISOspec[®] DAVEY

CF & CM Series Performance Curve 100x65-315

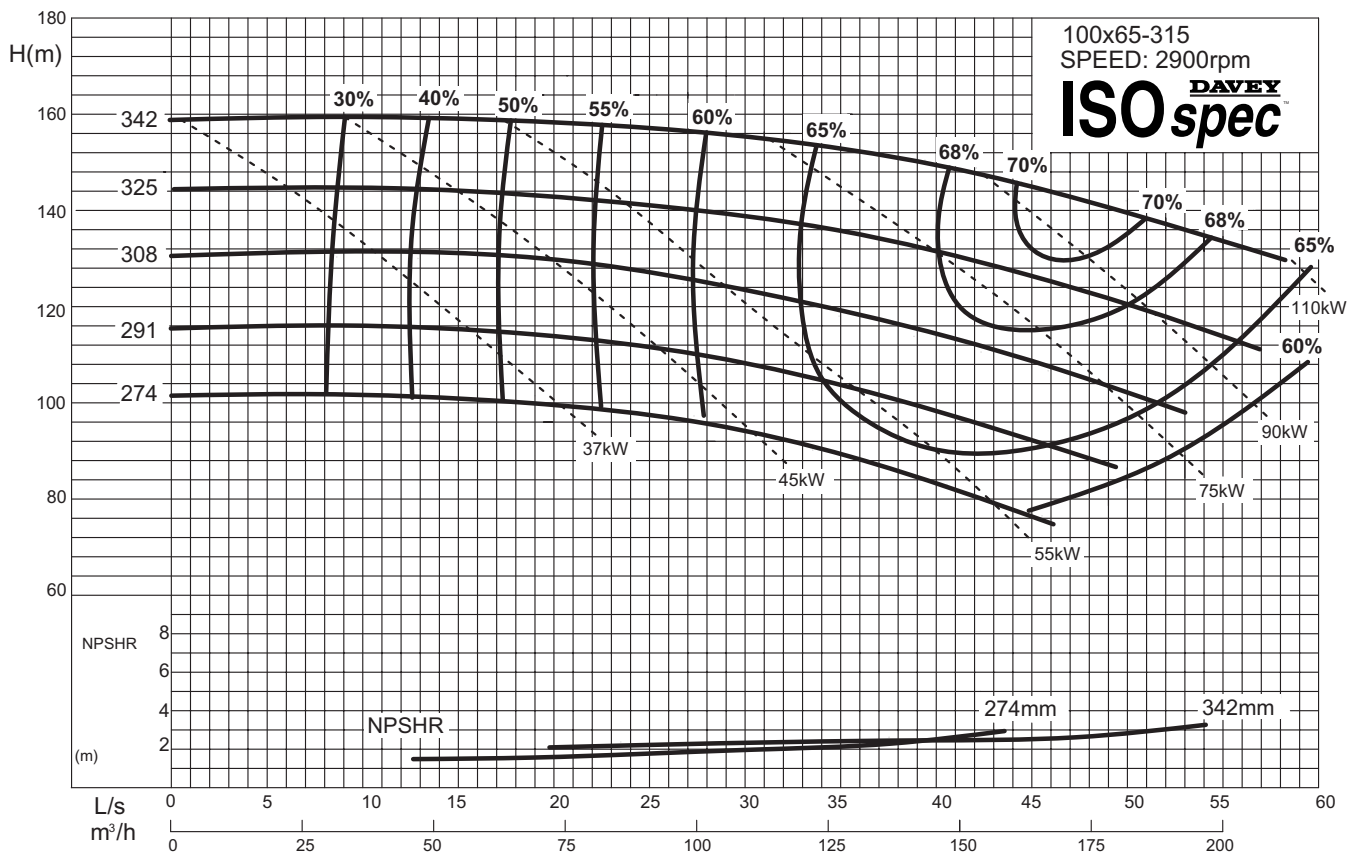
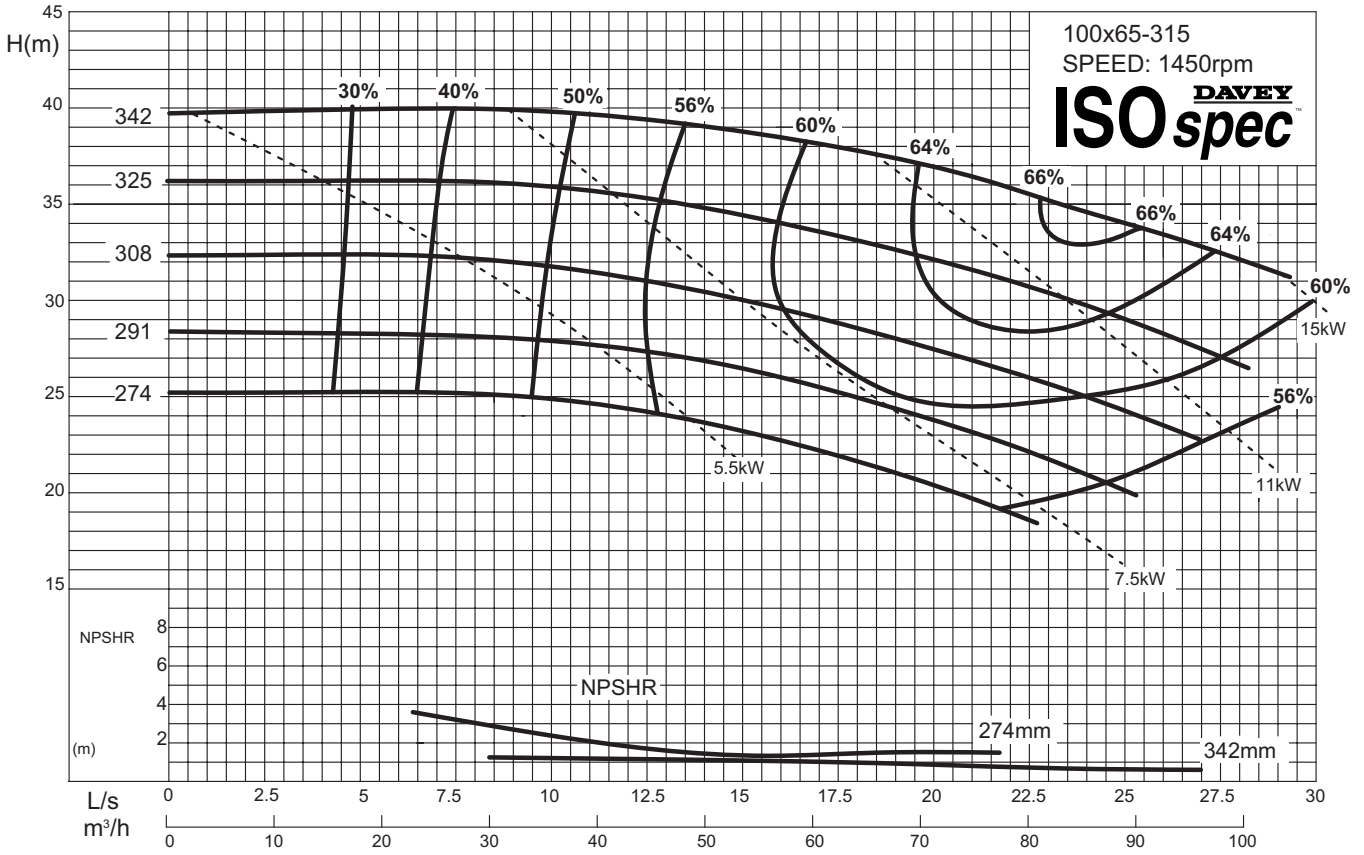

TECHNICAL SPECIFICATIONS

ISOspec DAVEY

CF Series Performance Curve 125x80-400

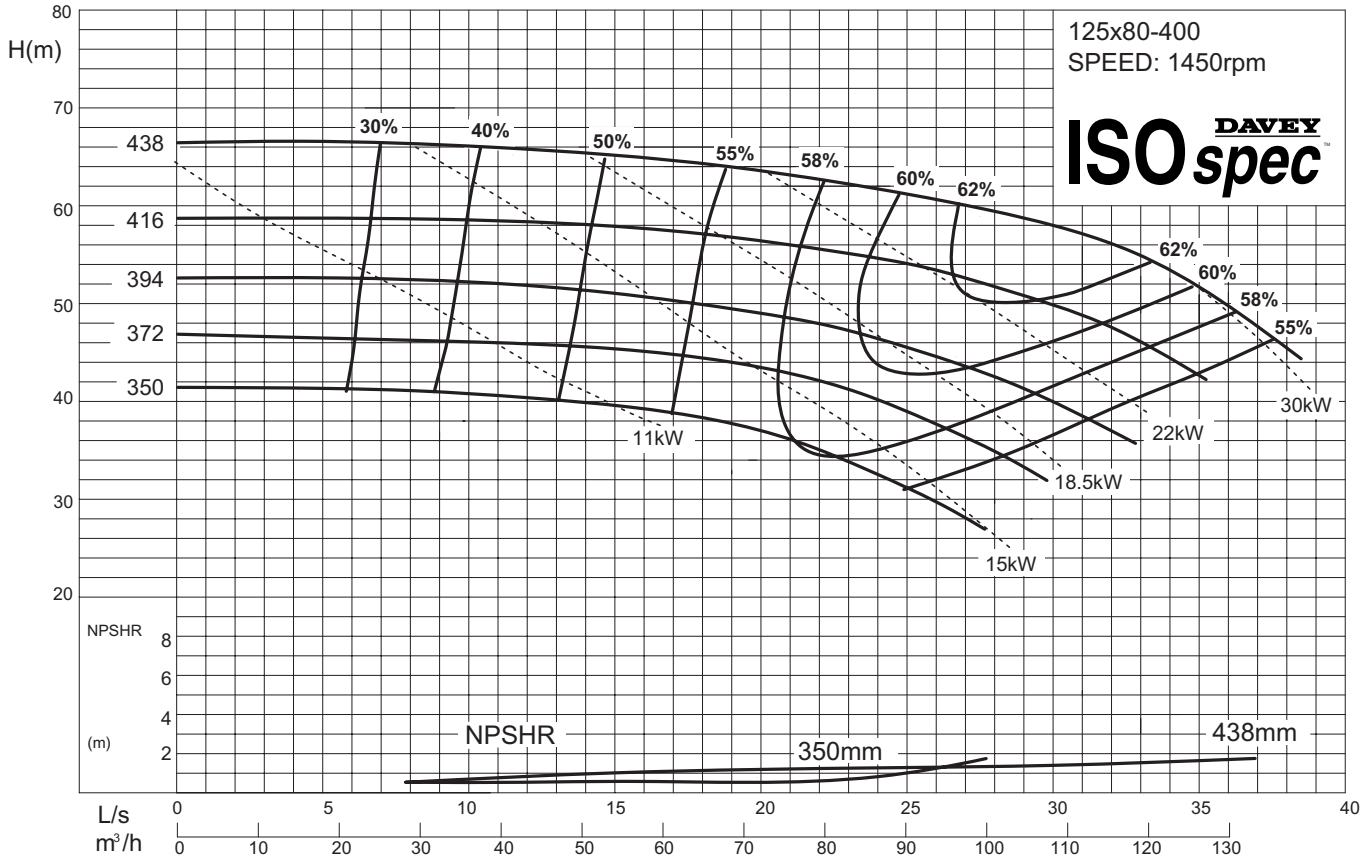

TECHNICAL SPECIFICATIONS



CF & CM Series Performance Curve 125x100-200

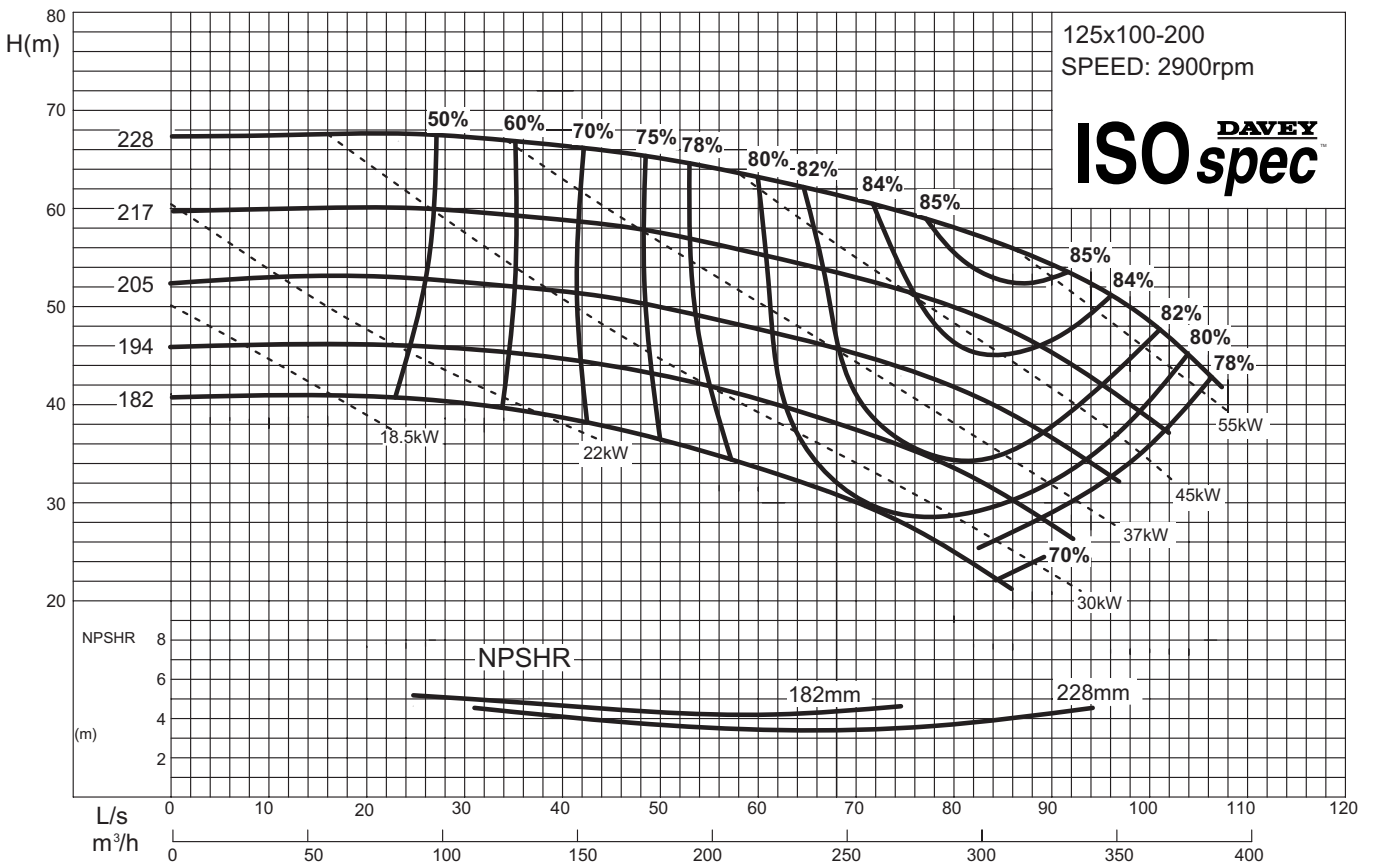
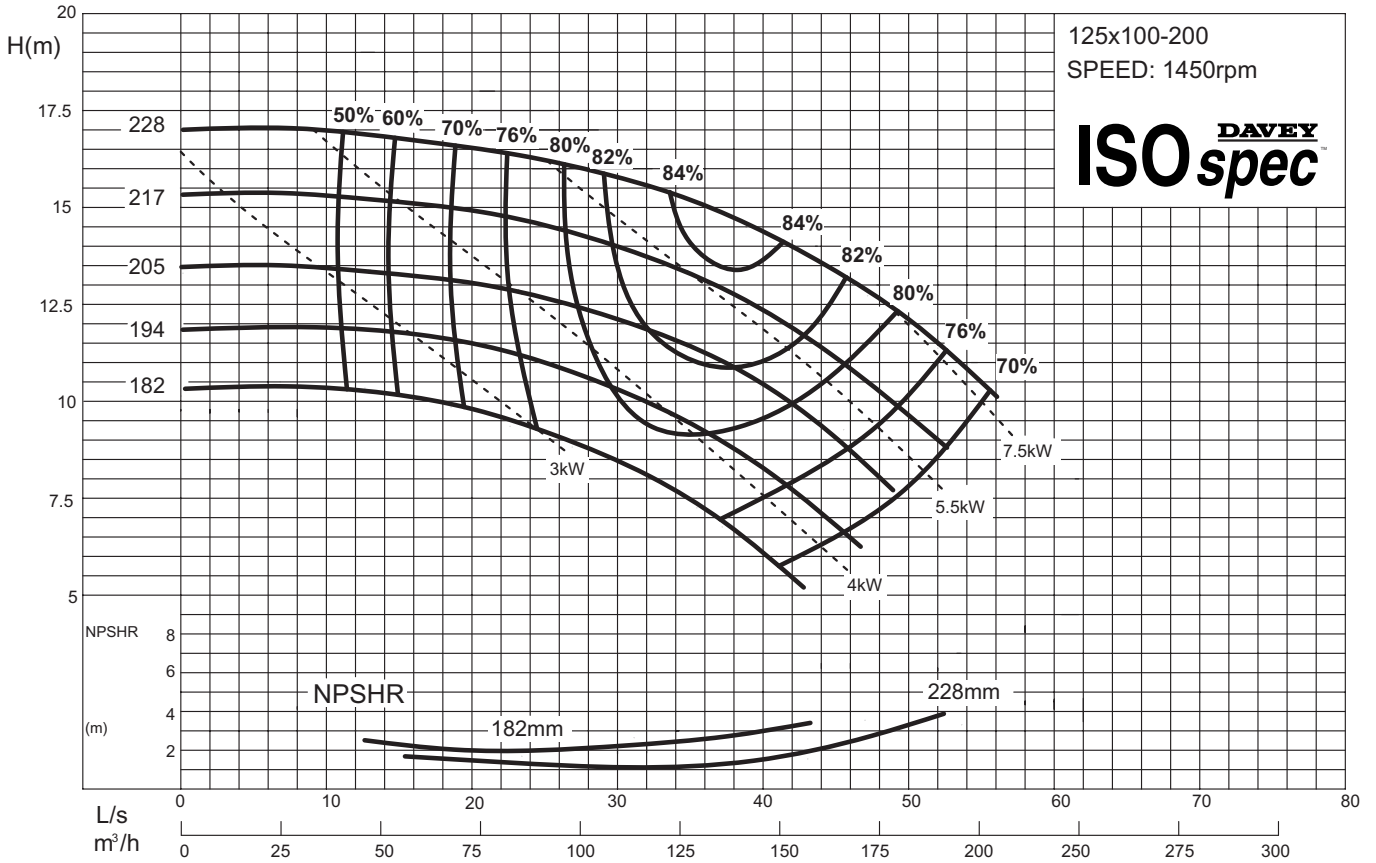

TECHNICAL SPECIFICATIONS



CF & CM Series Performance Curve 125x100-250

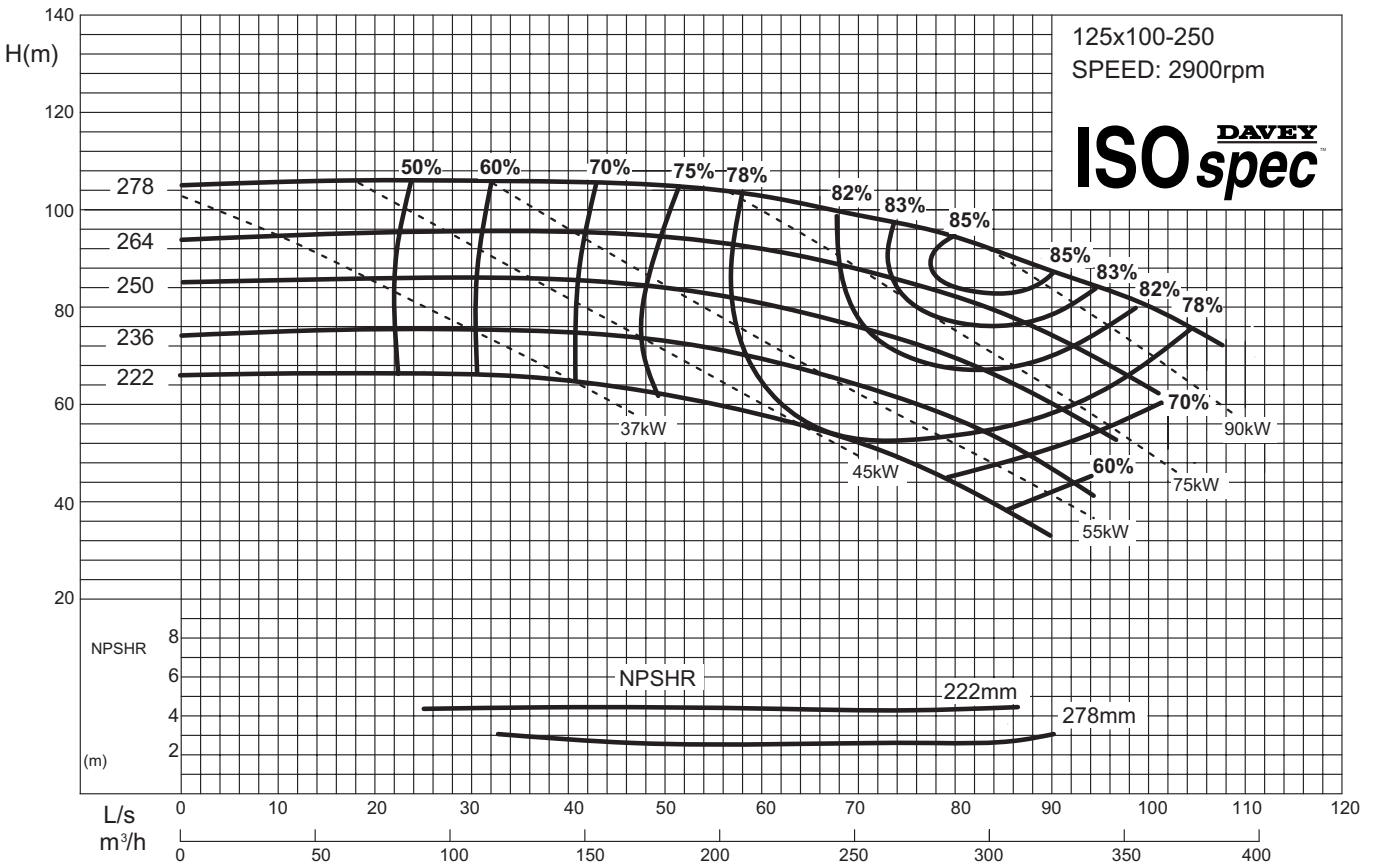
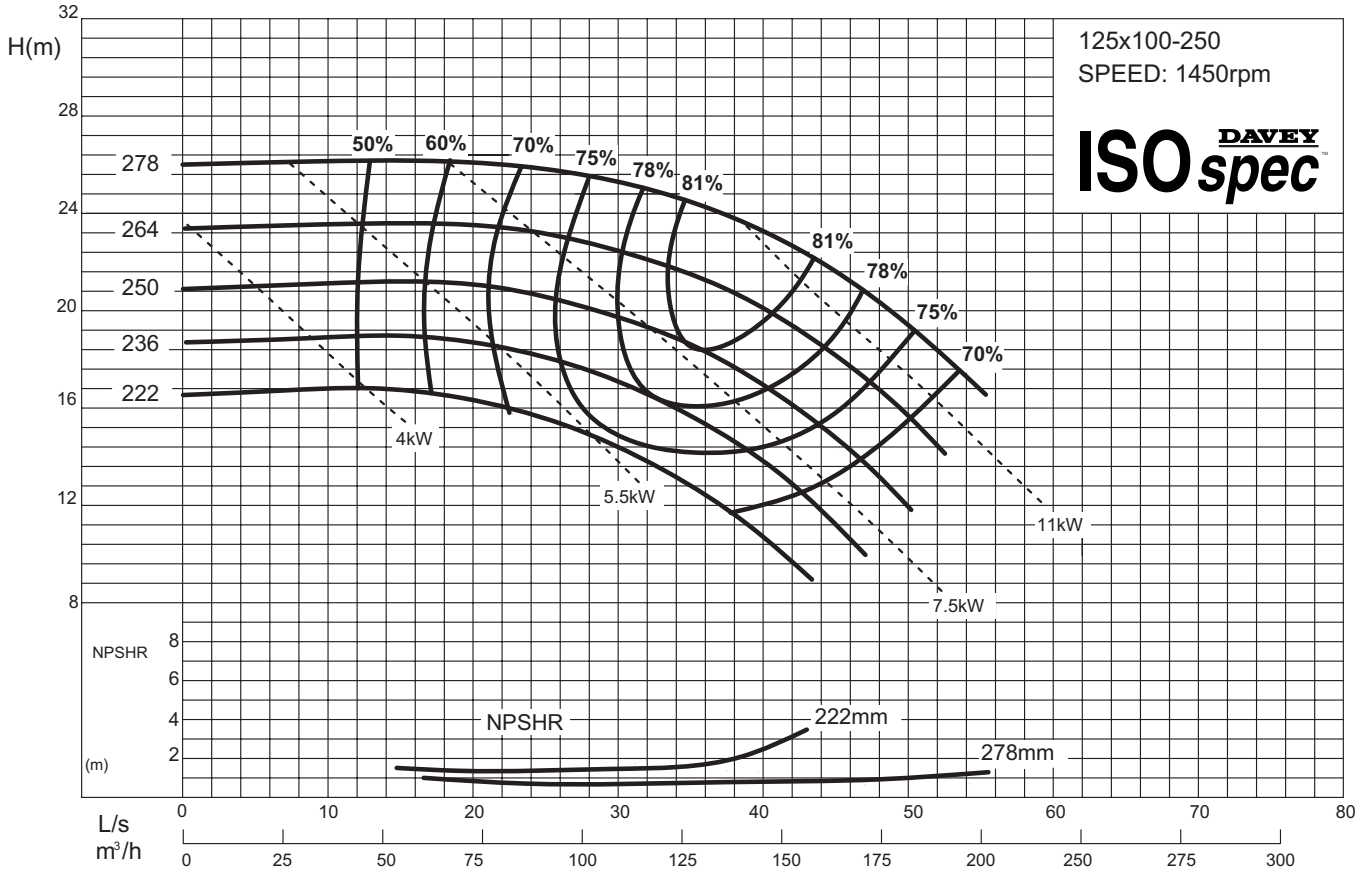

TECHNICAL SPECIFICATIONS

ISO spec DAVEY

CF & CM Series Performance Curve 125x100-315

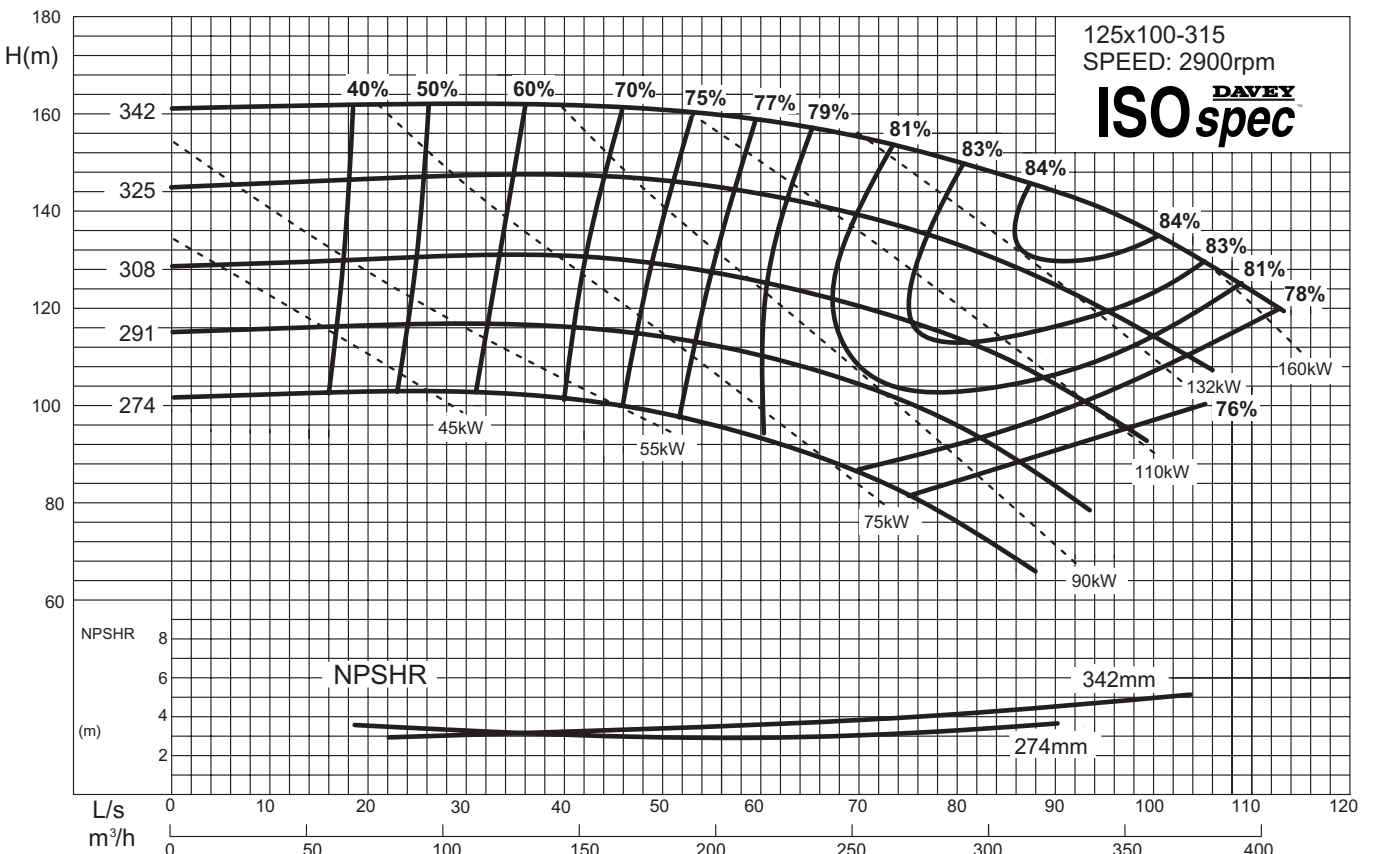
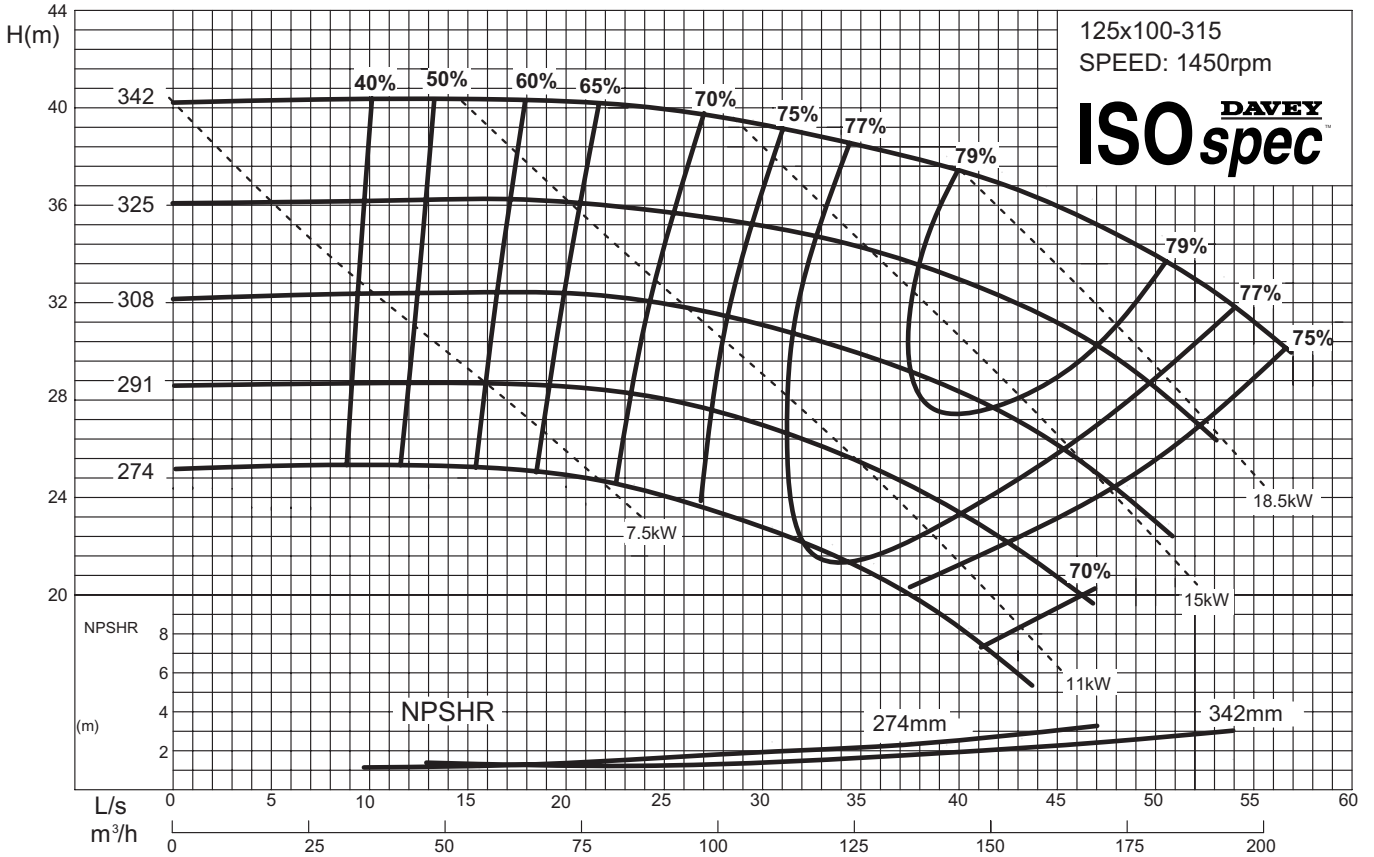

TECHNICAL SPECIFICATIONS

ISOspec DAVEY

CF Series Performance Curve 125x100-400

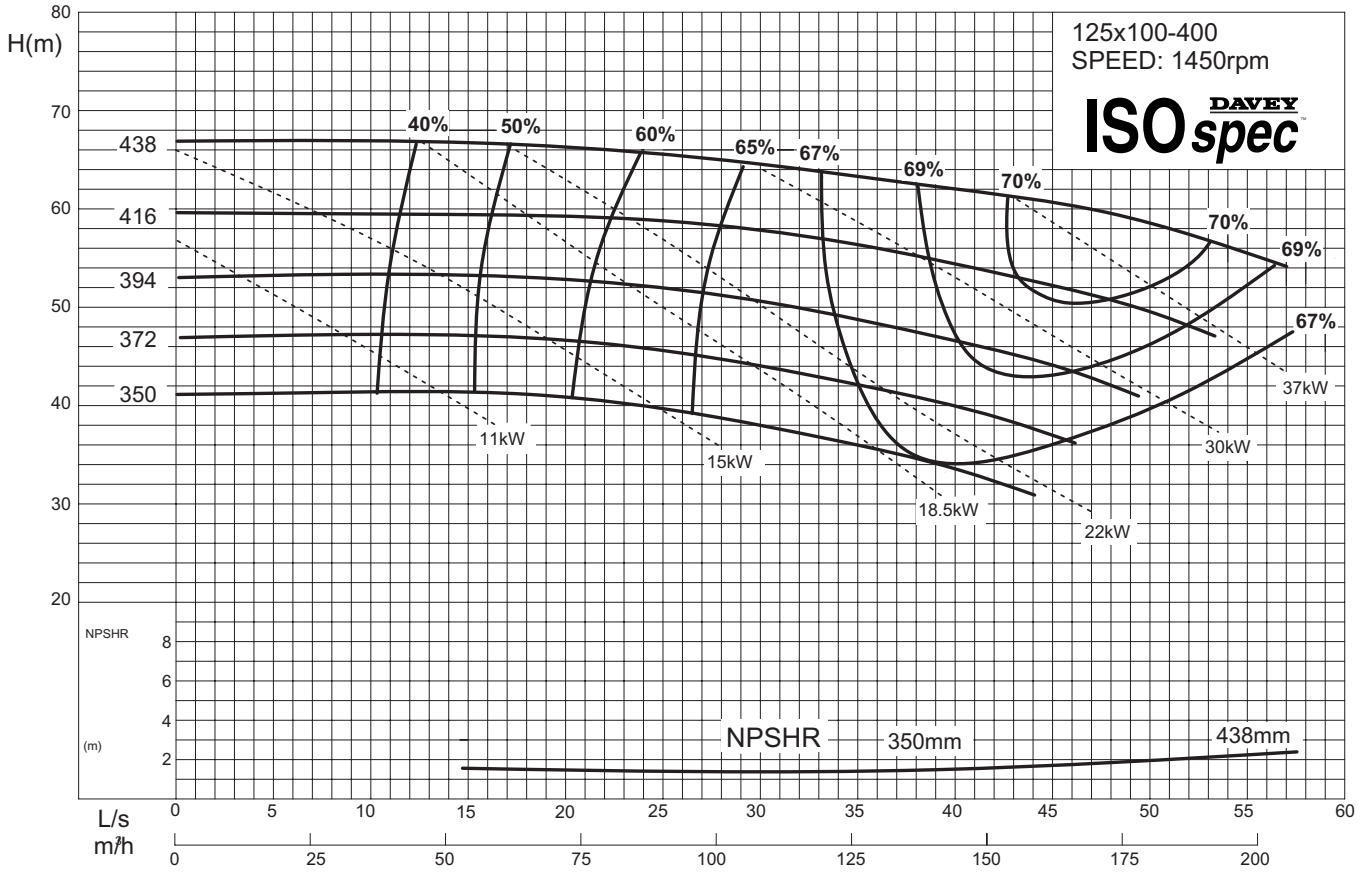

CF Series Performance Curve 125x100-500

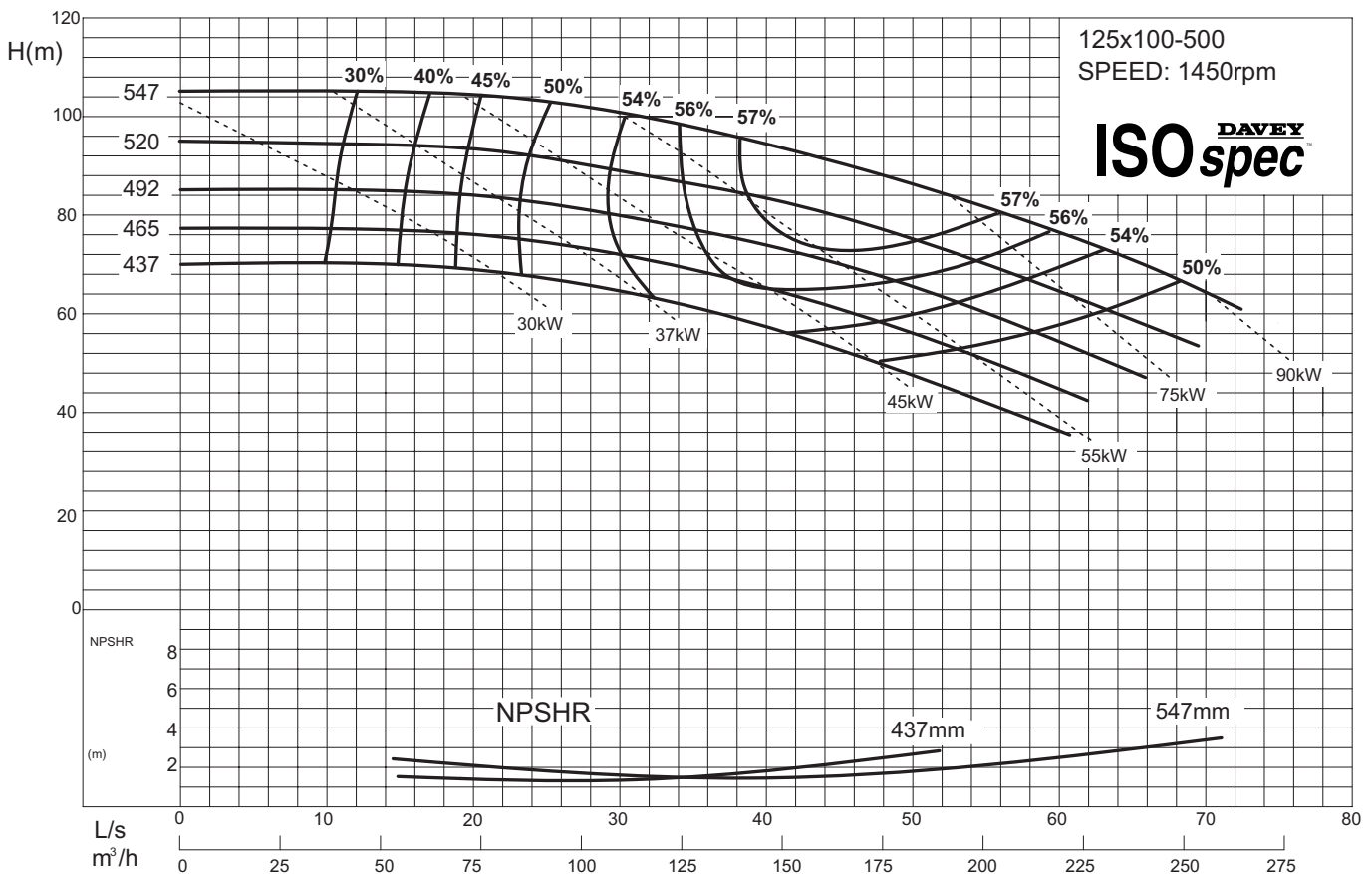

TECHNICAL SPECIFICATIONS

ISO spec DAVEY®

CF Series Performance Curve 150x125-250

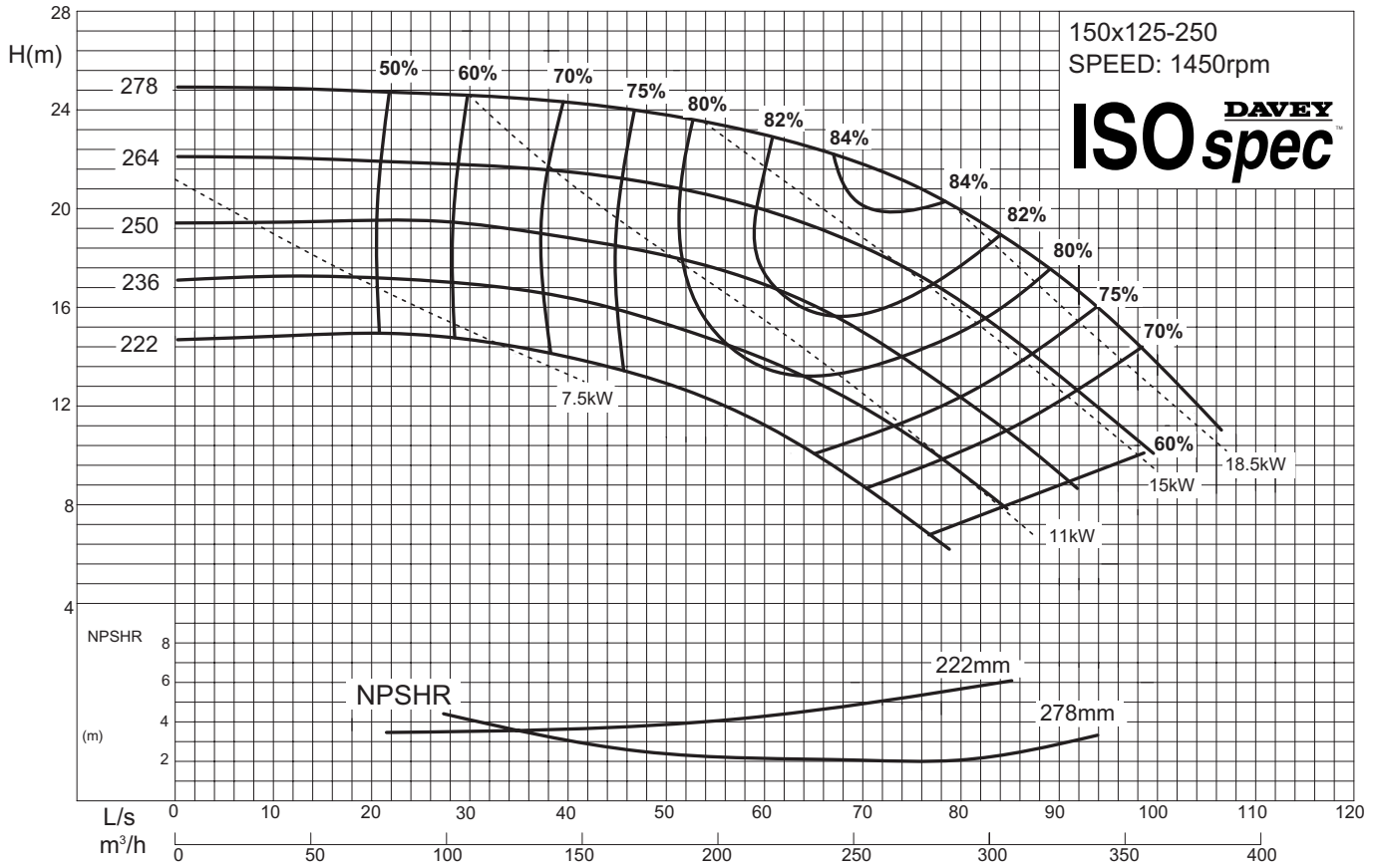

CF Series Performance Curve 150x125-315

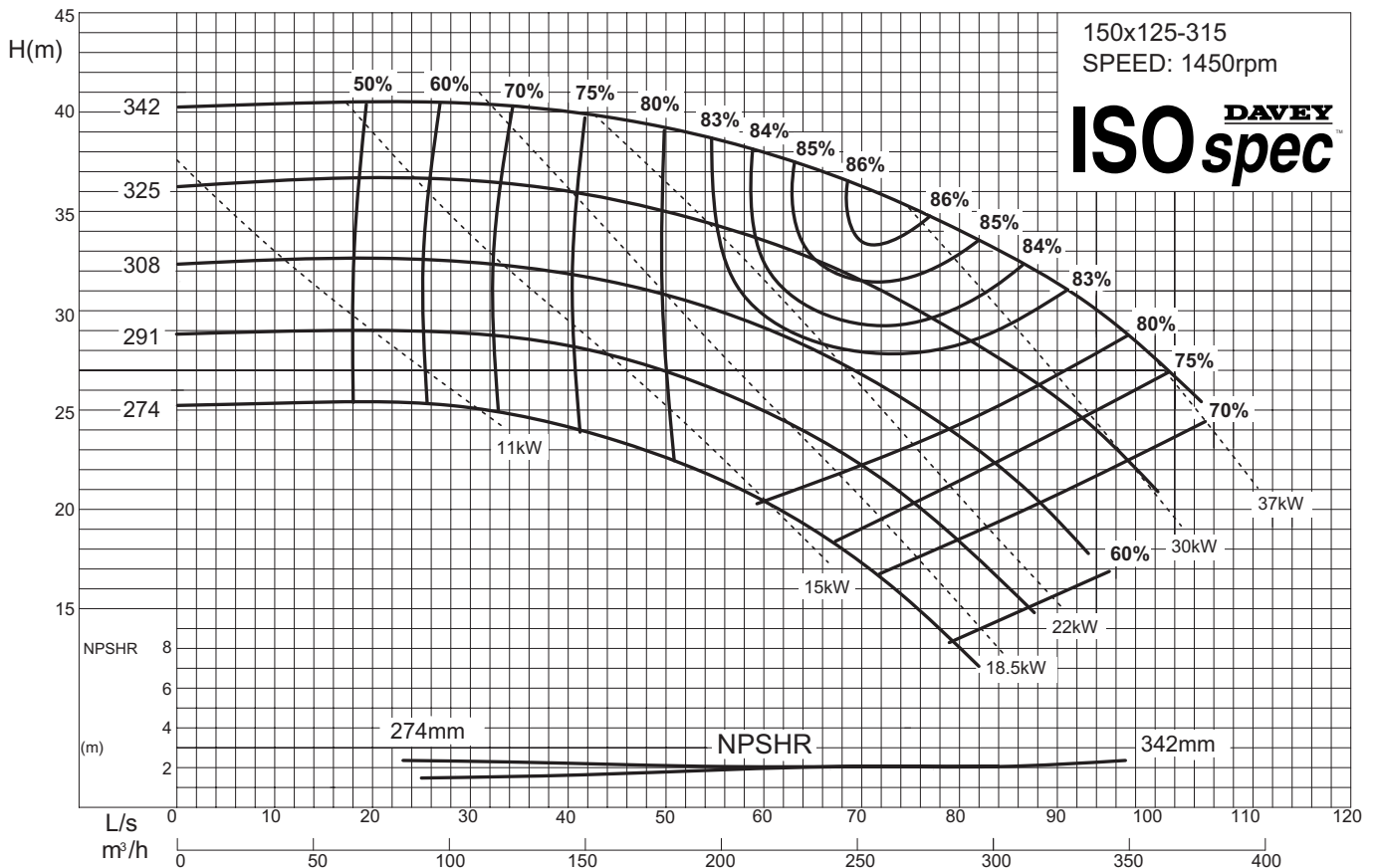

TECHNICAL SPECIFICATIONS

ISOspec DAVEY®

CF Series Performance Curve 150x125-400

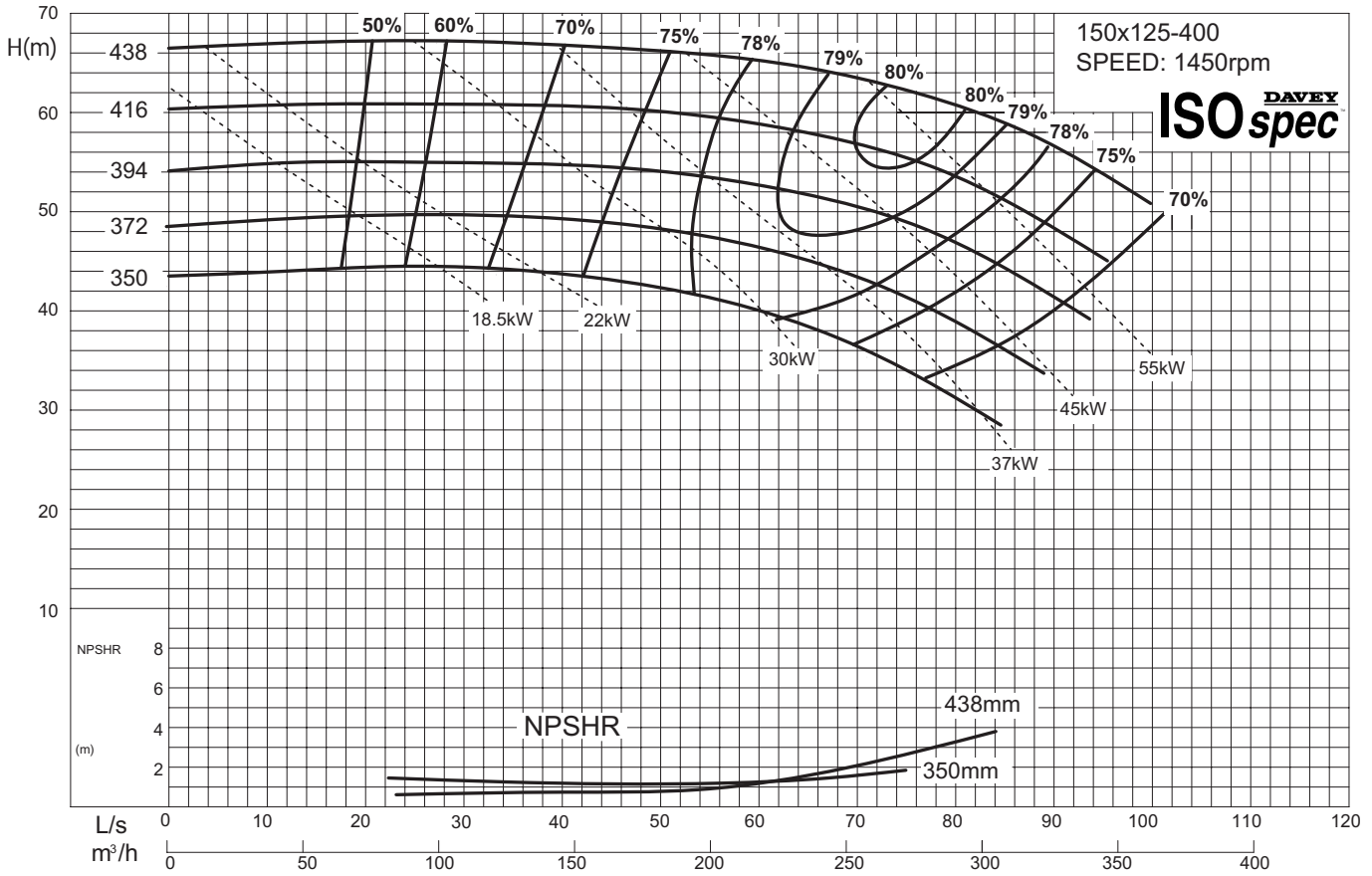

CF Series Performance Curve 150x125-500

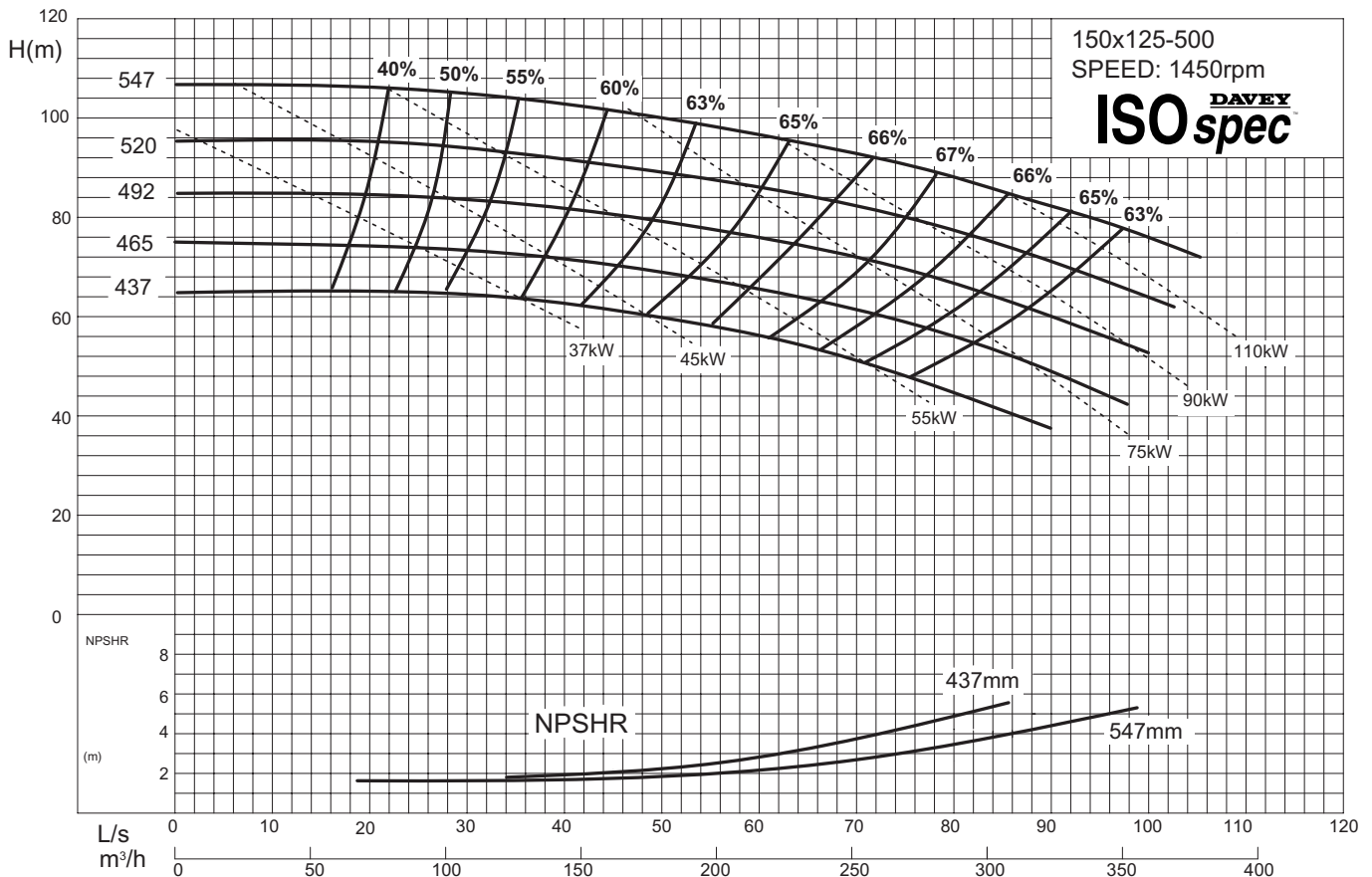

TECHNICAL SPECIFICATIONS

ISOspec DAVEY®

CF Series Performance Curve 200x150-315

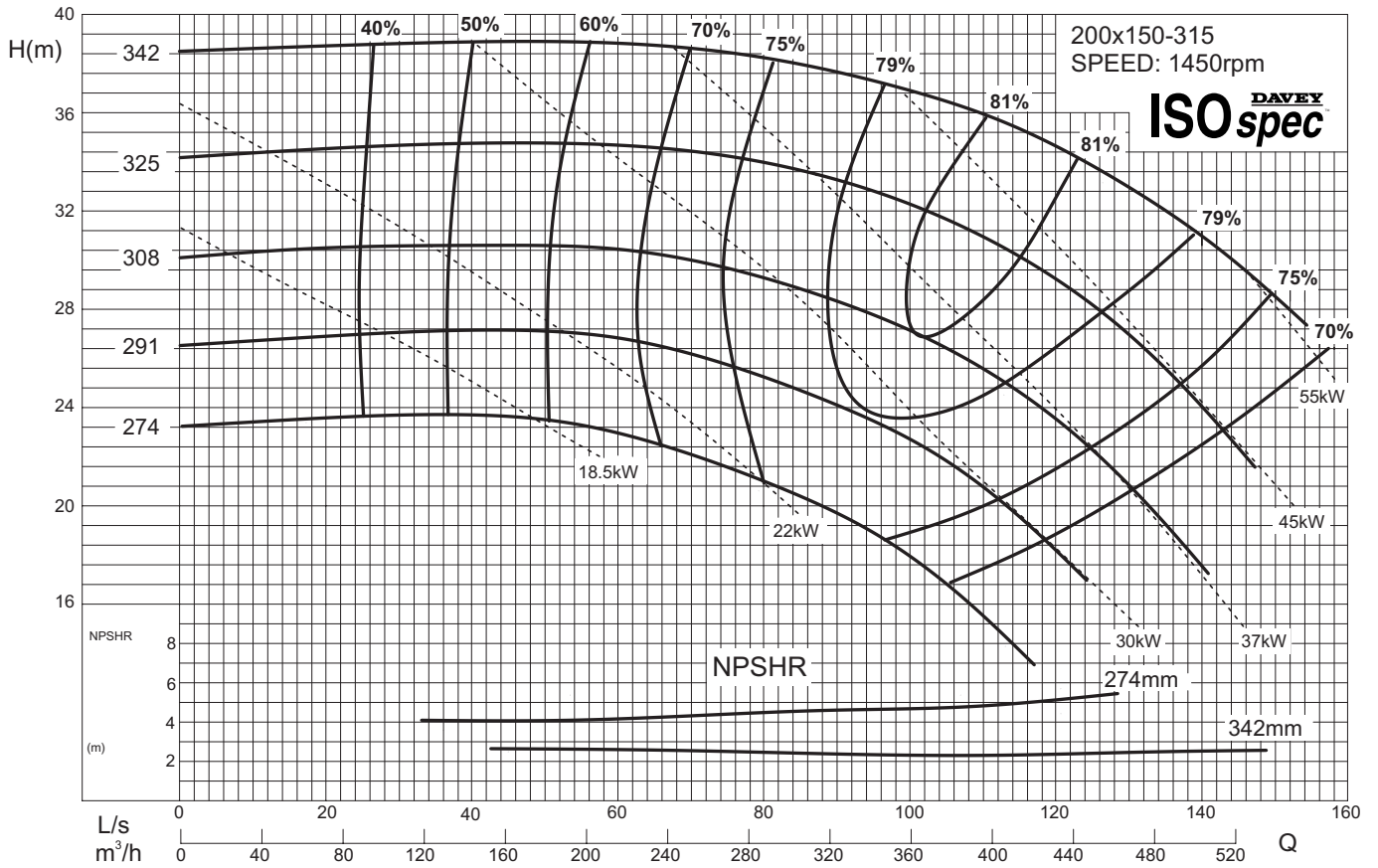

CF Series Performance Curve 200x150-400

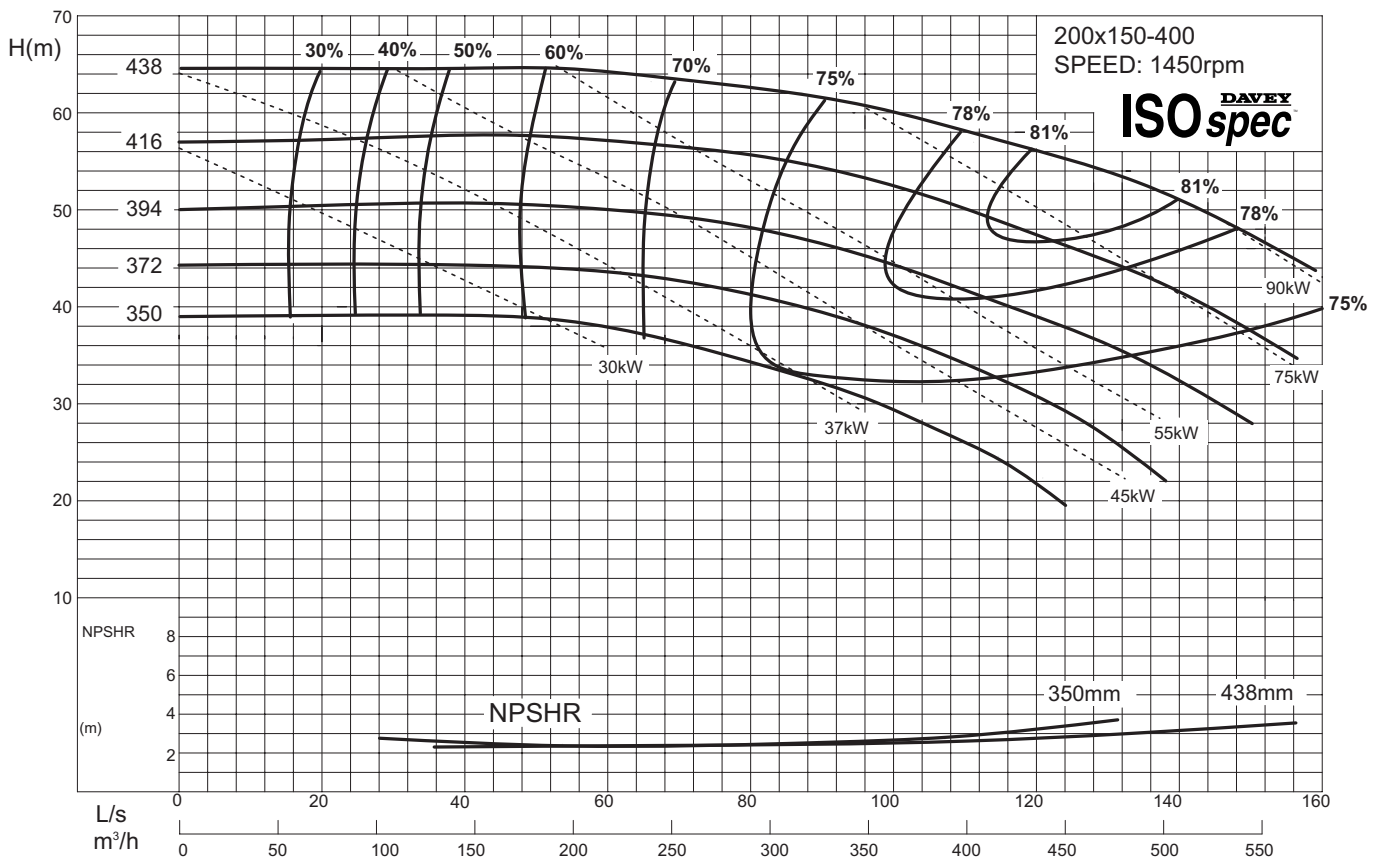

TECHNICAL SPECIFICATIONS

ISO spec DAVEY

CF Series Performance Curve 200x150-500

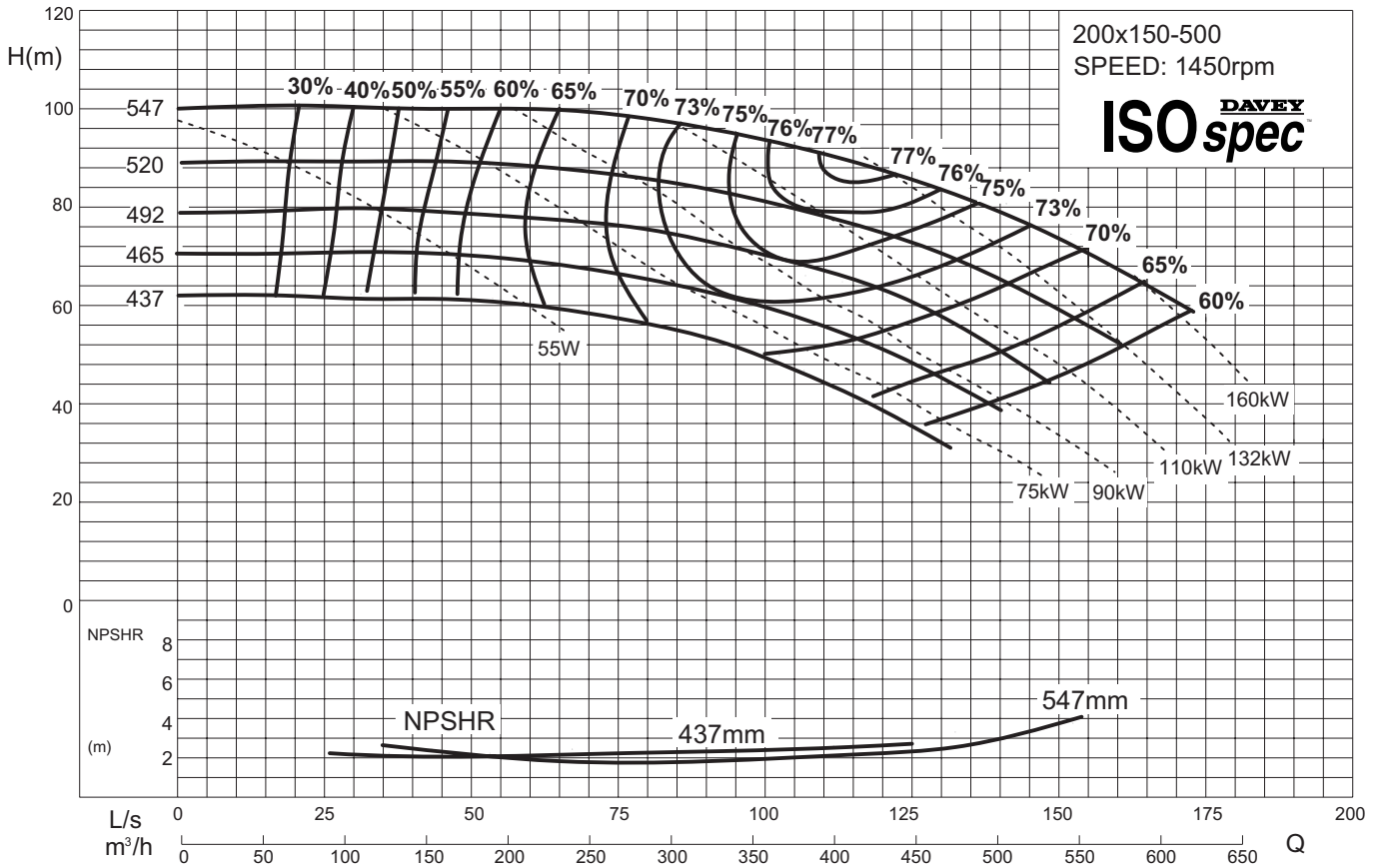

CF Series Performance Curve 250x200-315

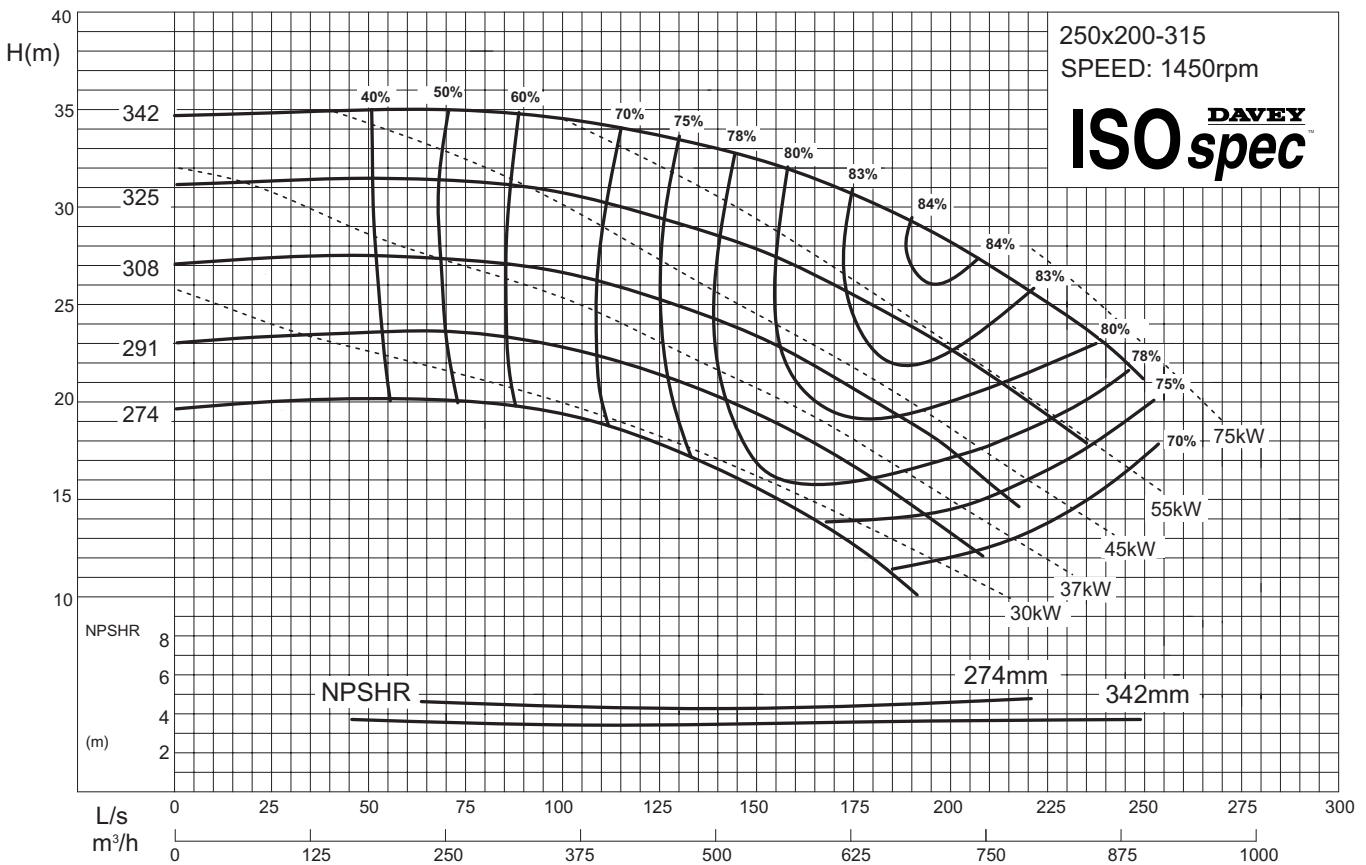

TECHNICAL SPECIFICATIONS

ISOspec DAVEY®

CF Series Performance Curve 250x200-400

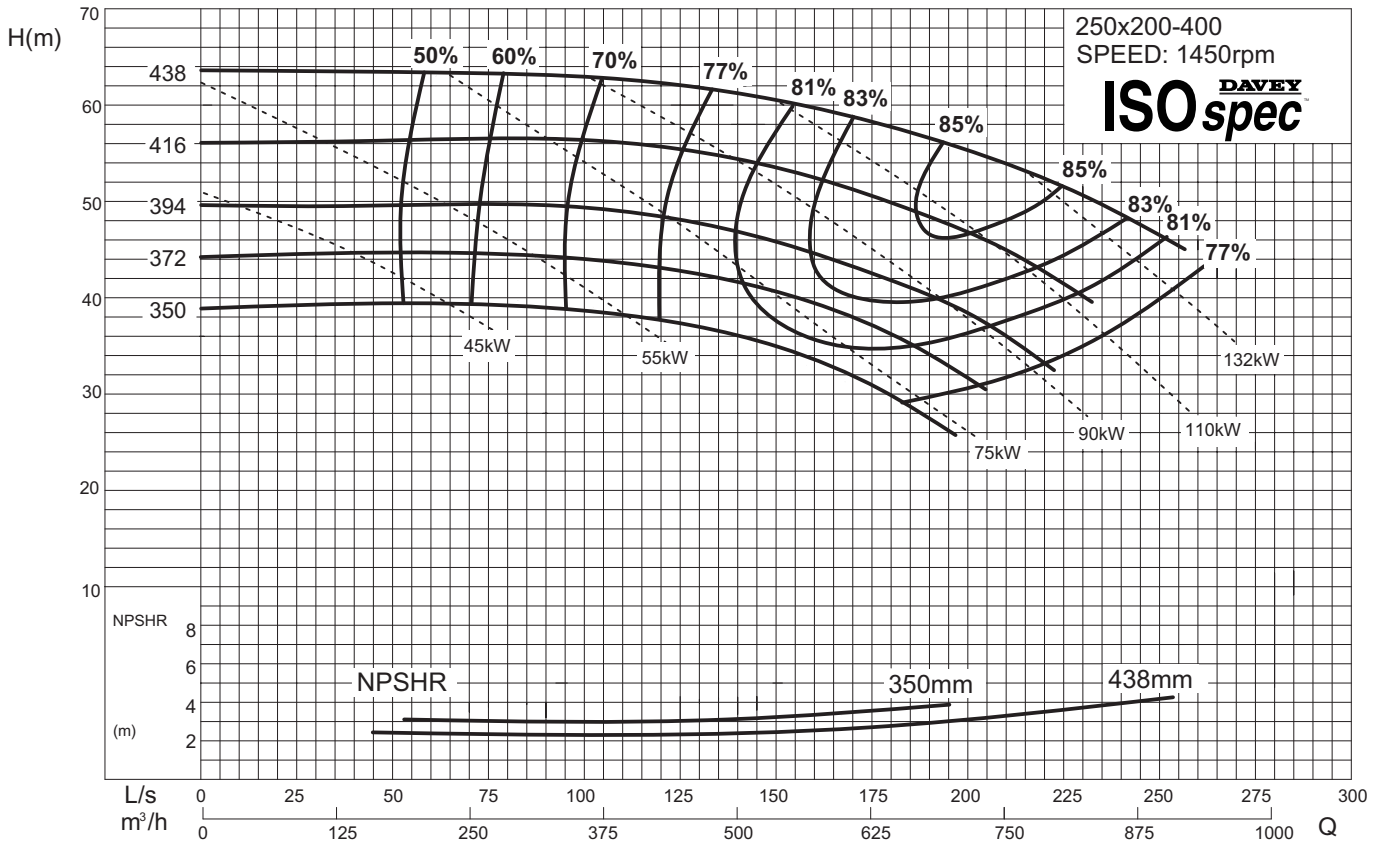

TECHNICAL SPECIFICATIONS



CF Series Variable Speed Performance Curve 50x32-160

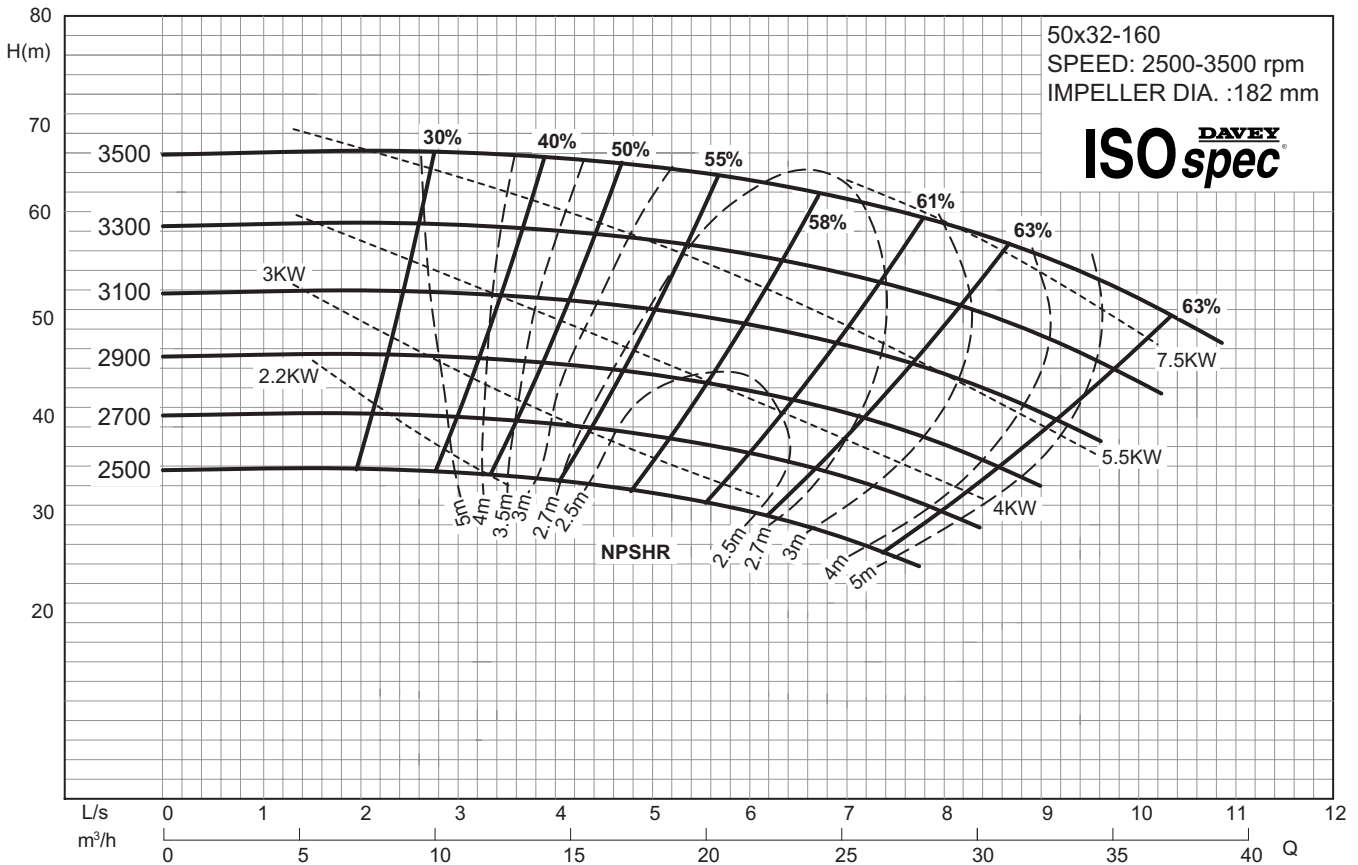
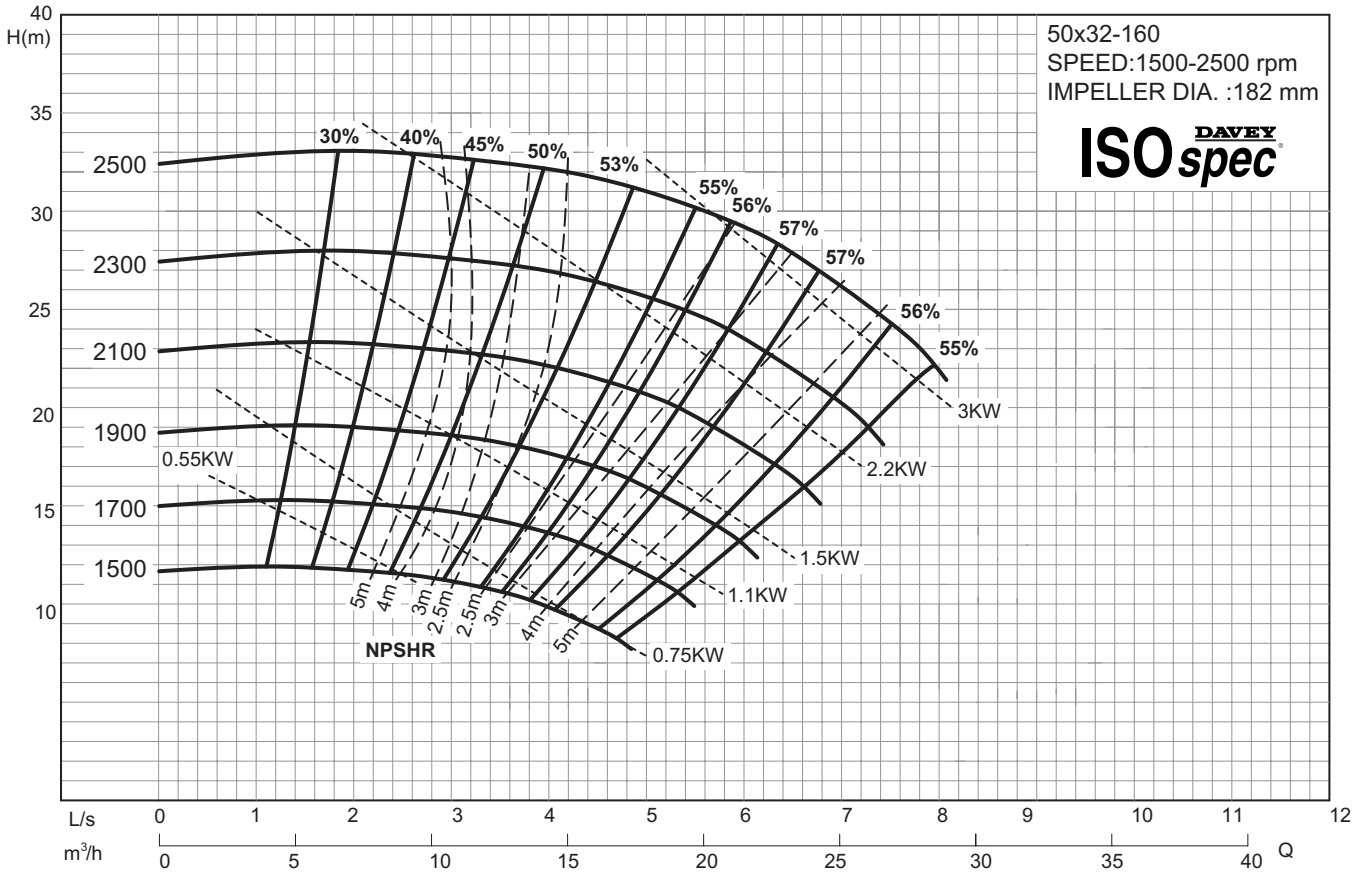

TECHNICAL SPECIFICATIONS



CF Series Variable Speed Performance Curve 50x32-200

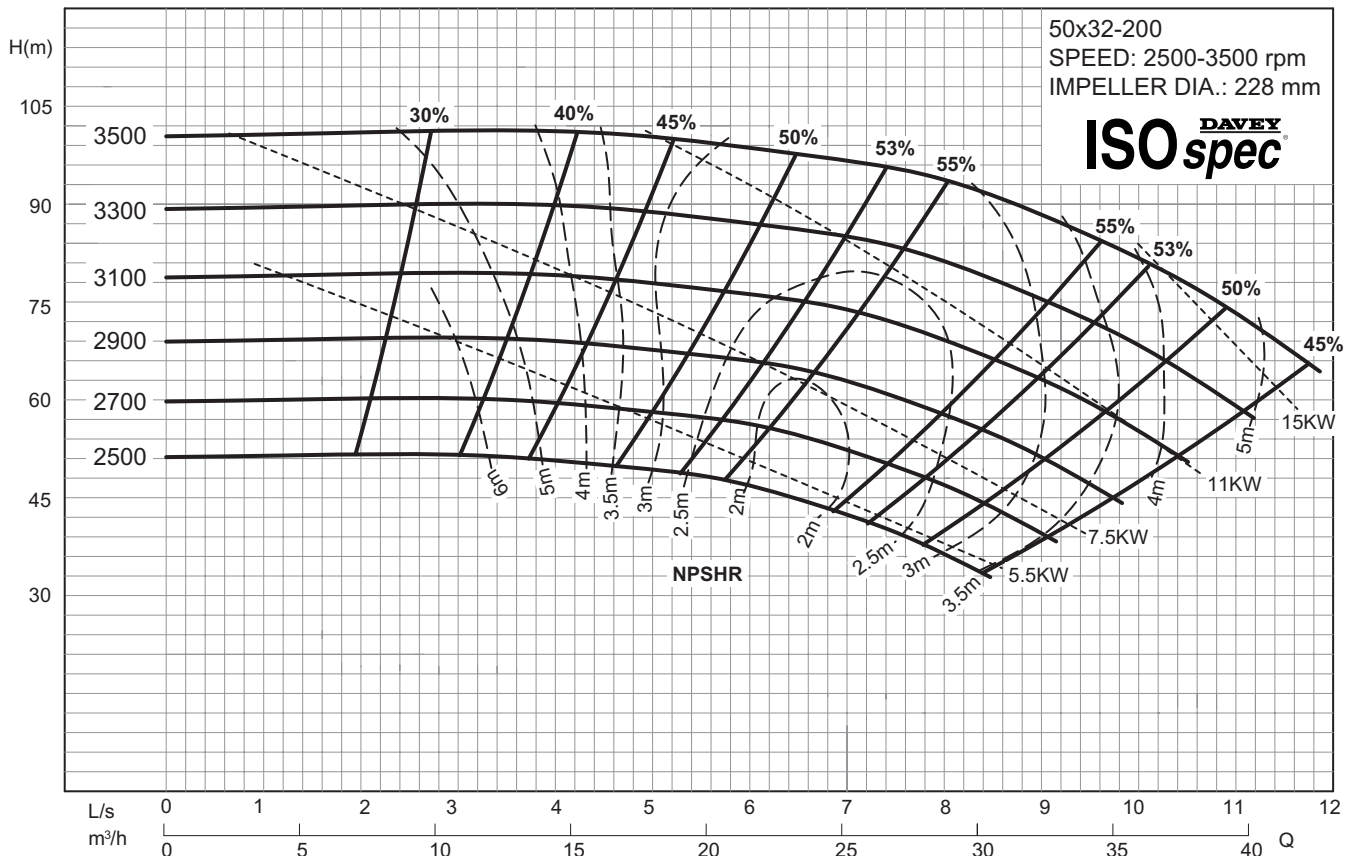
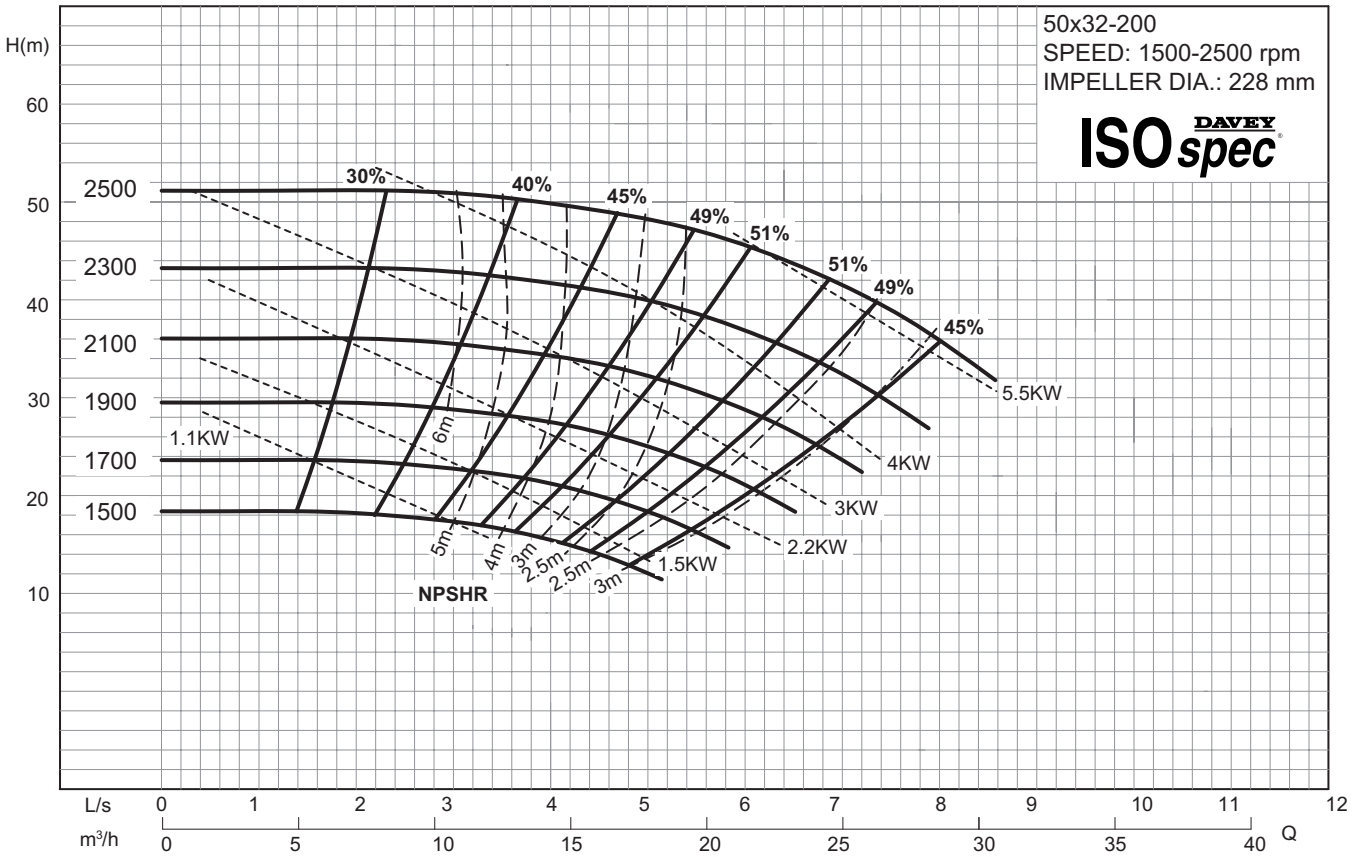

TECHNICAL SPECIFICATIONS

ISO spec DAVEY

CF Series Variable Speed Performance Curve 65x40-200

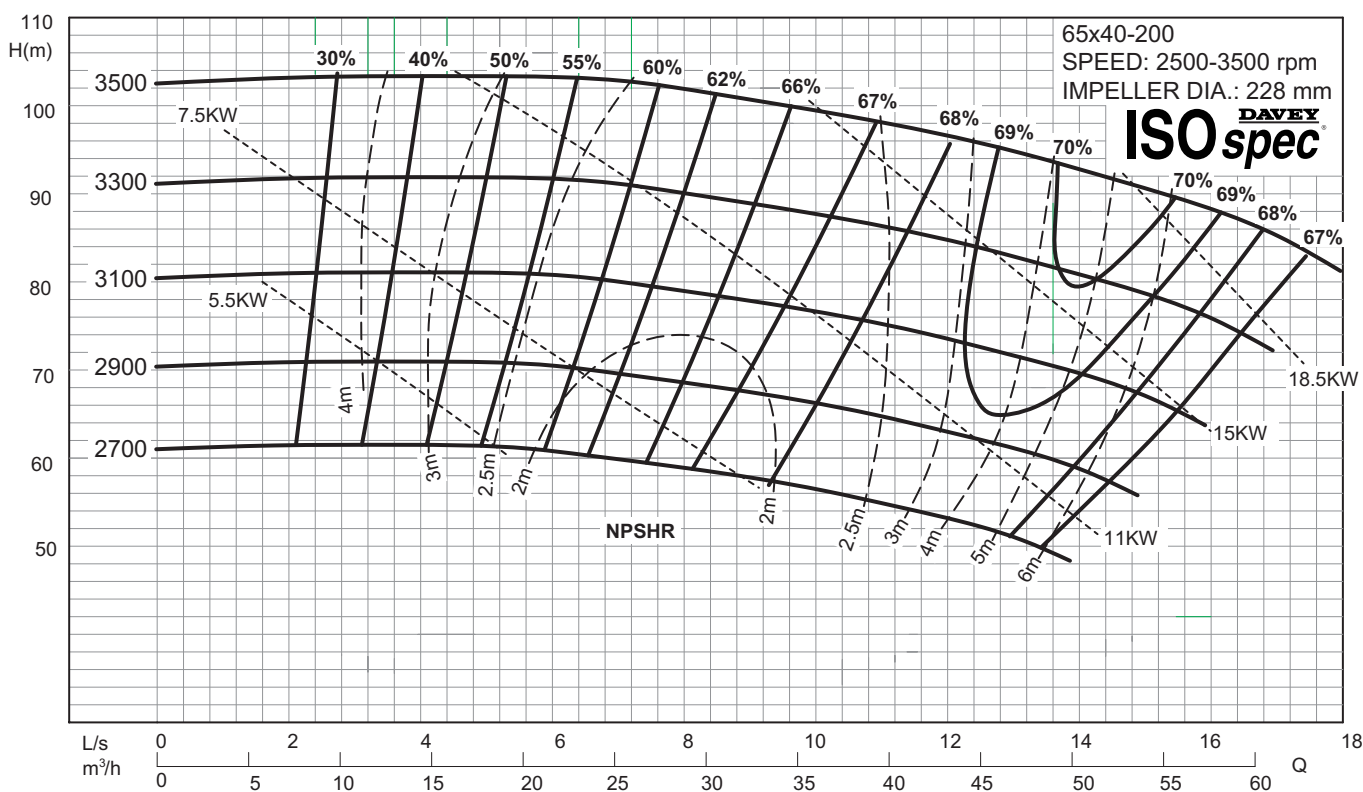
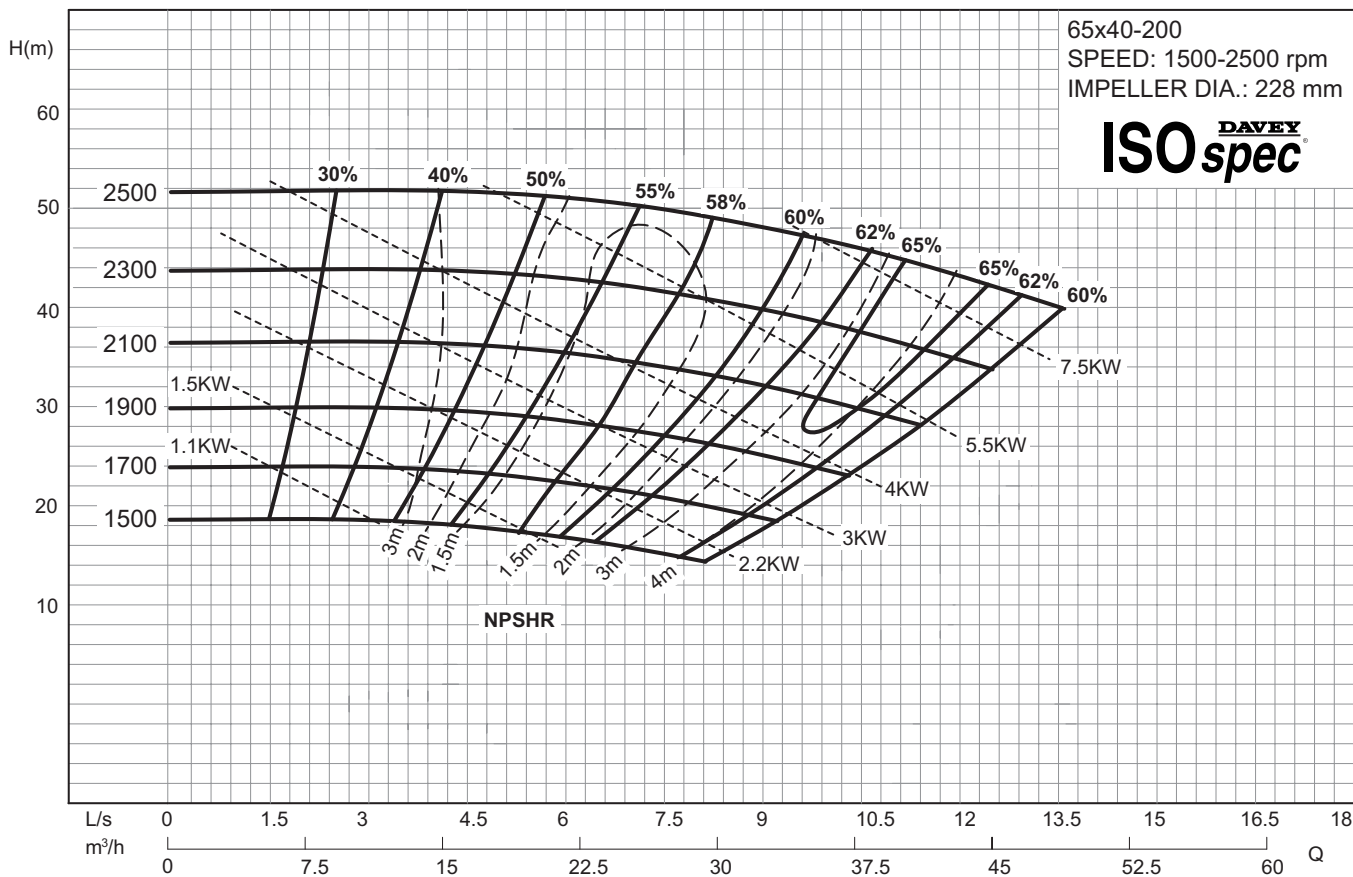

TECHNICAL SPECIFICATIONS

ISO spec[®]

CF Series Variable Speed Performance Curve 65x40-250

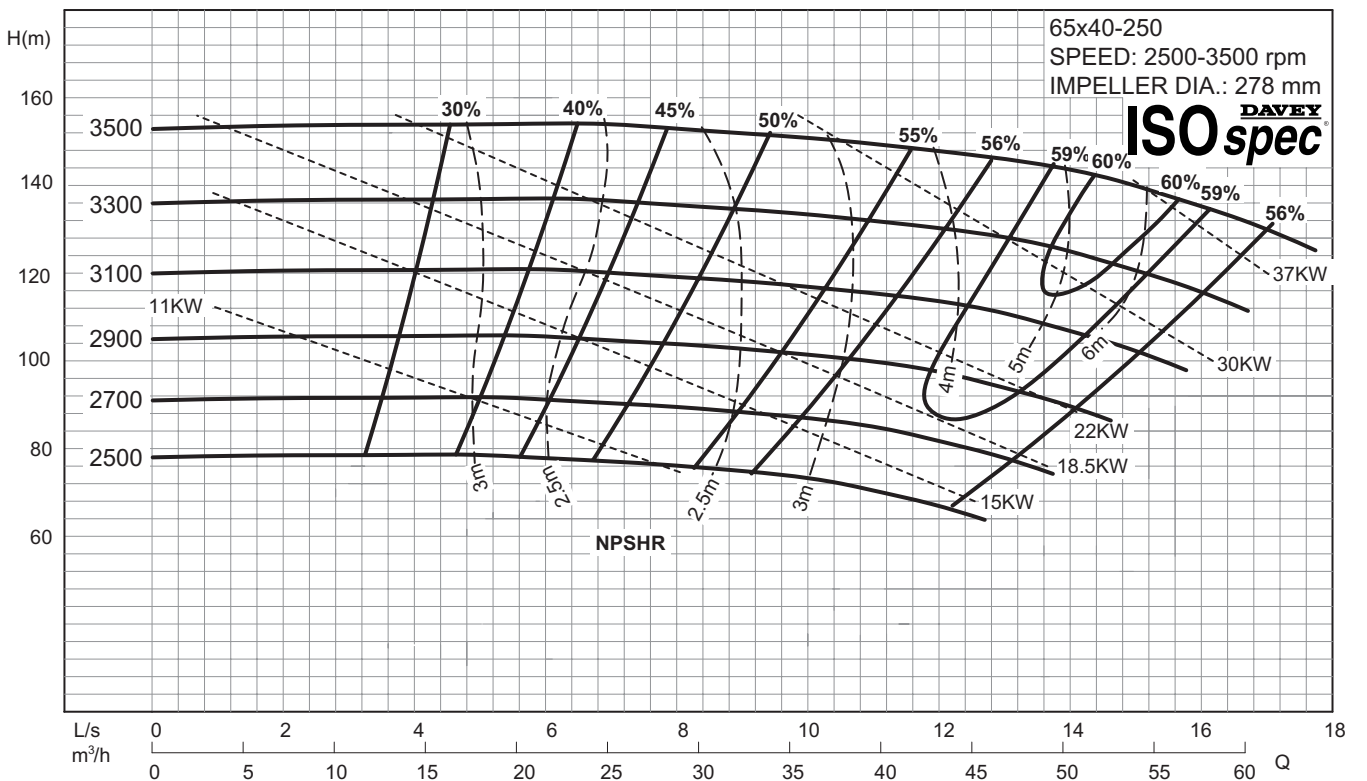
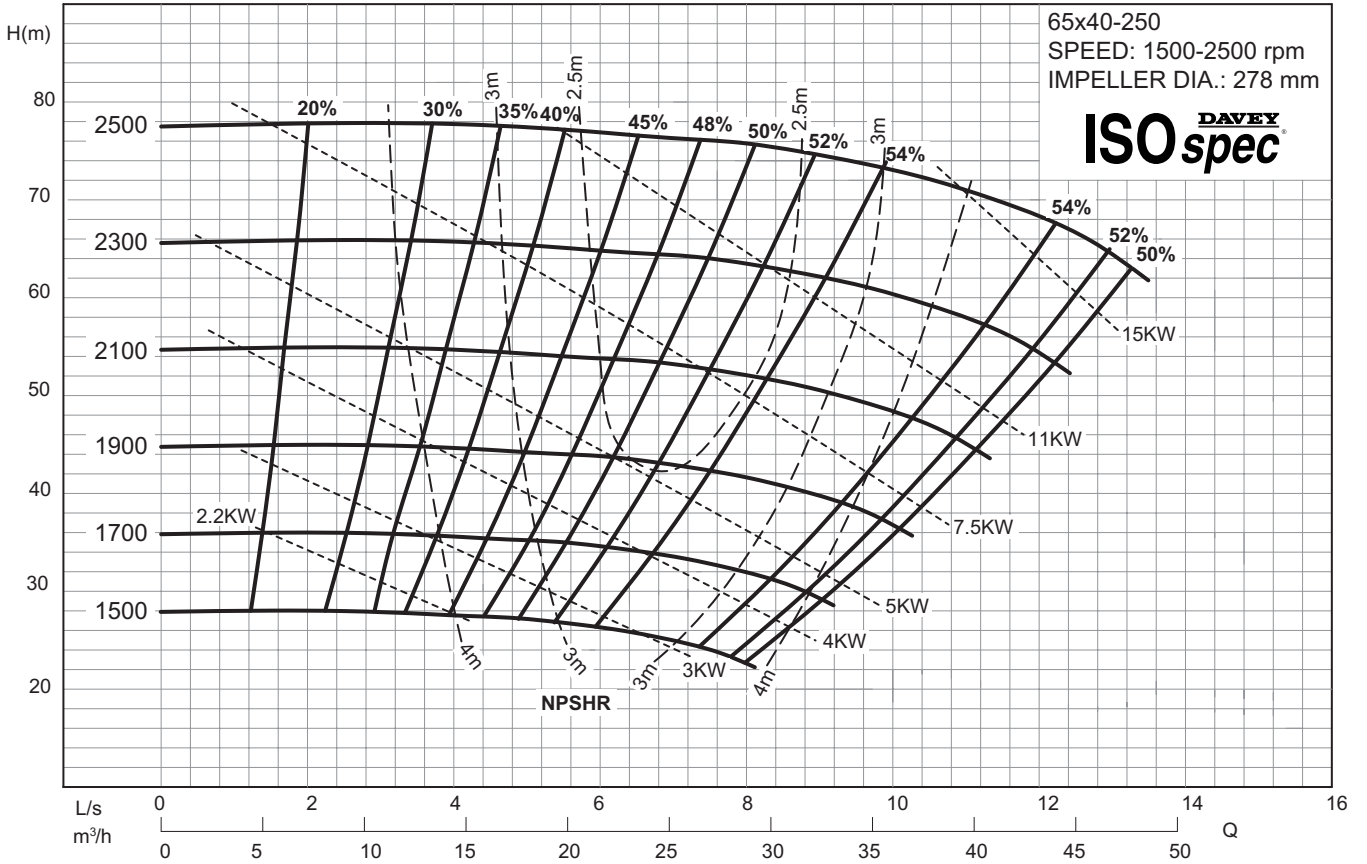

TECHNICAL SPECIFICATIONS

ISO spec DAVEY

CF Series Variable Speed Performance Curve 65x40-315

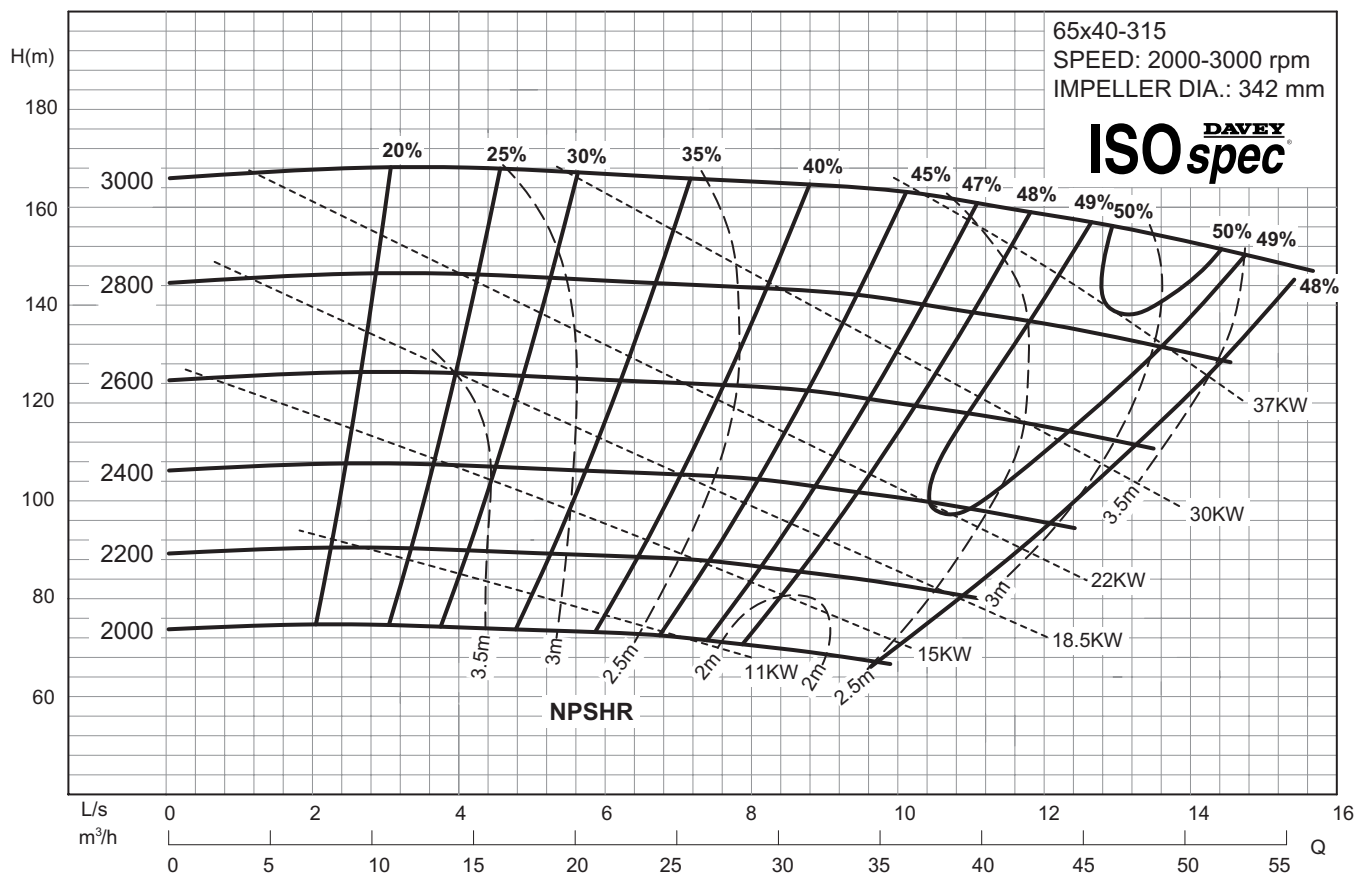
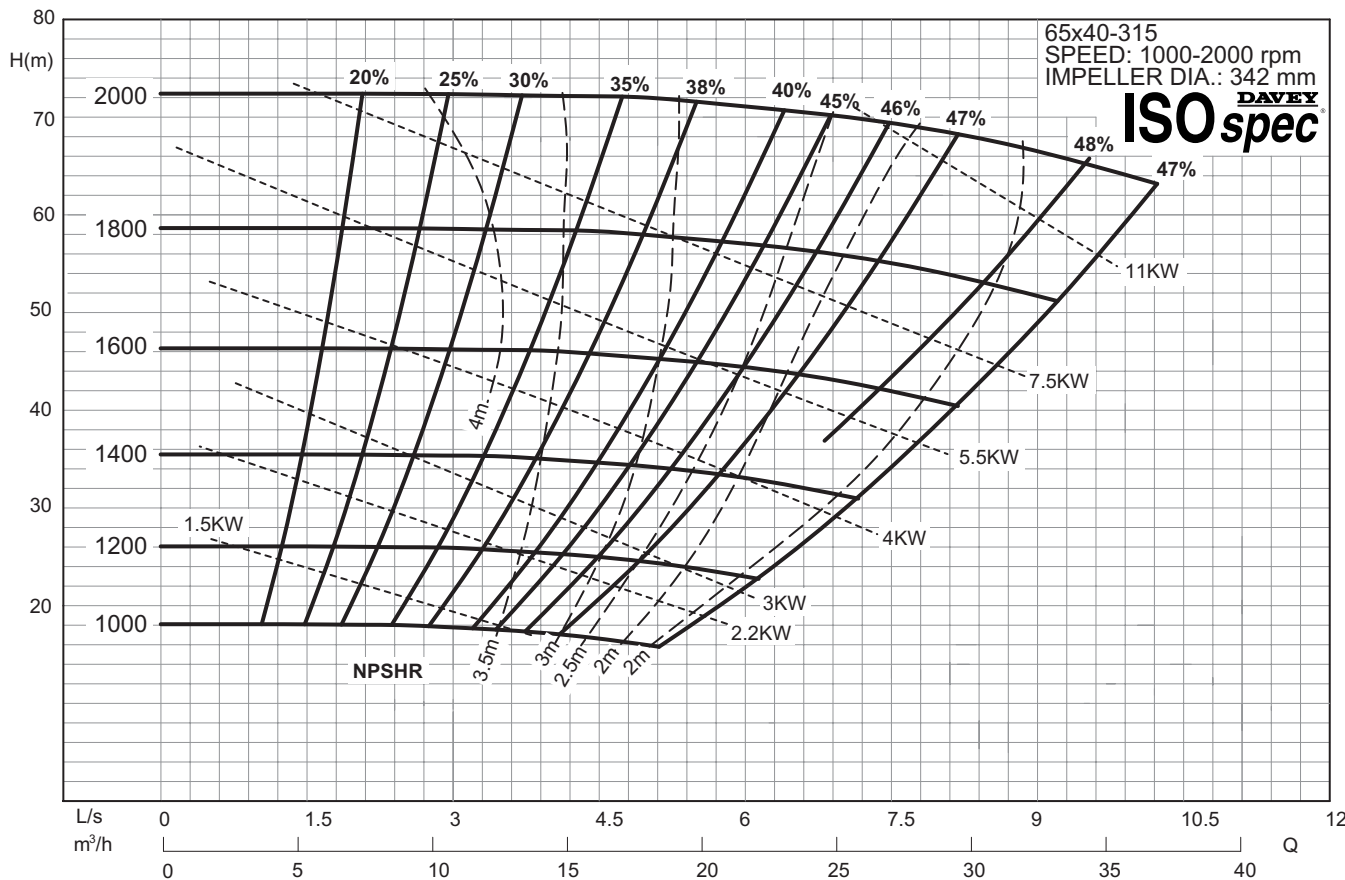

TECHNICAL SPECIFICATIONS

ISO spec DAVEY

CF Series Variable Speed Performance Curve 65x50-160

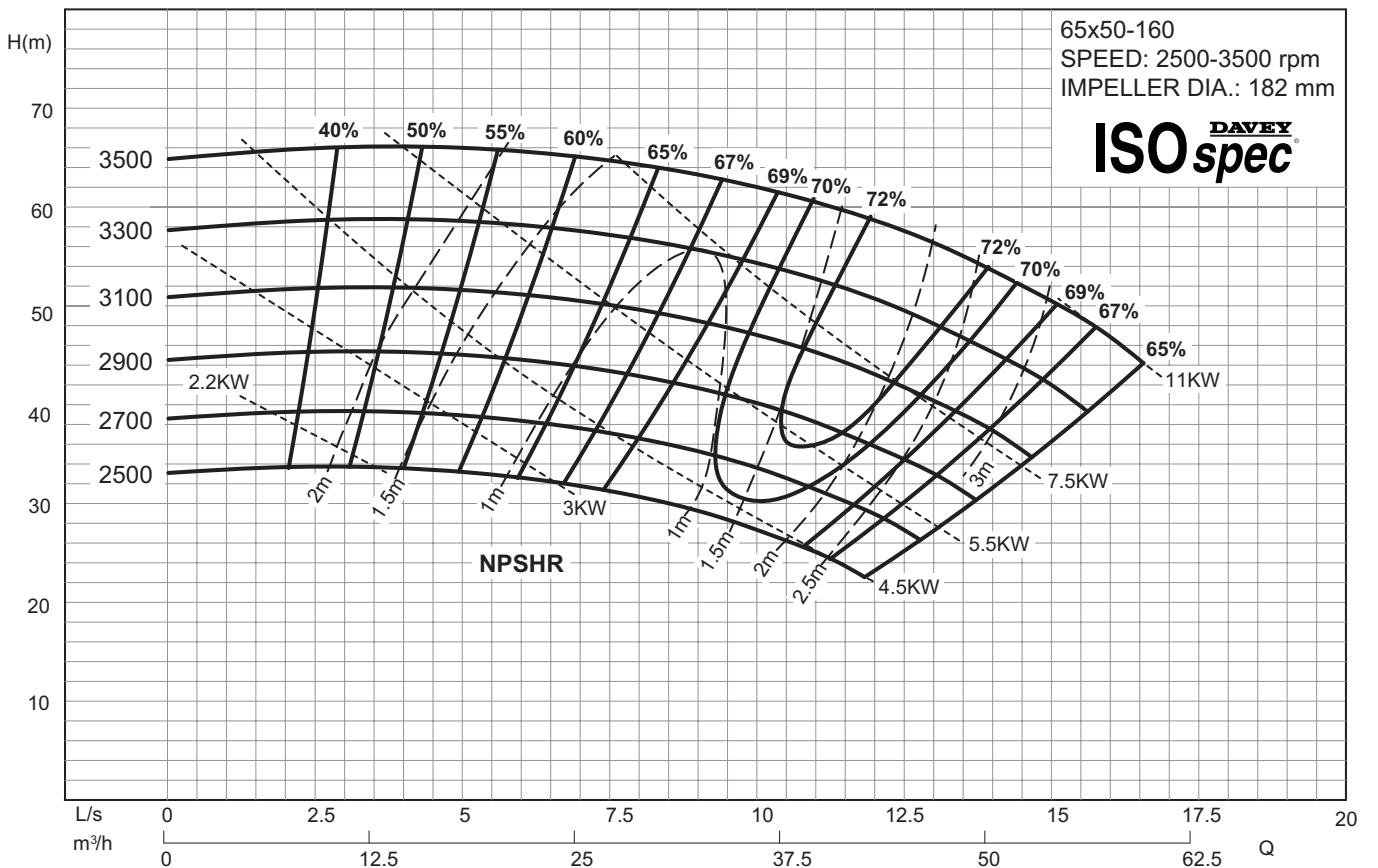
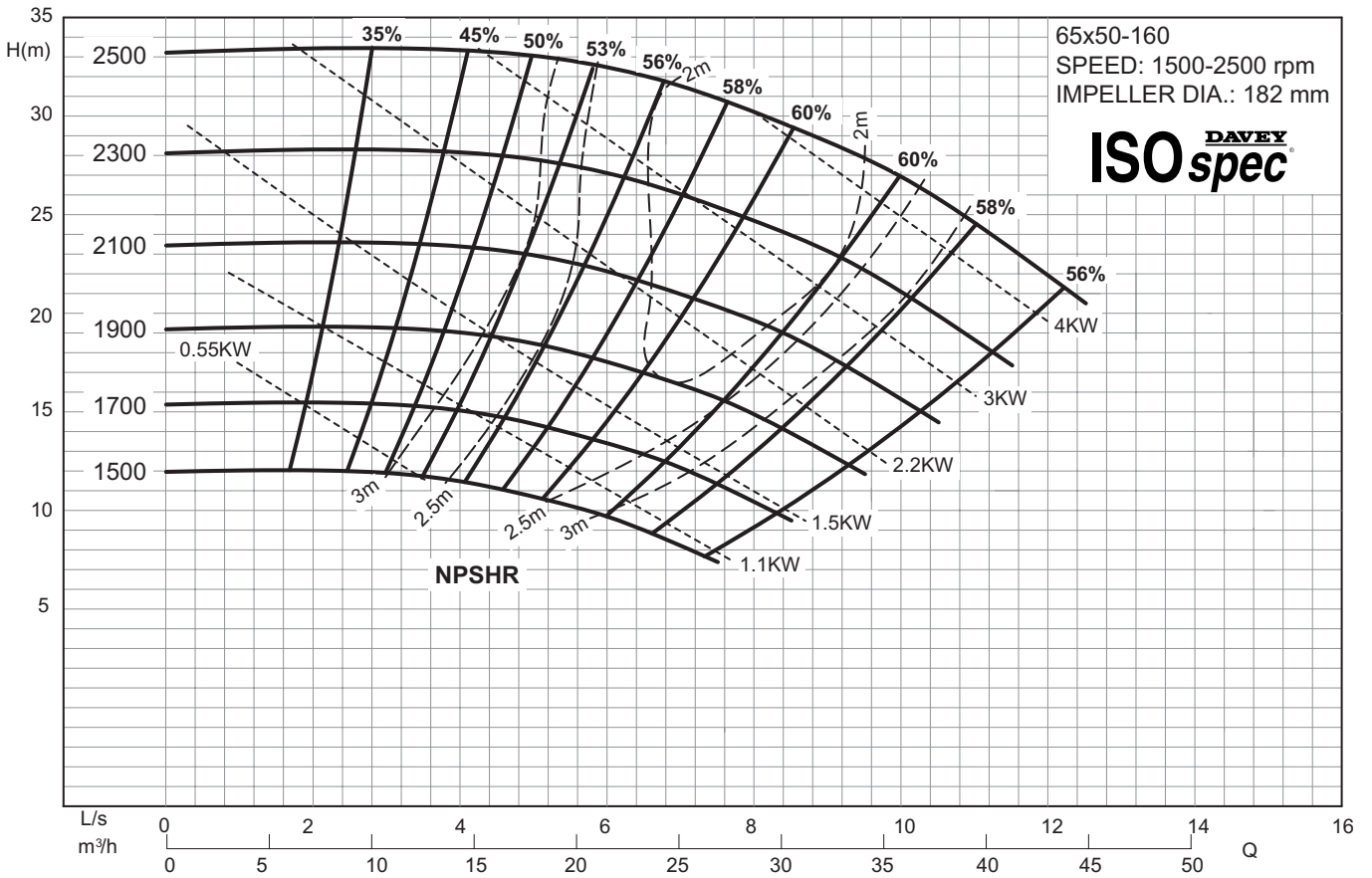

TECHNICAL SPECIFICATIONS

ISO spec DAVEY

CF Series Variable Speed Performance Curve 80x50-200

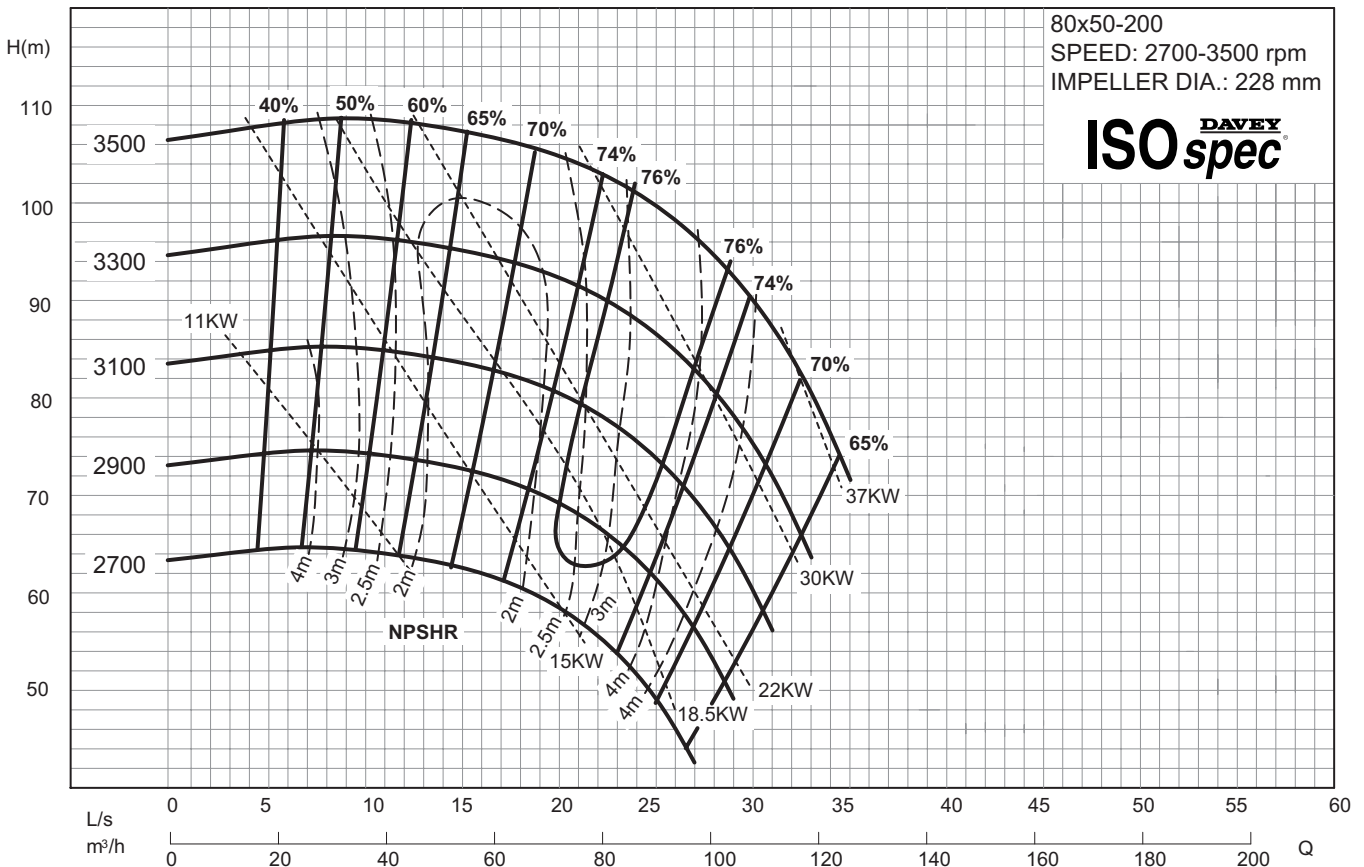
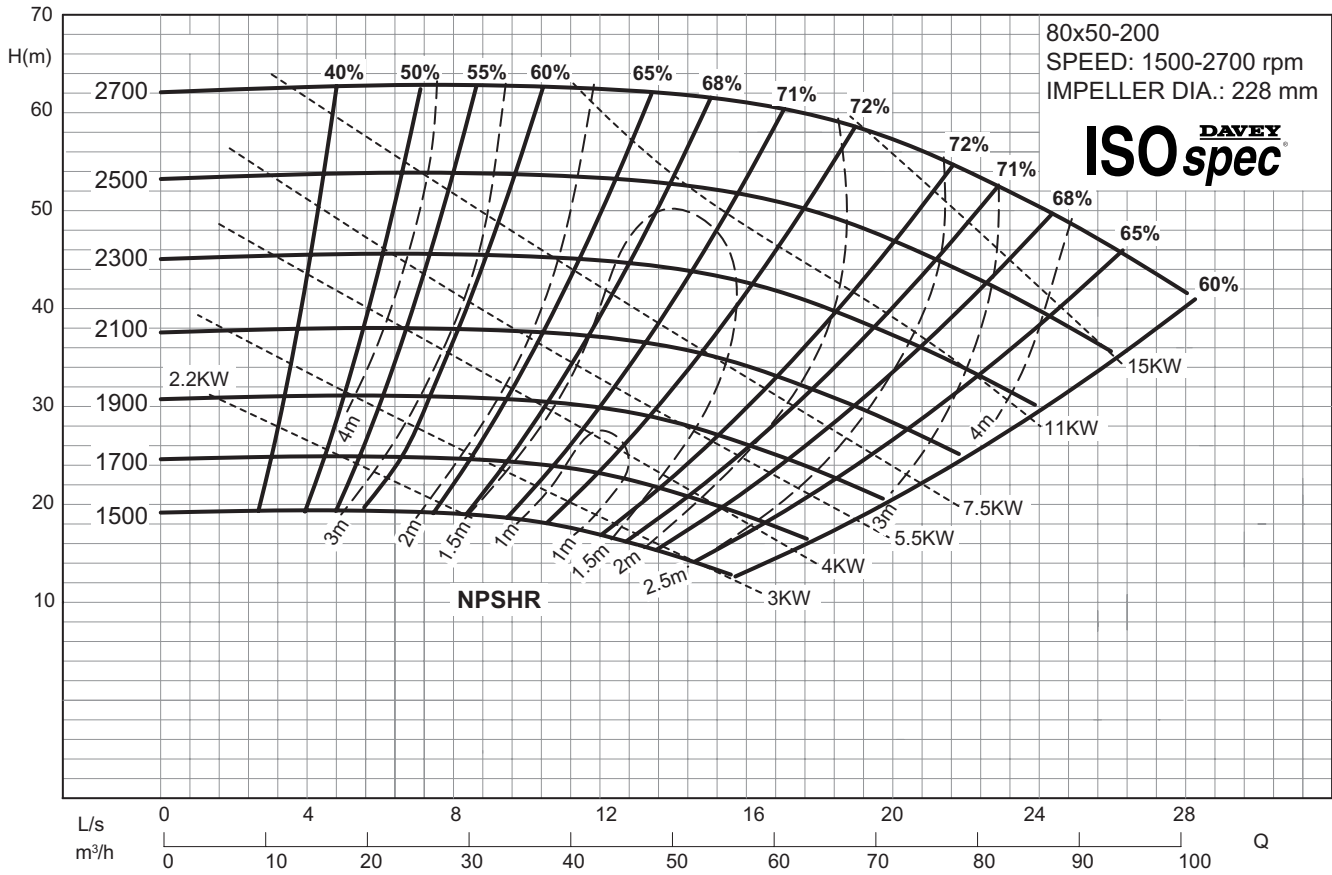

TECHNICAL SPECIFICATIONS

ISO spec DAVEY

CF Series Variable Speed Performance Curve 80x50-250

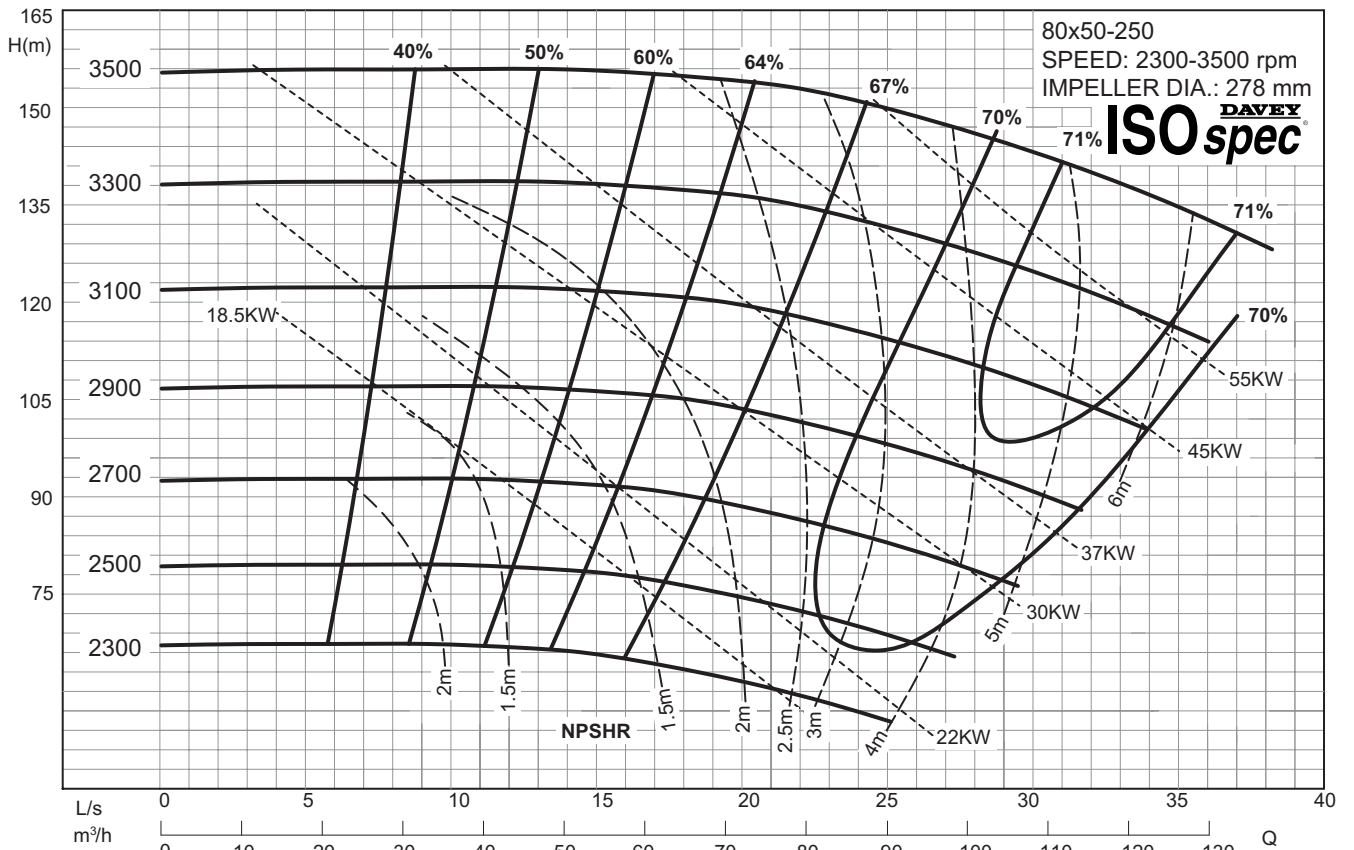
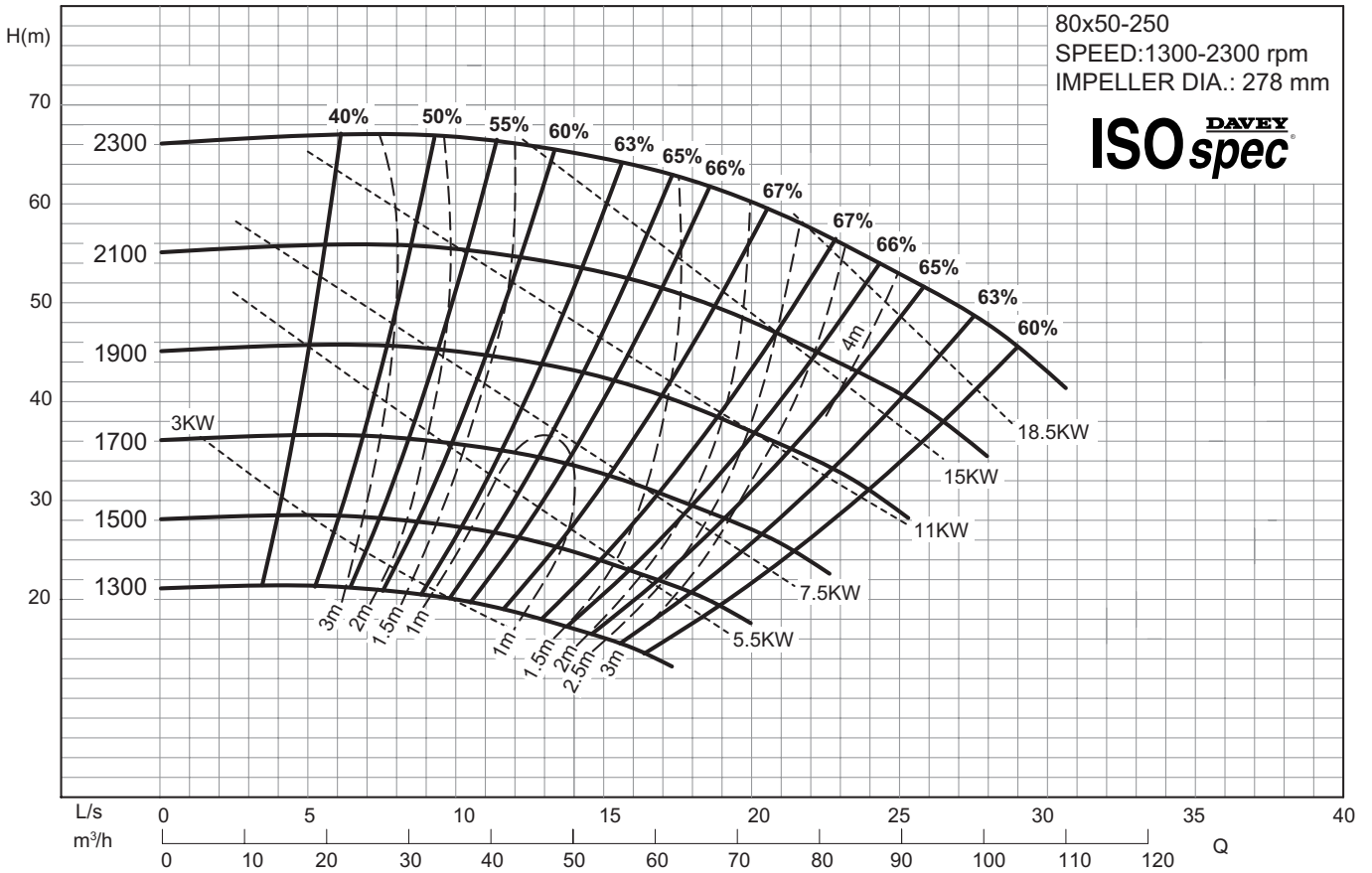

TECHNICAL SPECIFICATIONS

ISO spec ^{DAVEY}

CF Series Variable Speed Performance Curve 80x50-315

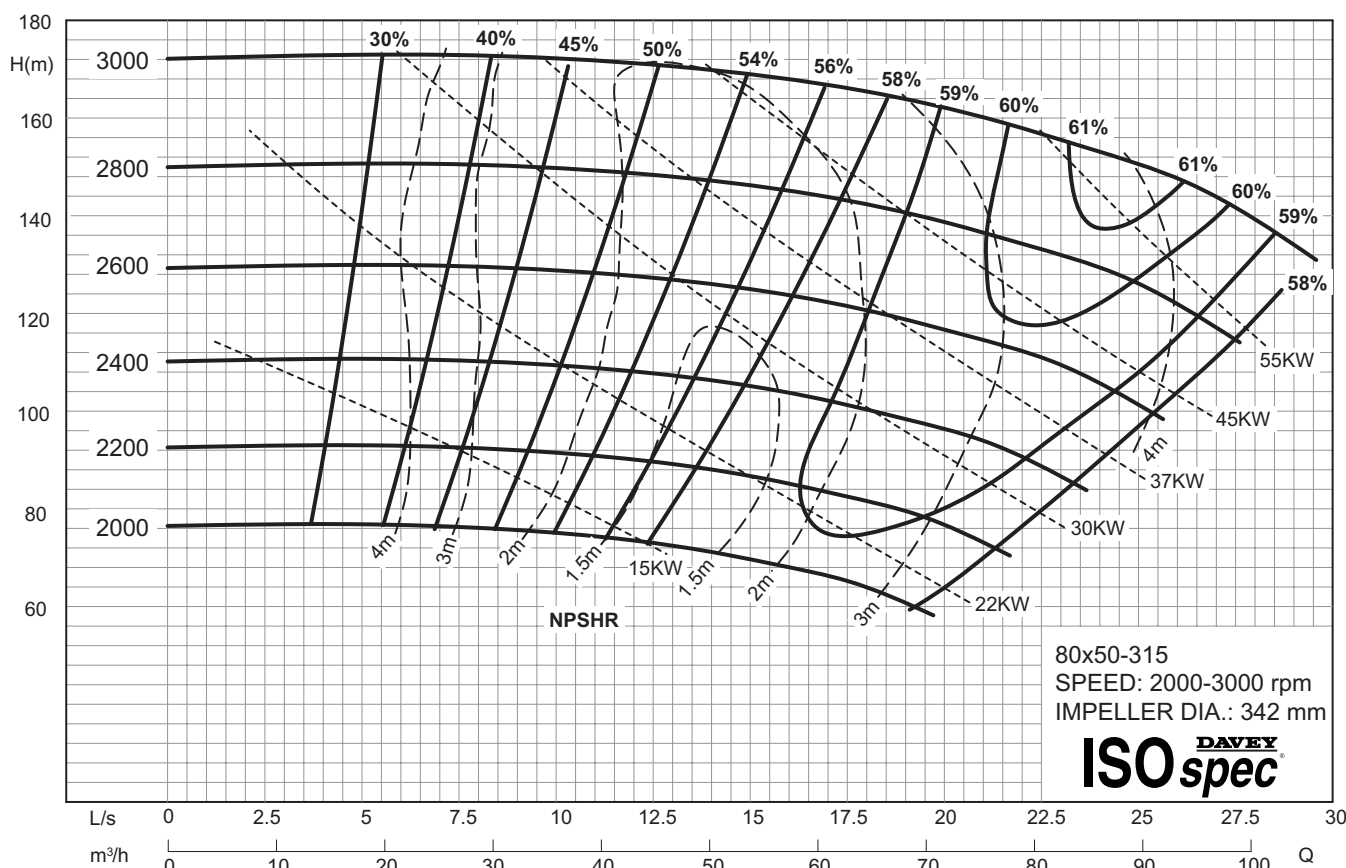
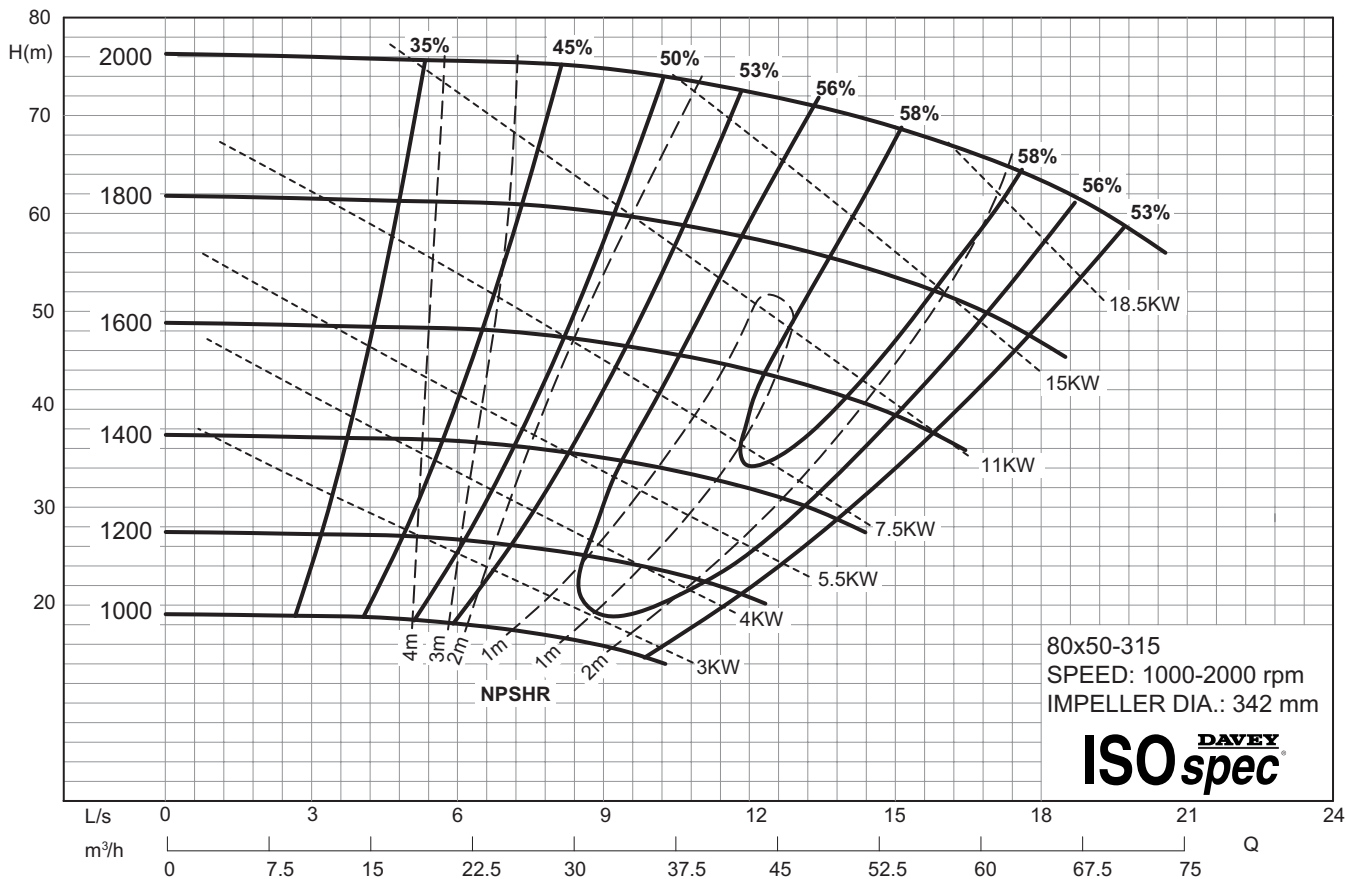

TECHNICAL SPECIFICATIONS

ISO spec DAVEY

CF Series Variable Speed Performance Curve 80x65-160

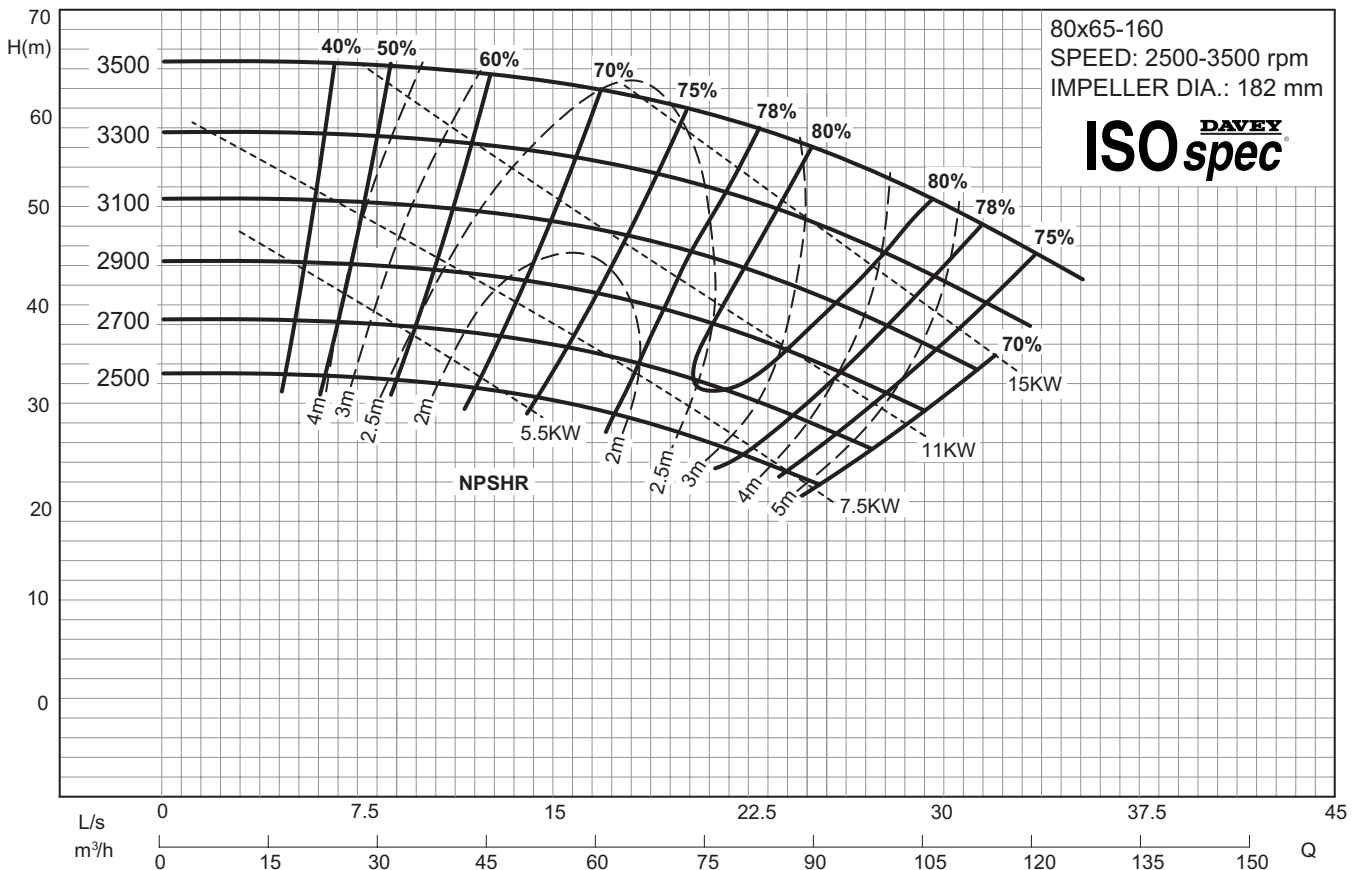
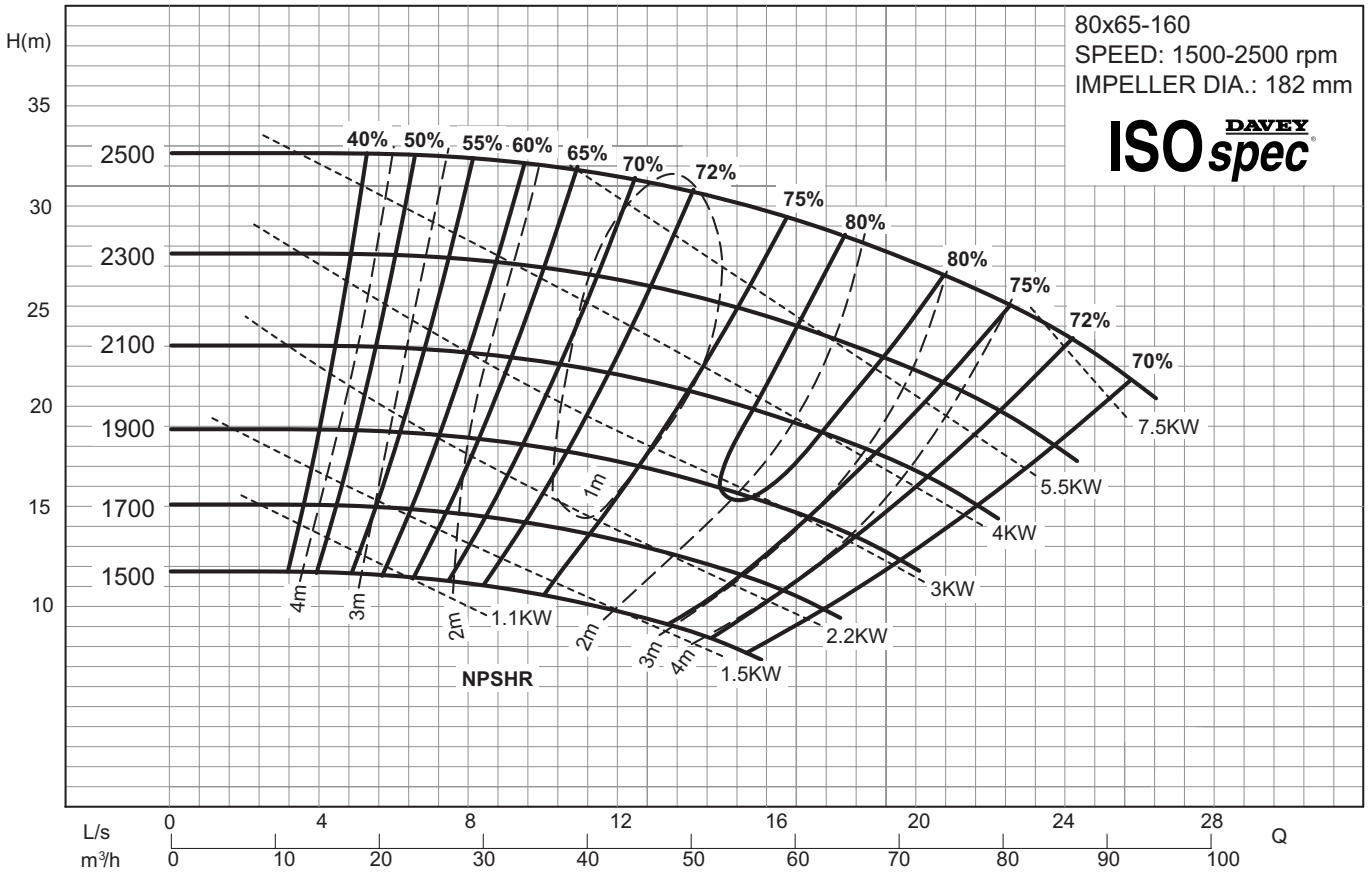

TECHNICAL SPECIFICATIONS

ISO spec ^{DAVEY}

CF Series Variable Speed Performance Curve 100x65-200

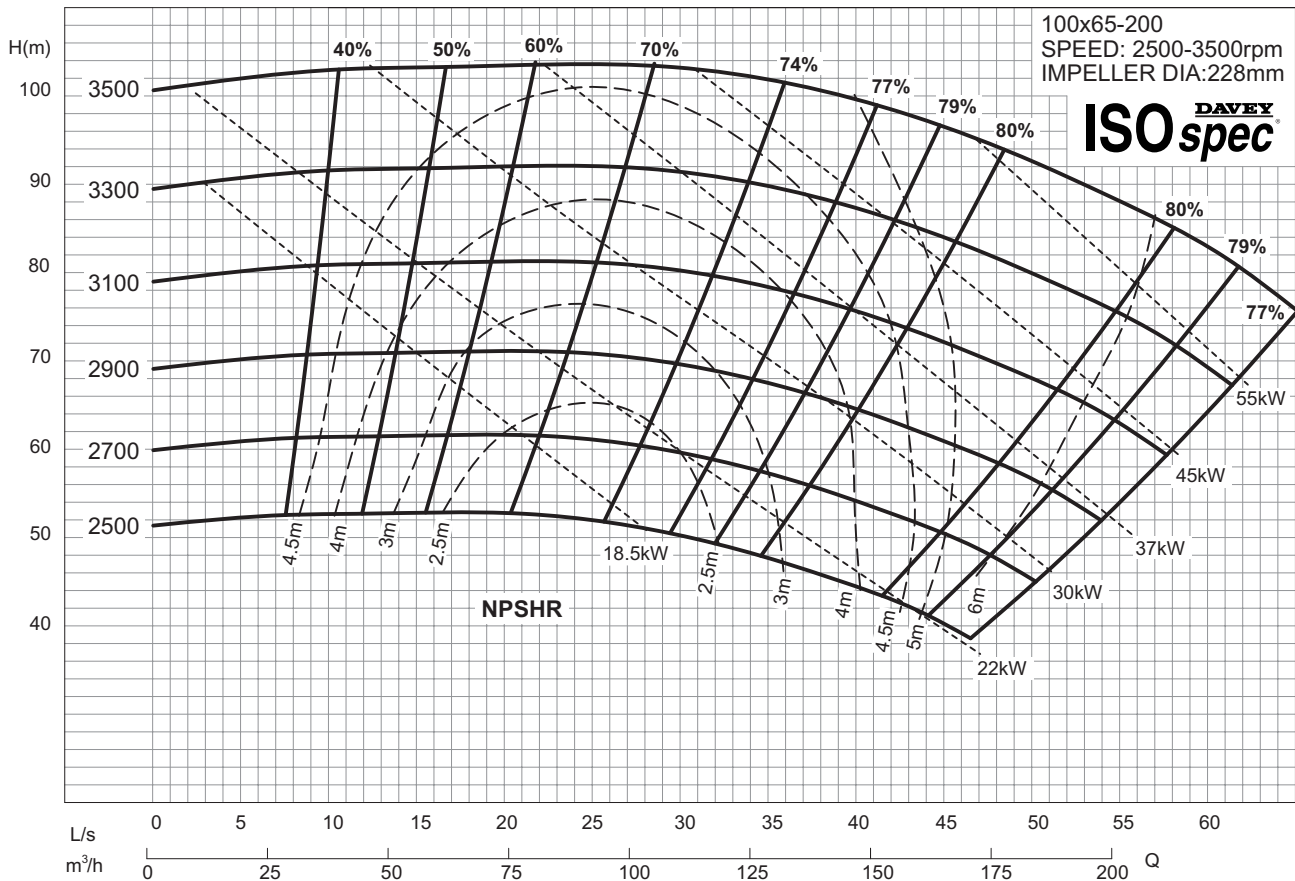
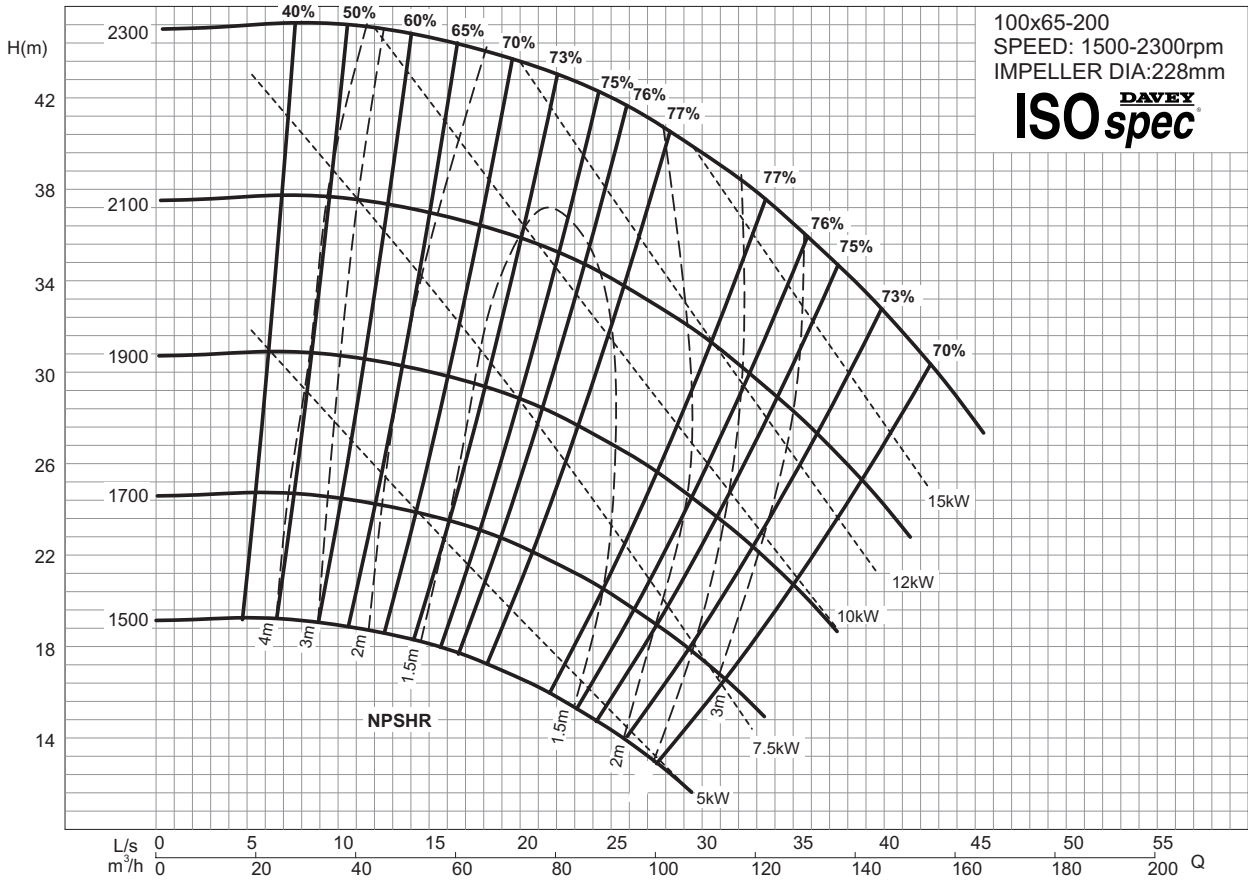

TECHNICAL SPECIFICATIONS

ISO spec ^{DAVEY}

CF Series Variable Speed Performance Curve 100x65-250

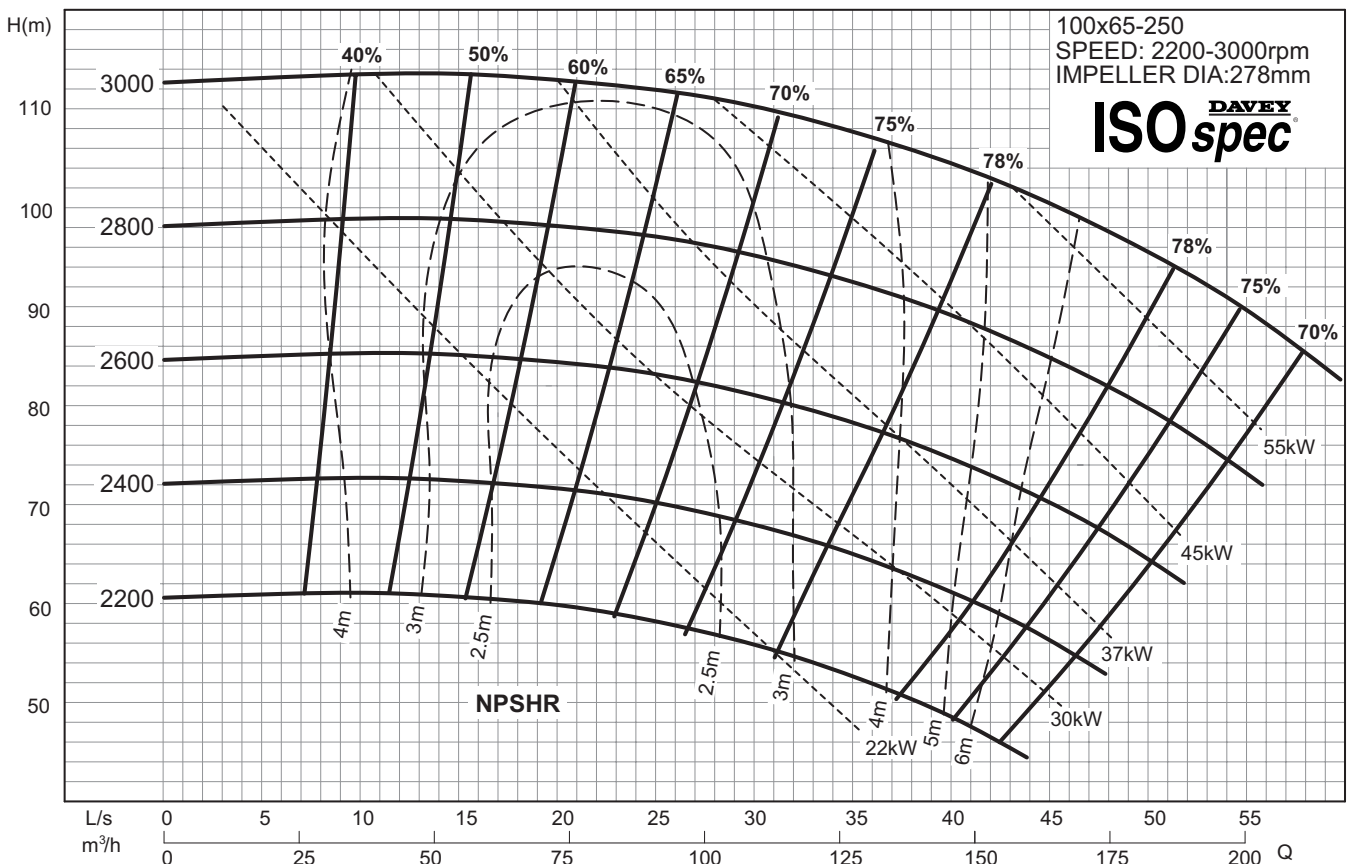
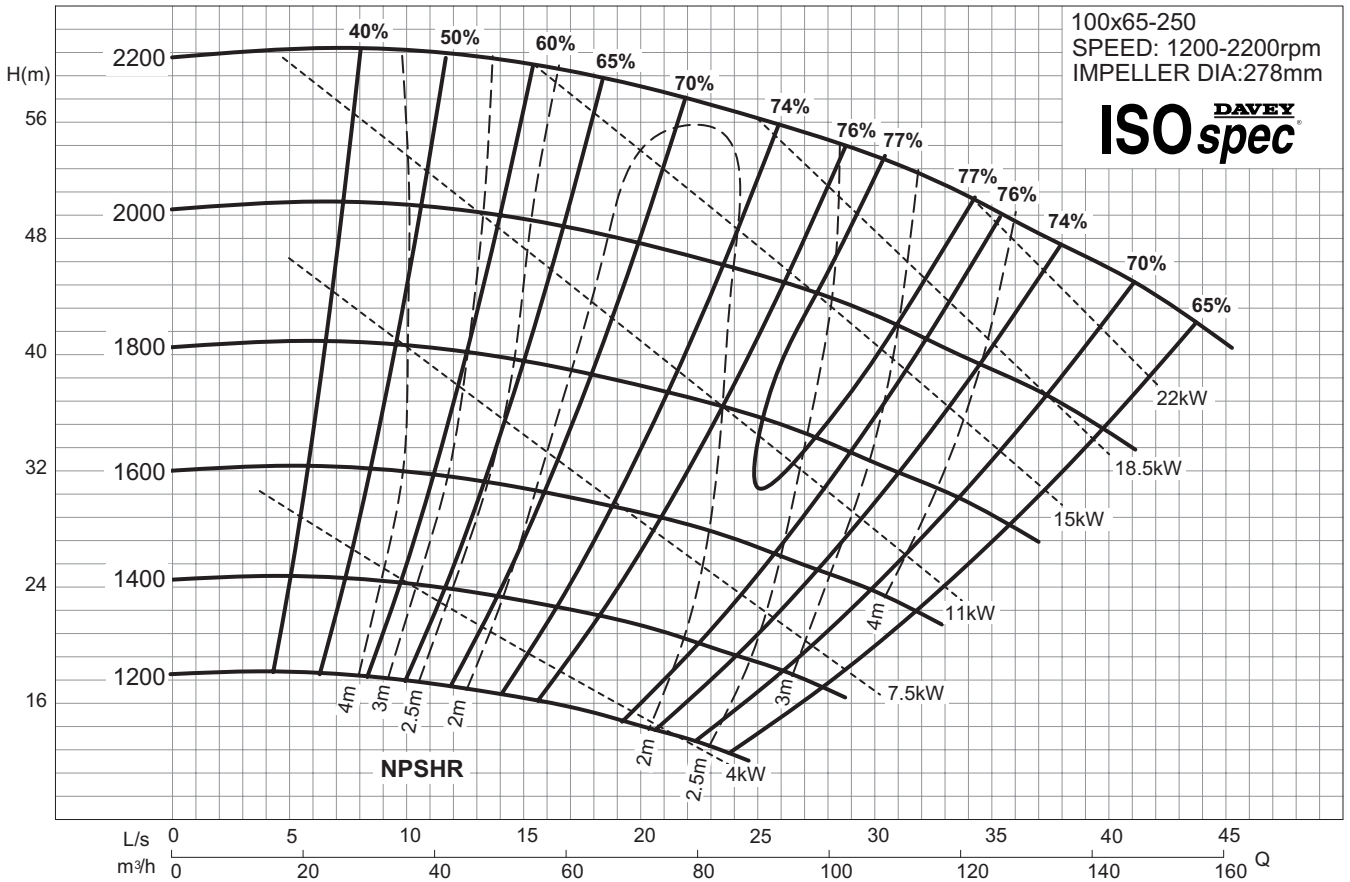

TECHNICAL SPECIFICATIONS

ISOspec[®]

CF Series Variable Speed Performance Curve 100x65-315

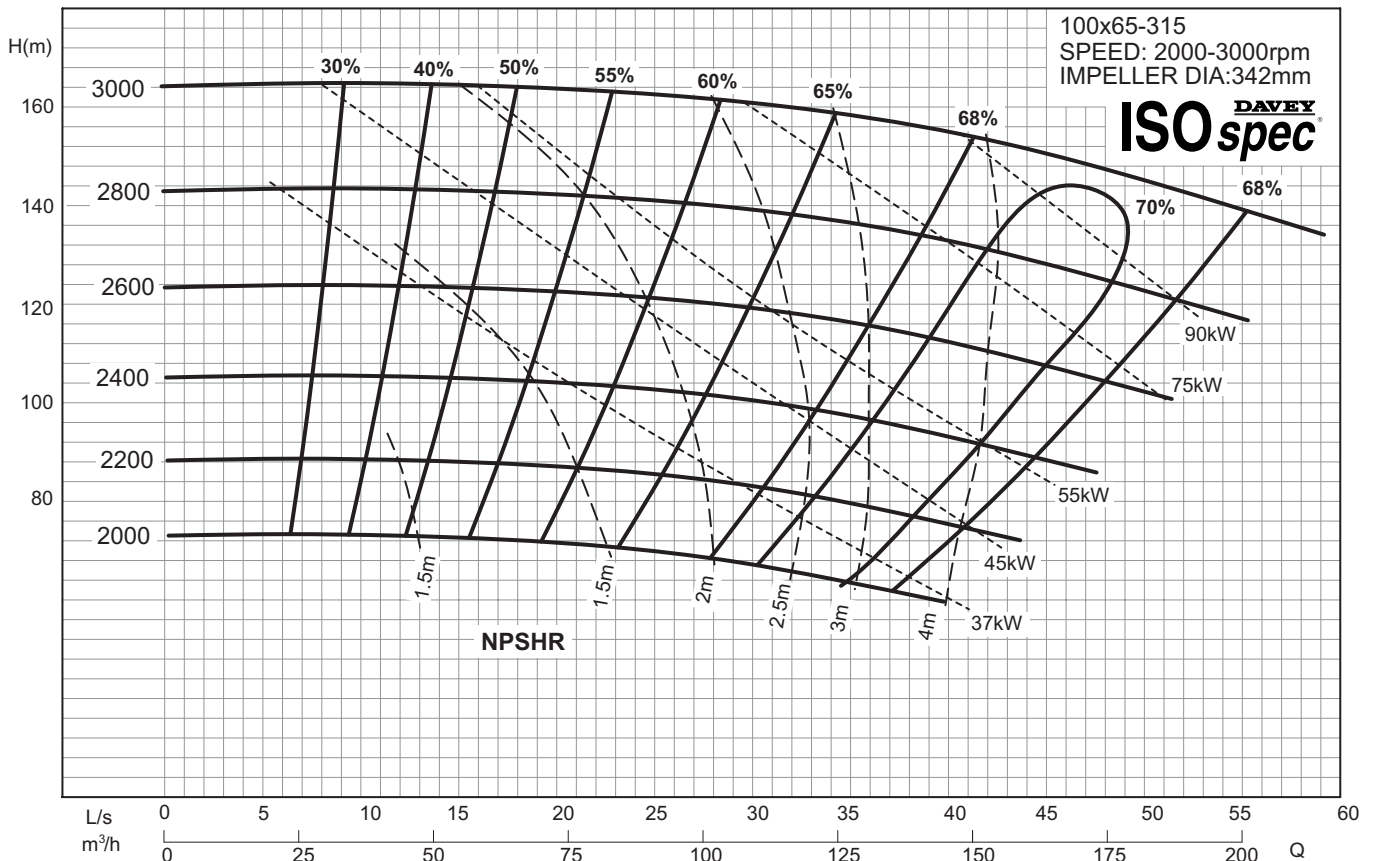
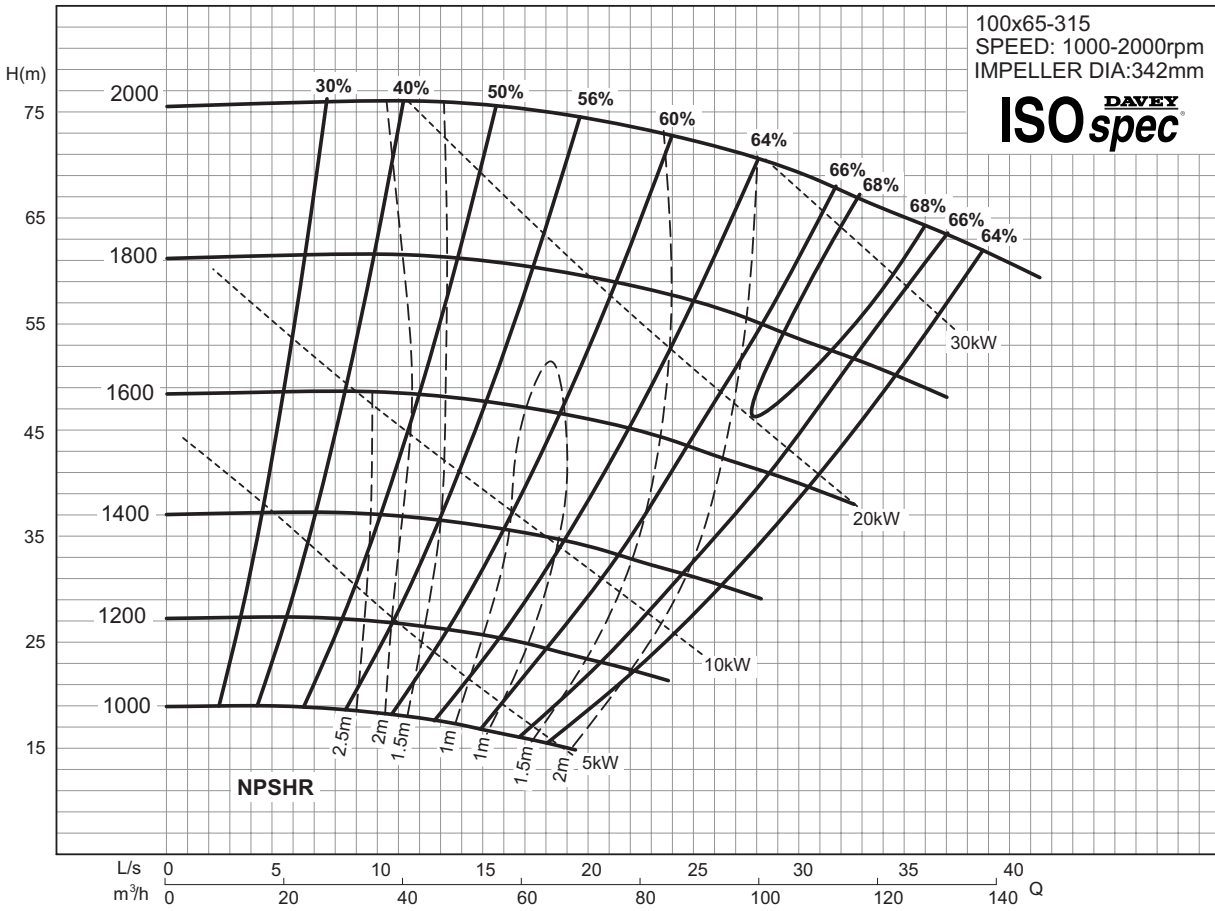

TECHNICAL SPECIFICATIONS

ISO spec DAVEY

CF Series Variable Speed Performance Curve 100x80-160

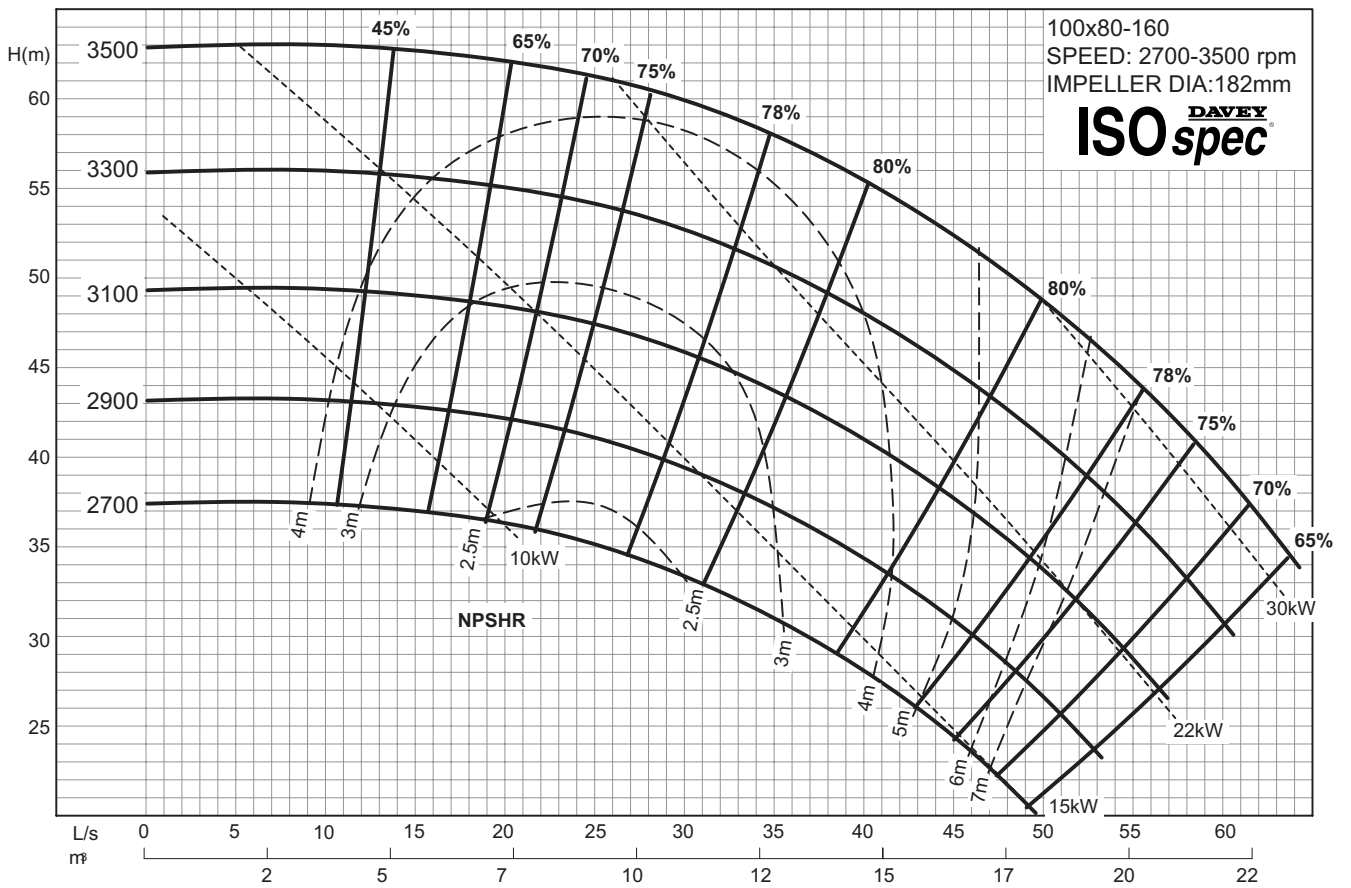
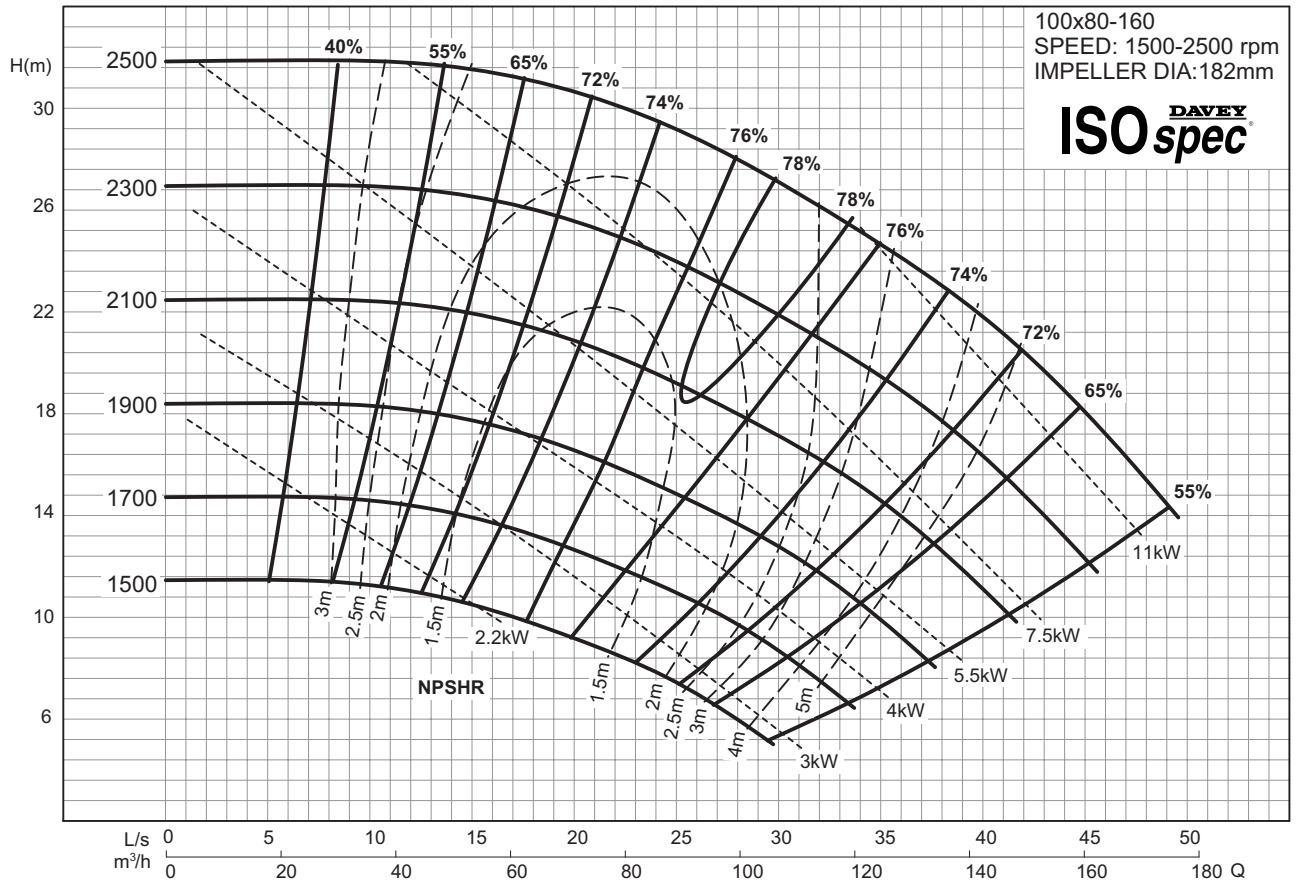

TECHNICAL SPECIFICATIONS

ISO spec ^{DAVEY}

CF Series Variable Speed Performance Curve 125x80-400

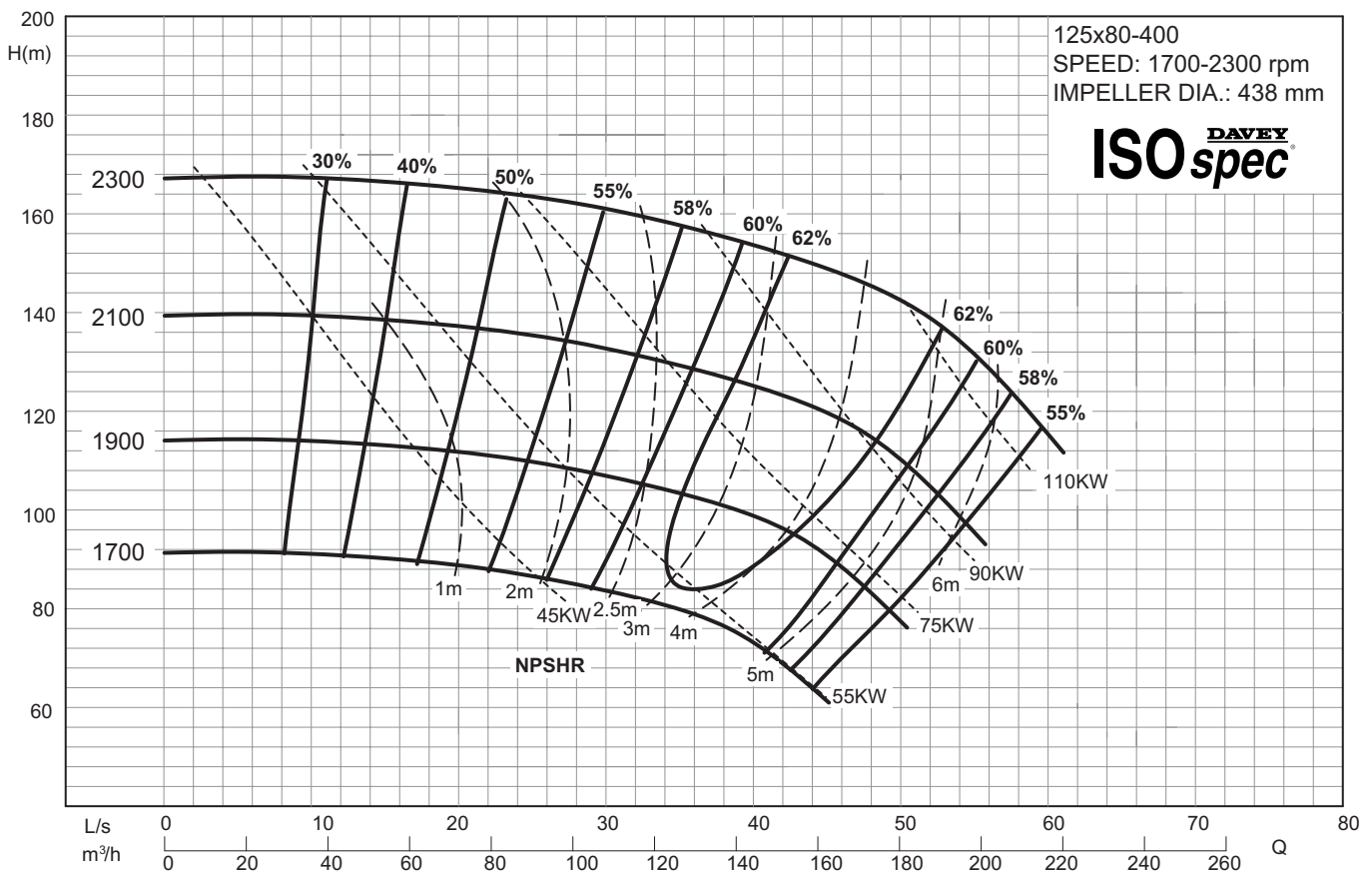
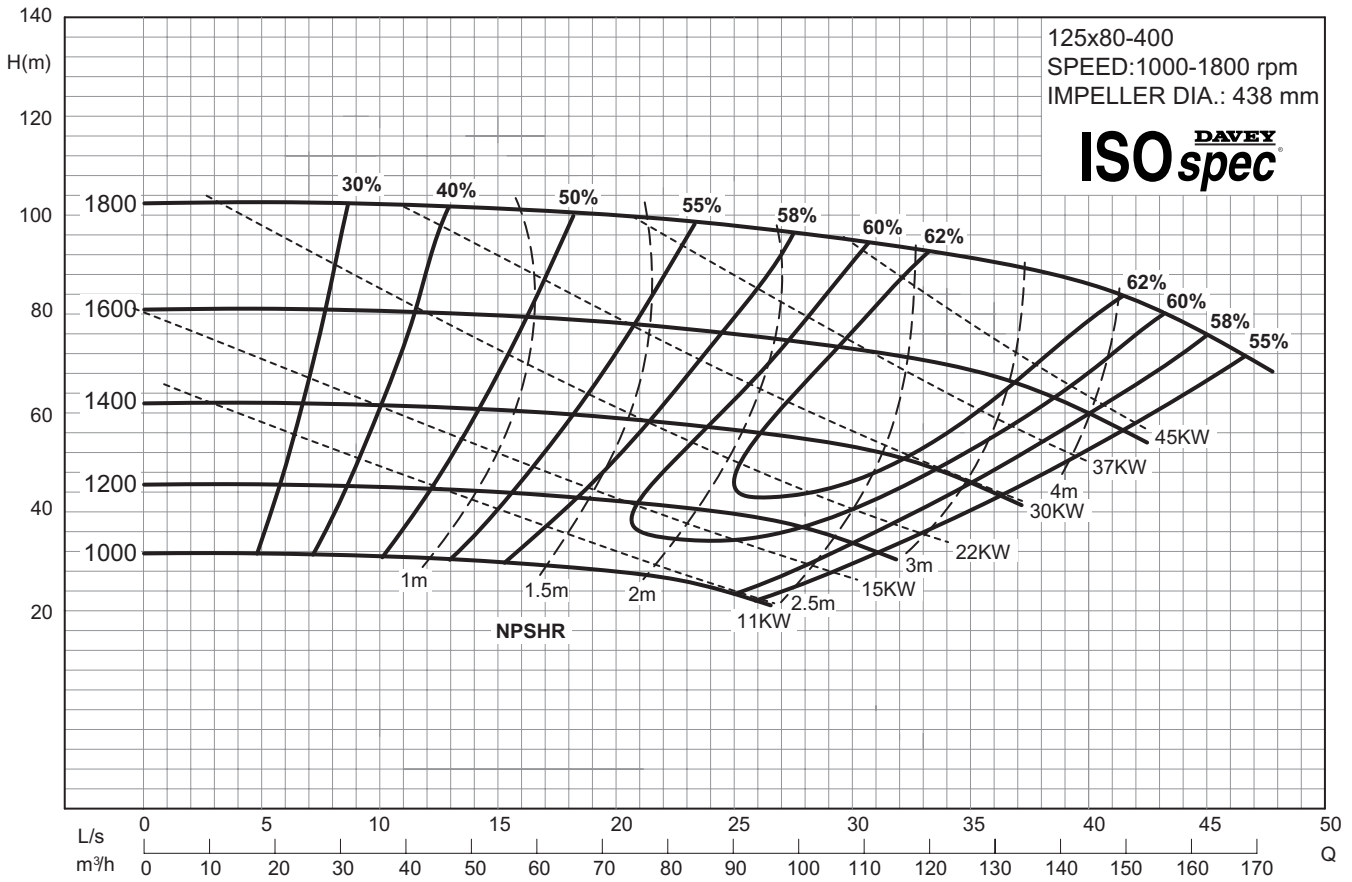

TECHNICAL SPECIFICATIONS

ISO spec ^{DAVEY} CF Series Variable Speed Performance Curve 125x100-200

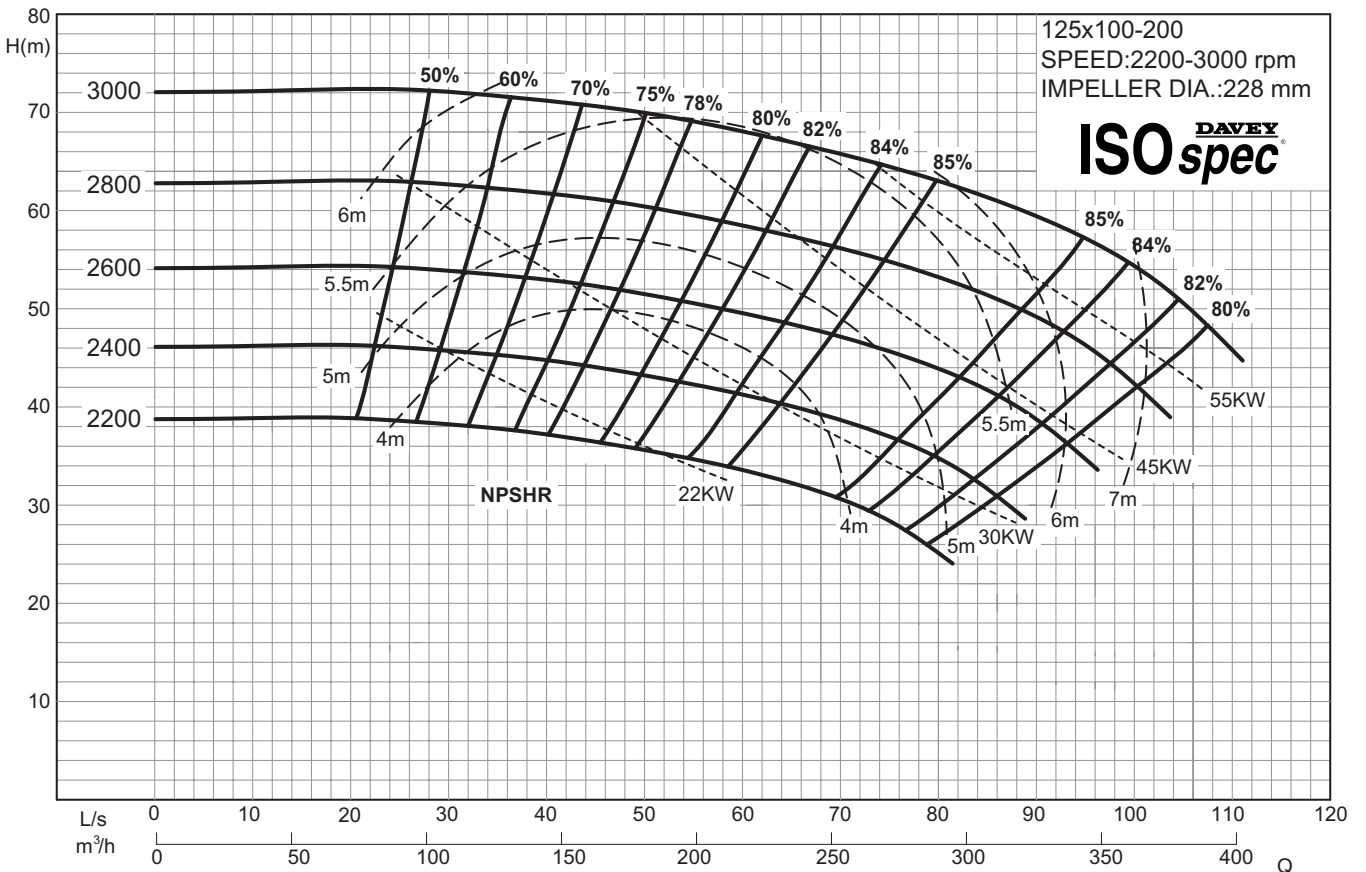
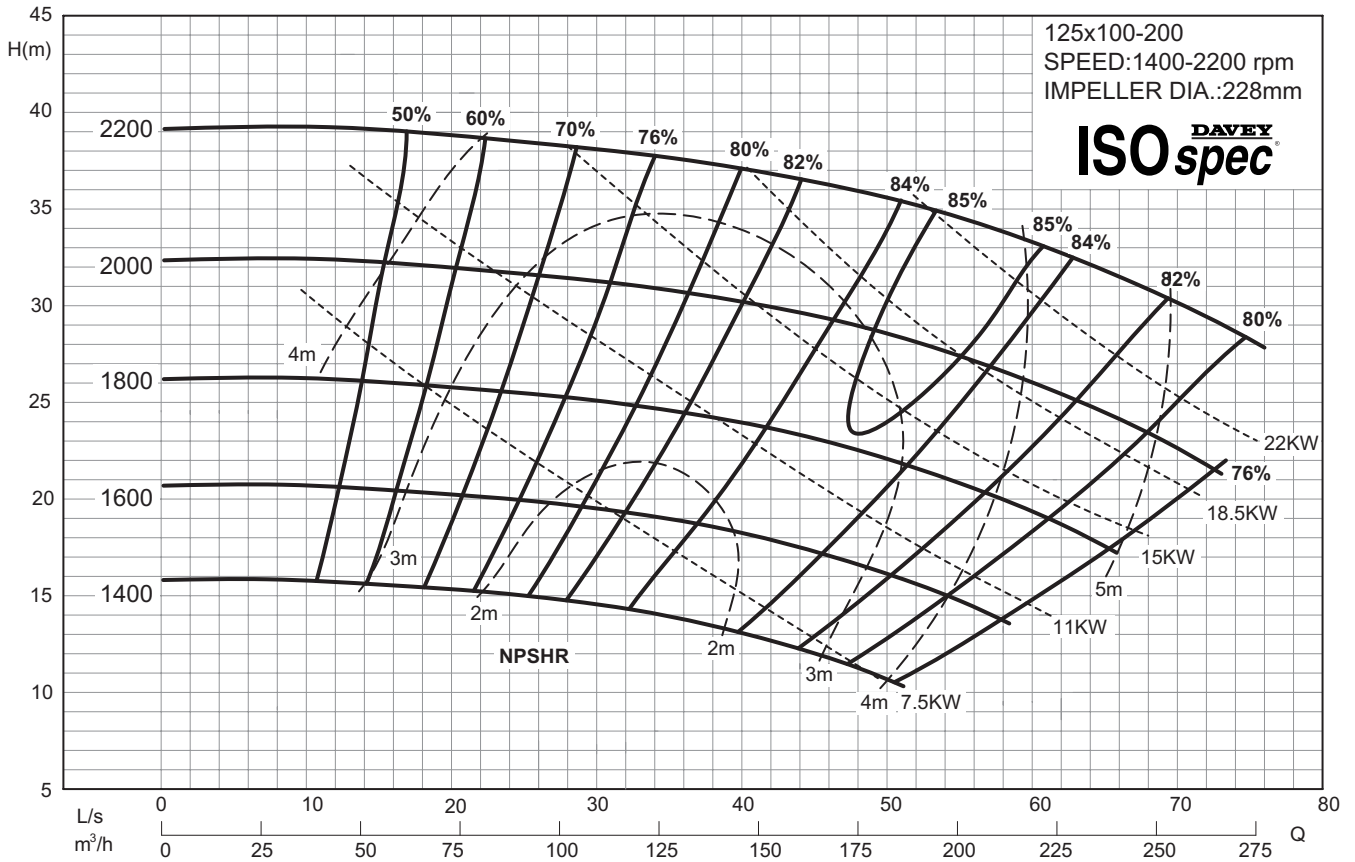

TECHNICAL SPECIFICATIONS

ISOspec[®] **DAVEY** CF Series Variable Speed Performance Curve 125x100-250

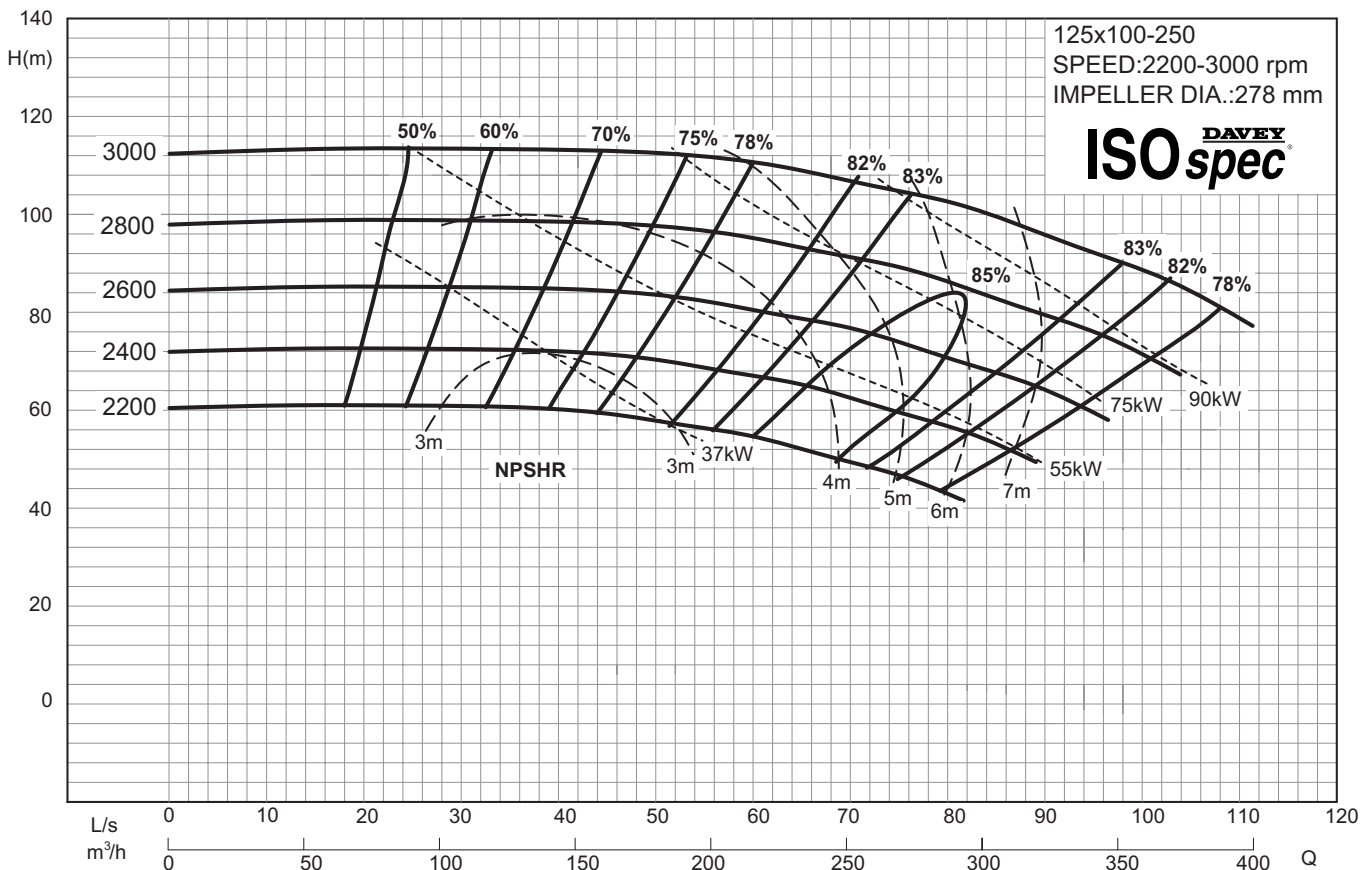
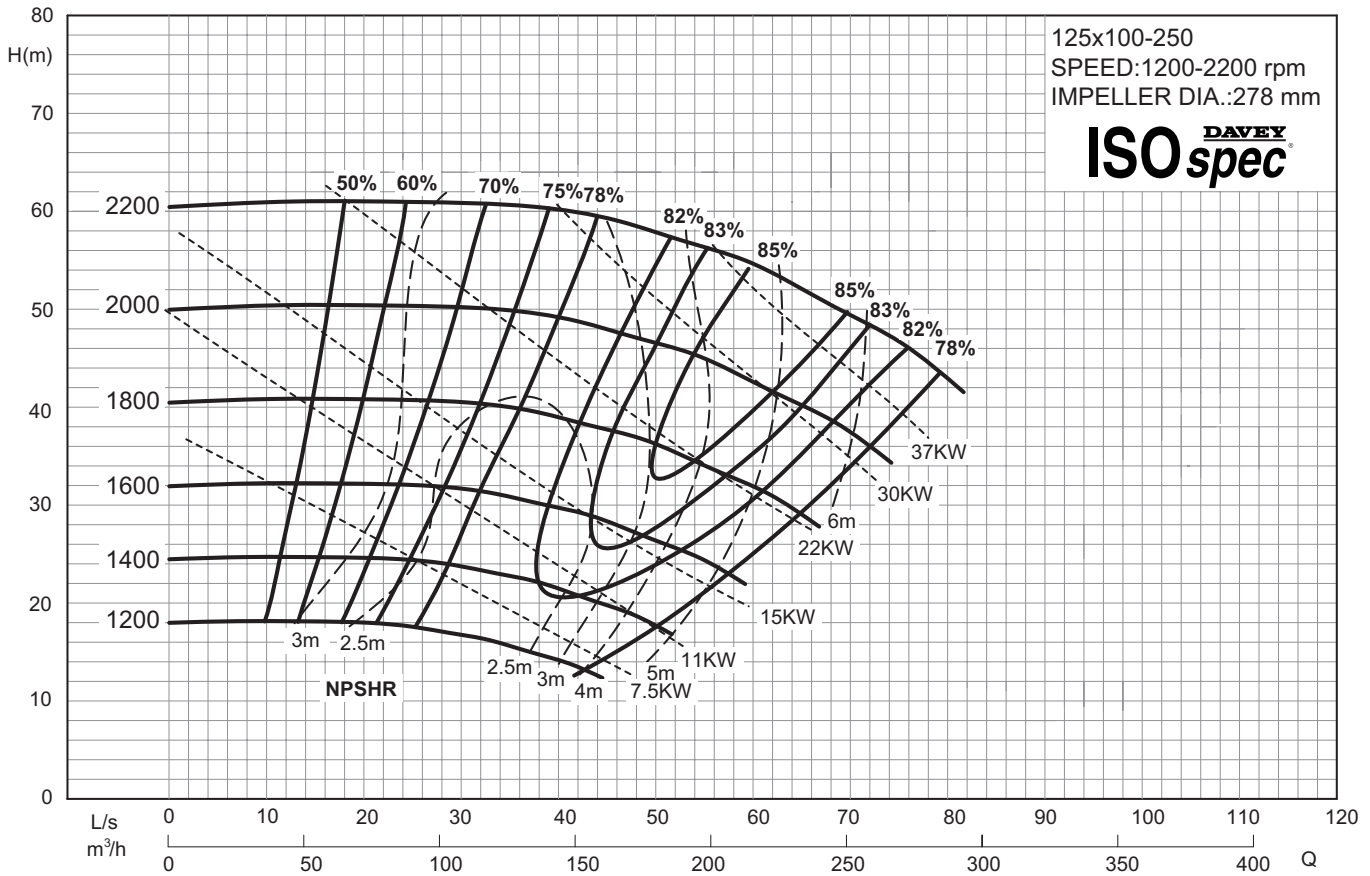

TECHNICAL SPECIFICATIONS

ISO spec ^{DAVEY} CF Series Variable Speed Performance Curve 125x100-315

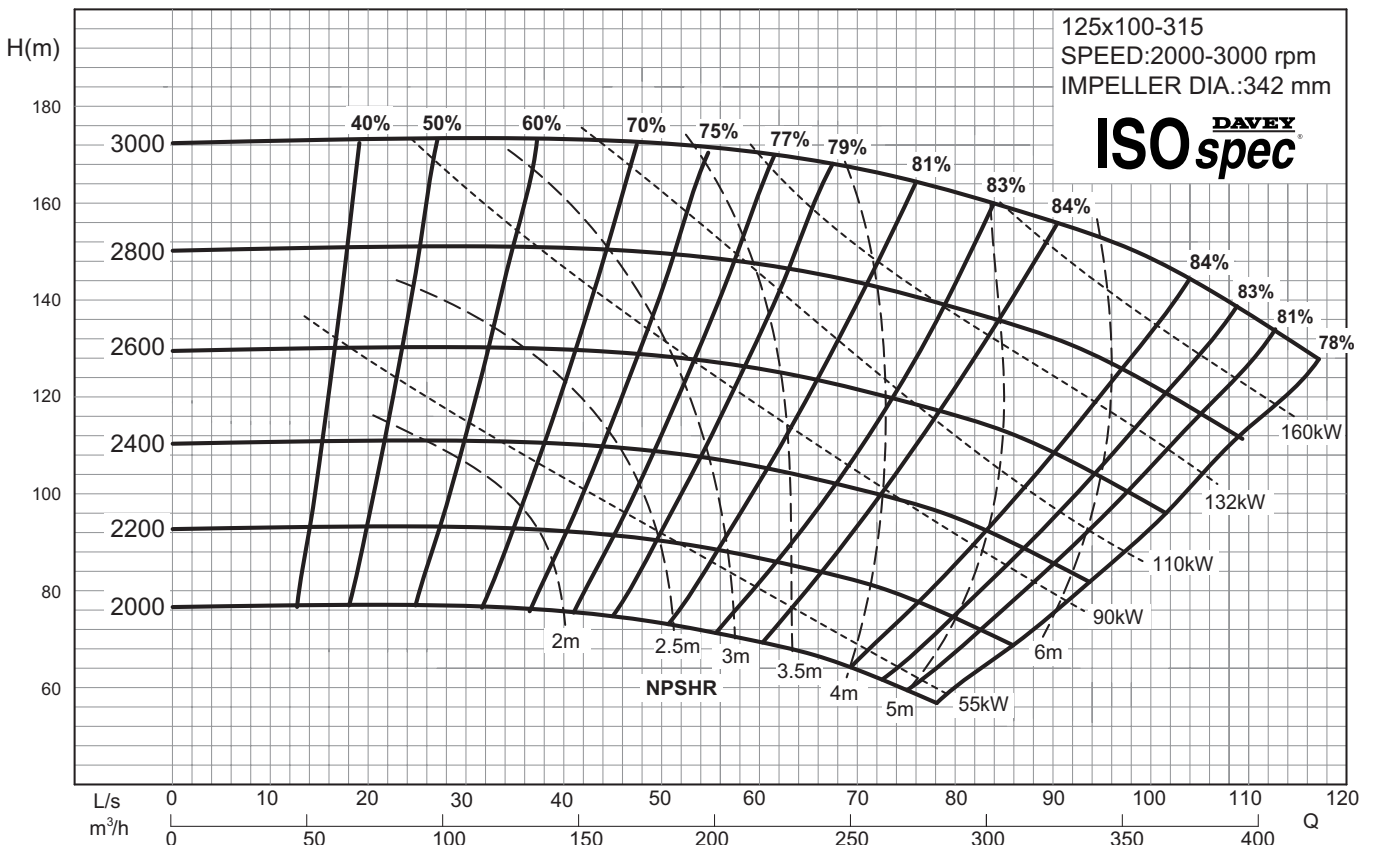
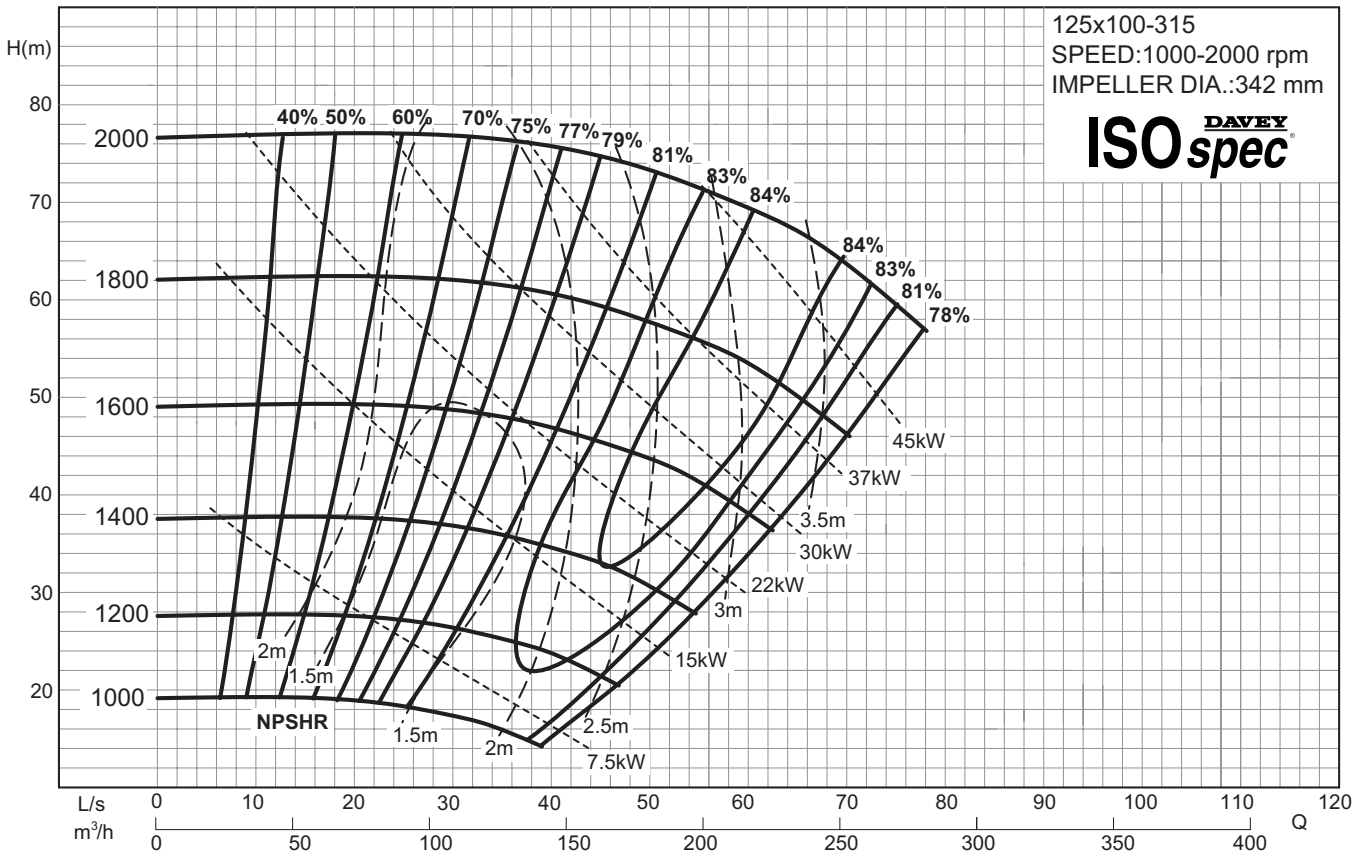

TECHNICAL SPECIFICATIONS

ISOspec[®] DAVEY CF Series Variable Speed Performance Curve 125x100-400

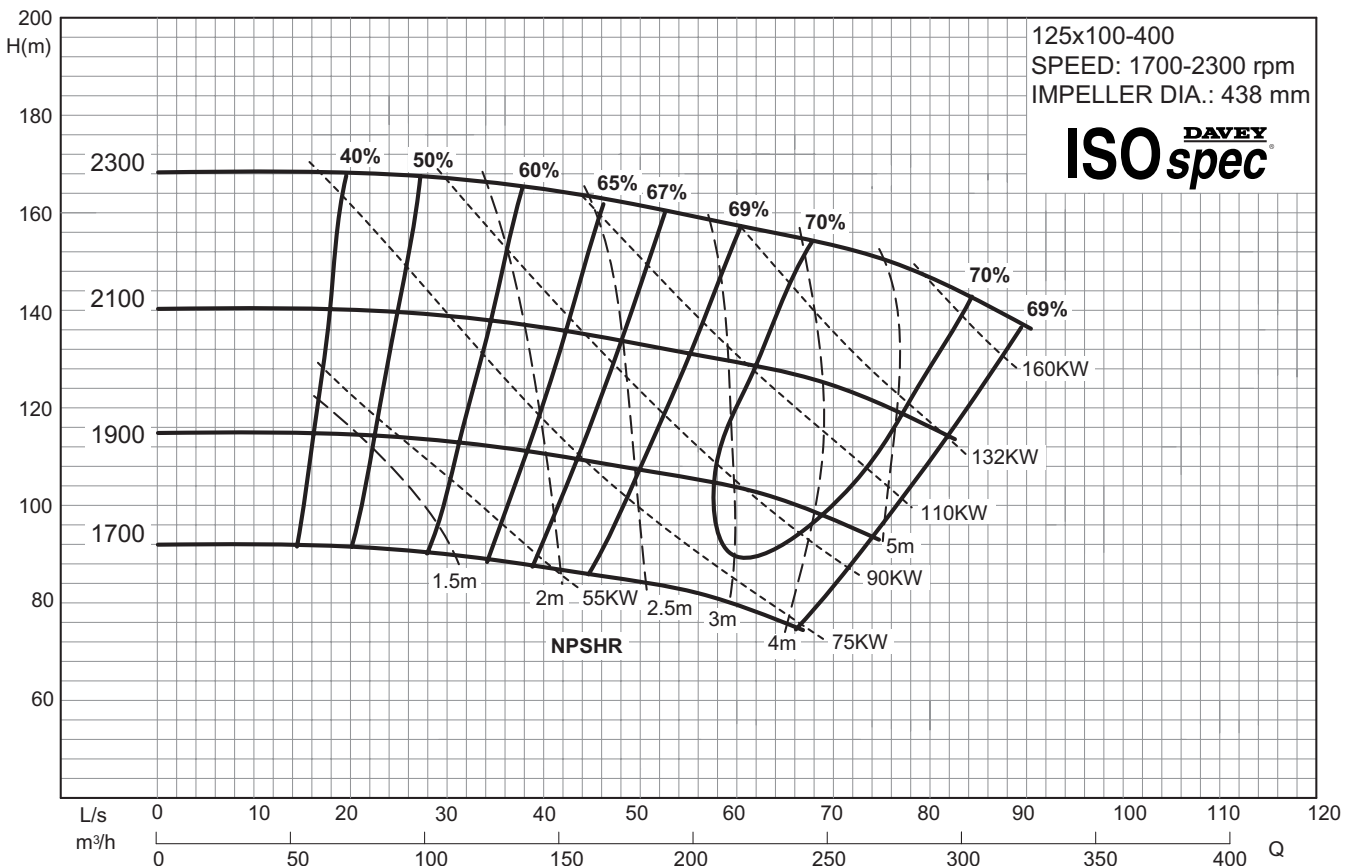
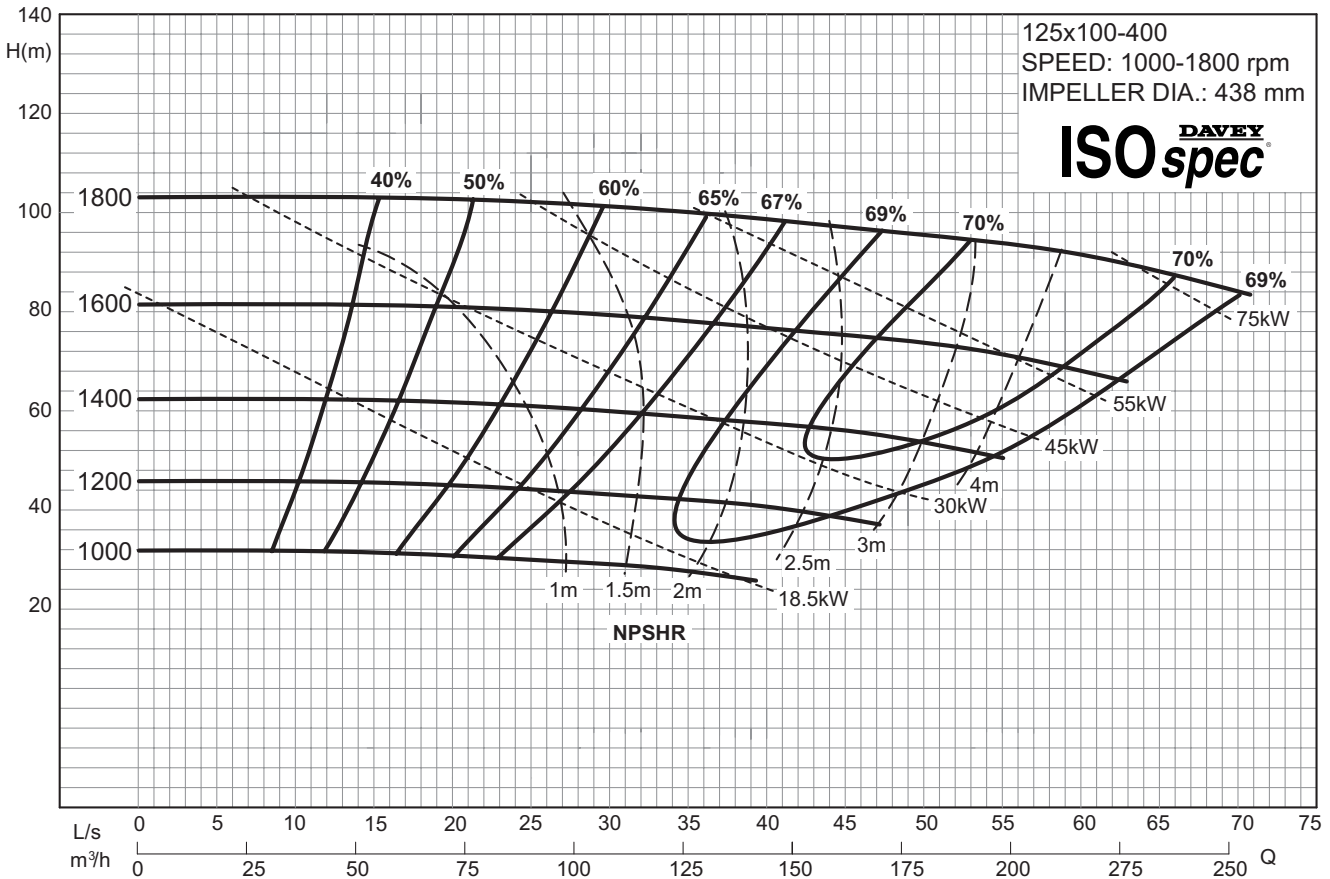

TECHNICAL SPECIFICATIONS

ISOspec[®] DAVEY CF Series Variable Speed Performance Curve 125x100-500

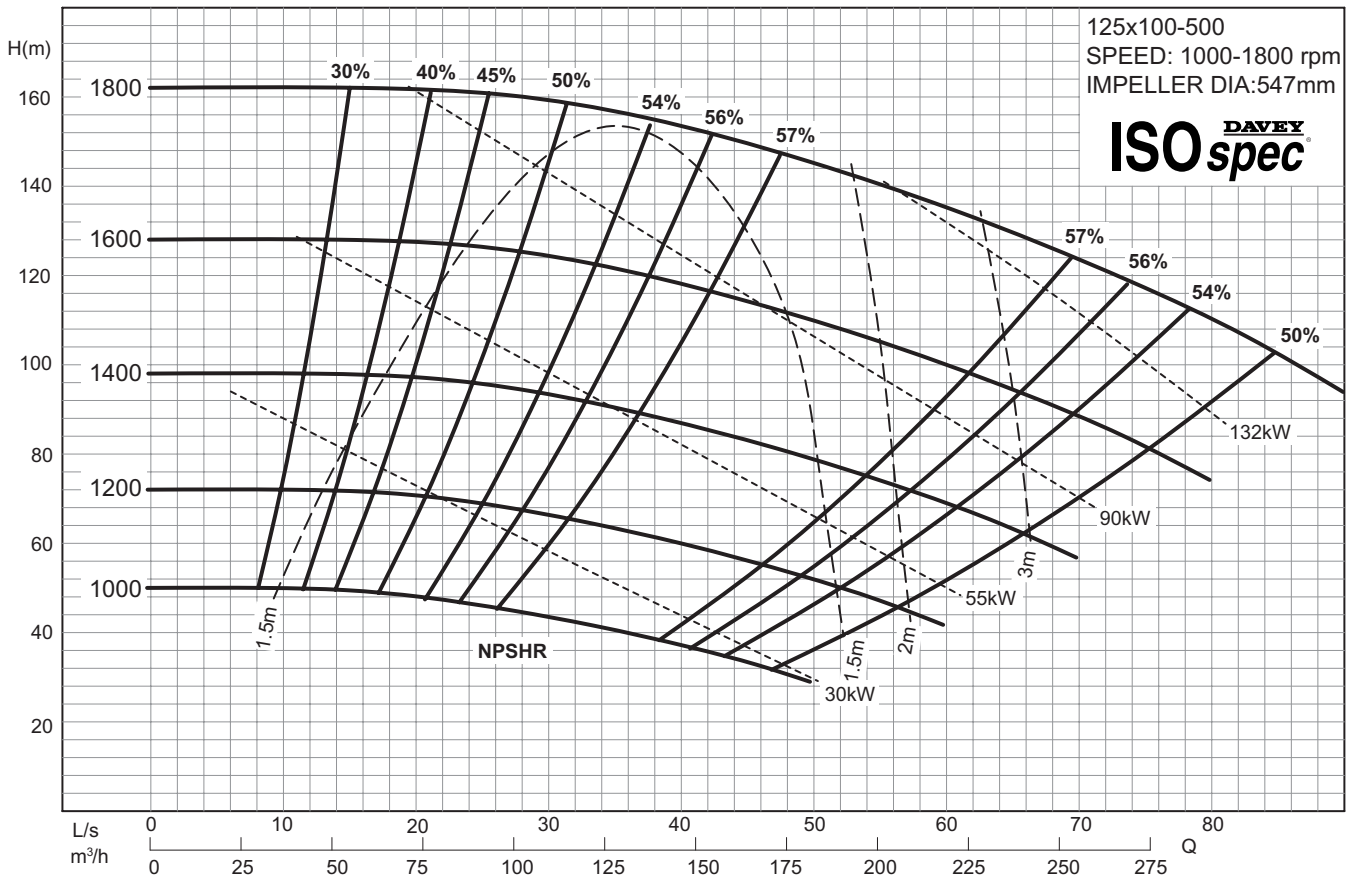

TECHNICAL SPECIFICATIONS

ISO spec ^{DAVEY} CF Series Variable Speed Performance Curve 150x125-250

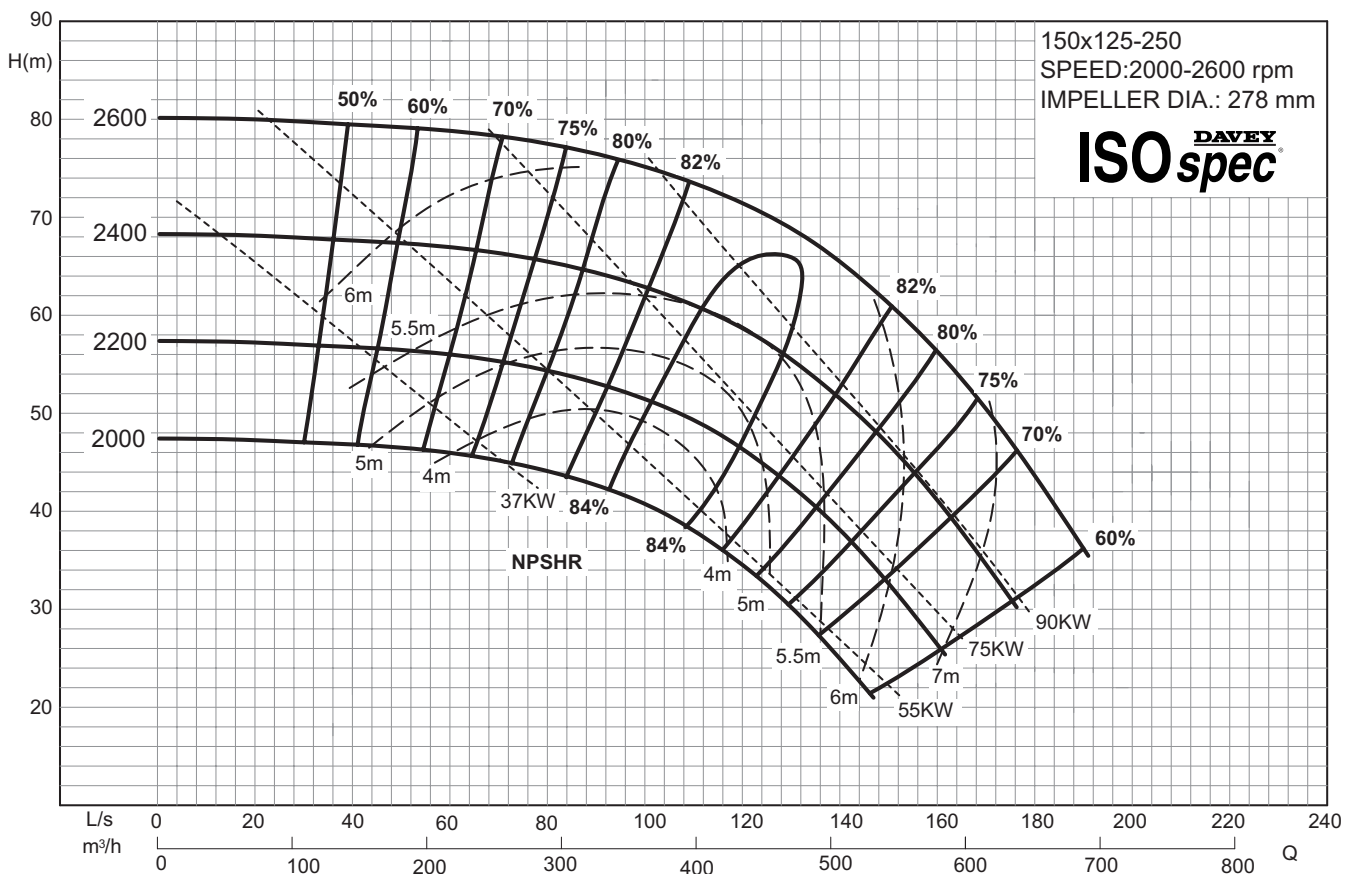
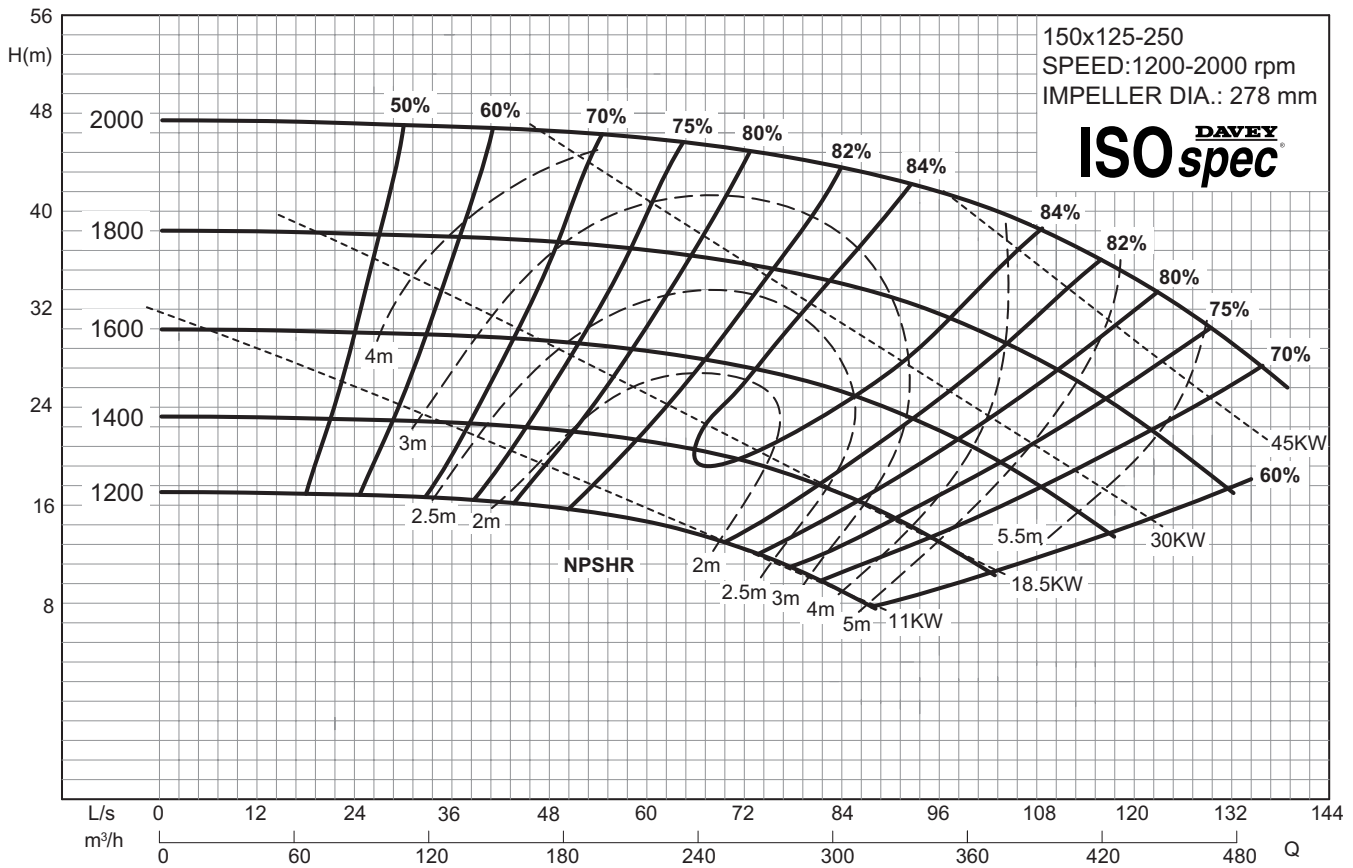

TECHNICAL SPECIFICATIONS

ISO spec ^{DAVEY} CF Series Variable Speed Performance Curve 150x125-315

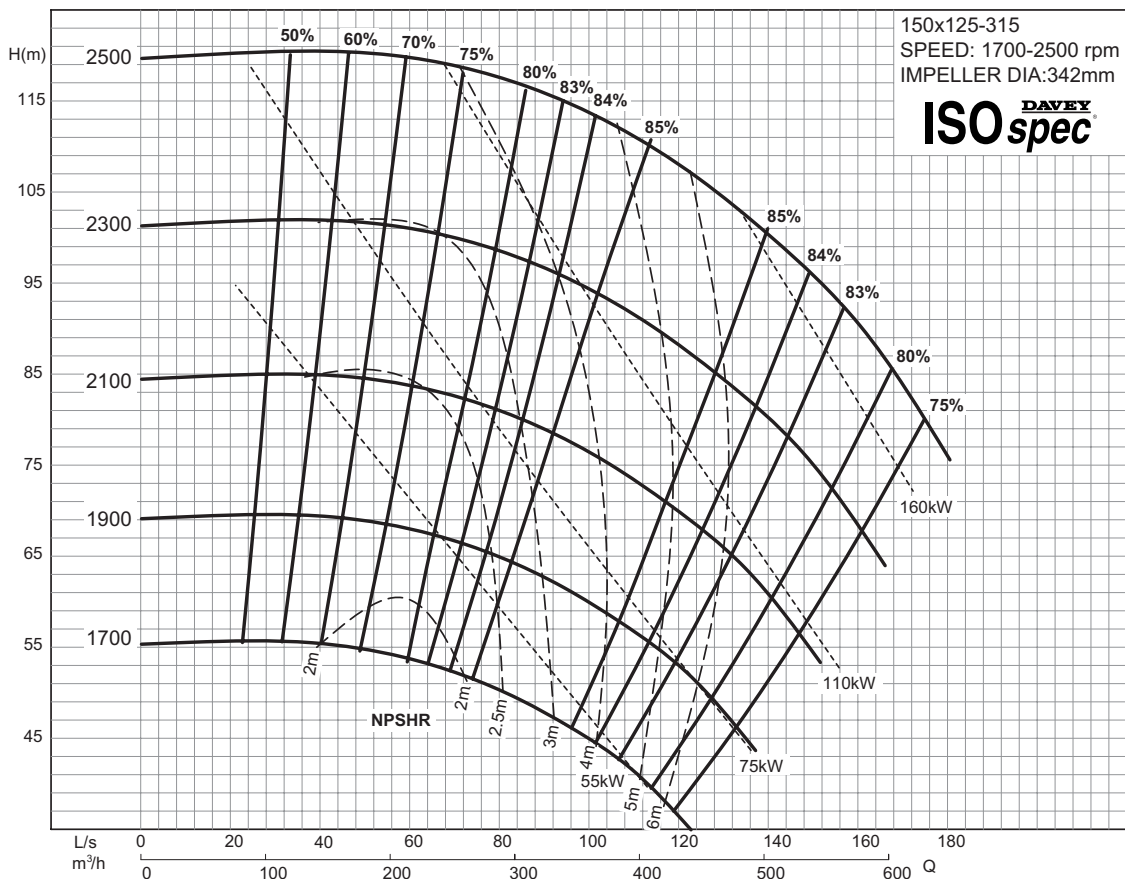
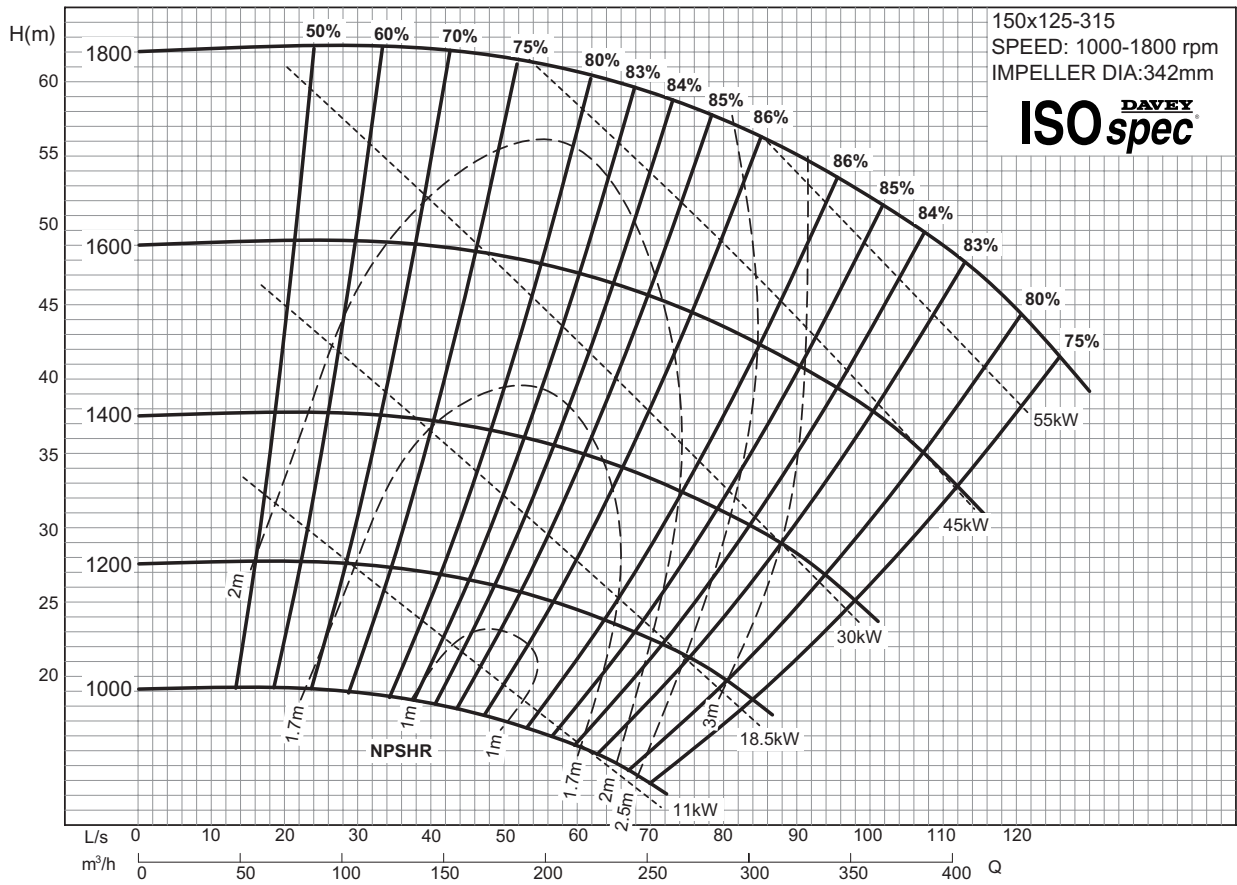

TECHNICAL SPECIFICATIONS

ISOspec[®] DAVEY CF Series Variable Speed Performance Curve 150x125-400

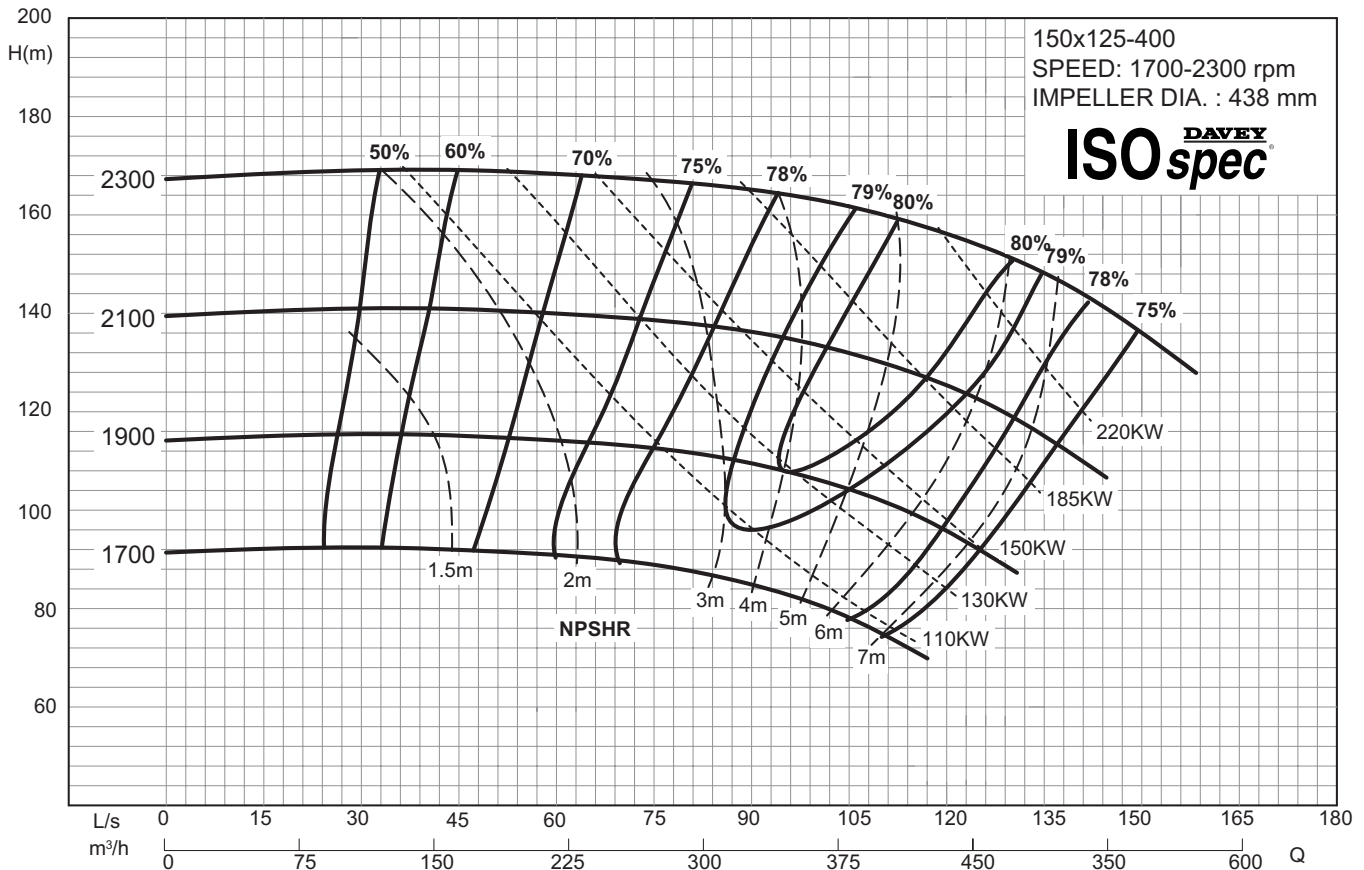
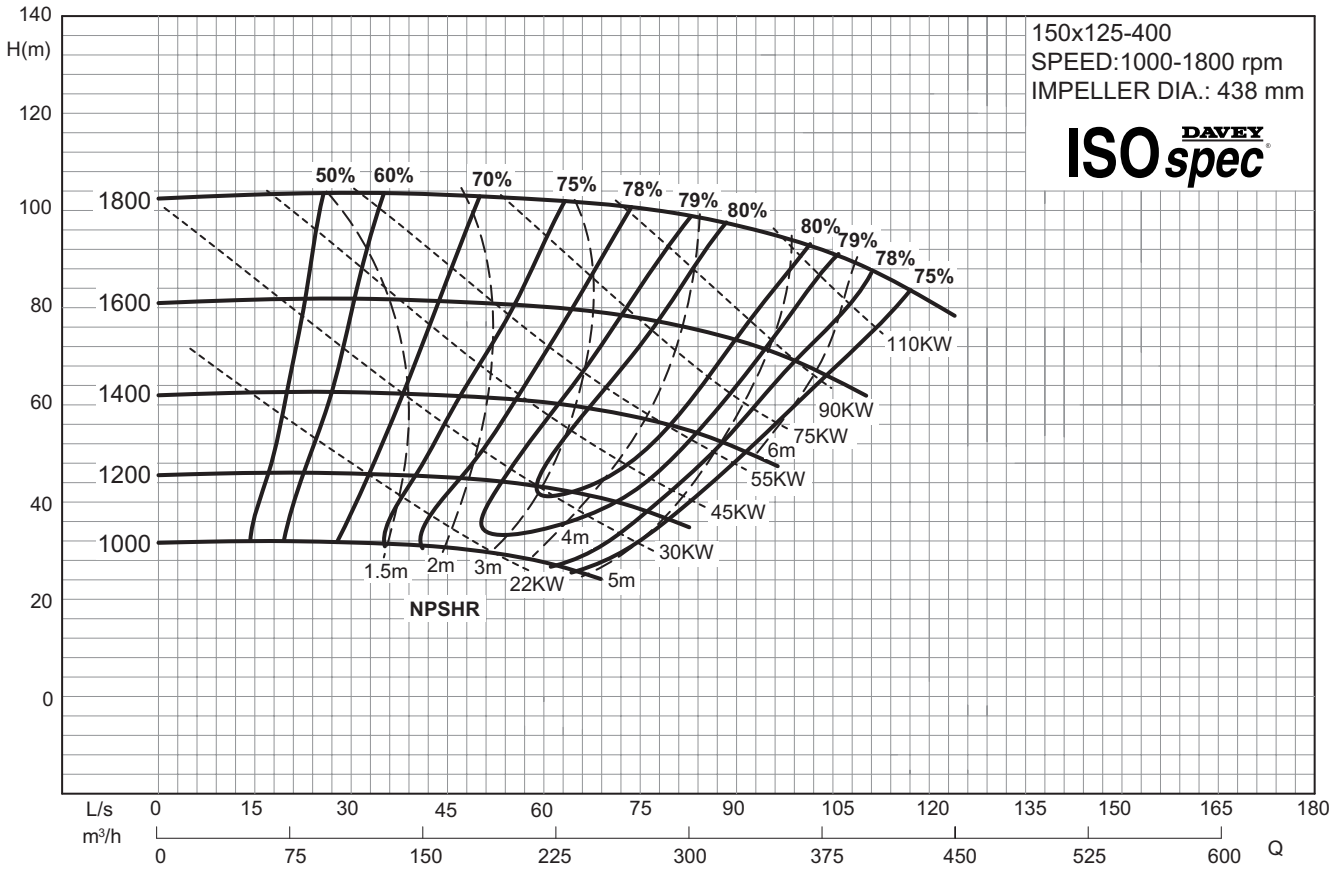

TECHNICAL SPECIFICATIONS

ISOspec[®] DAVEY CF Series Variable Speed Performance Curve 150x125-500

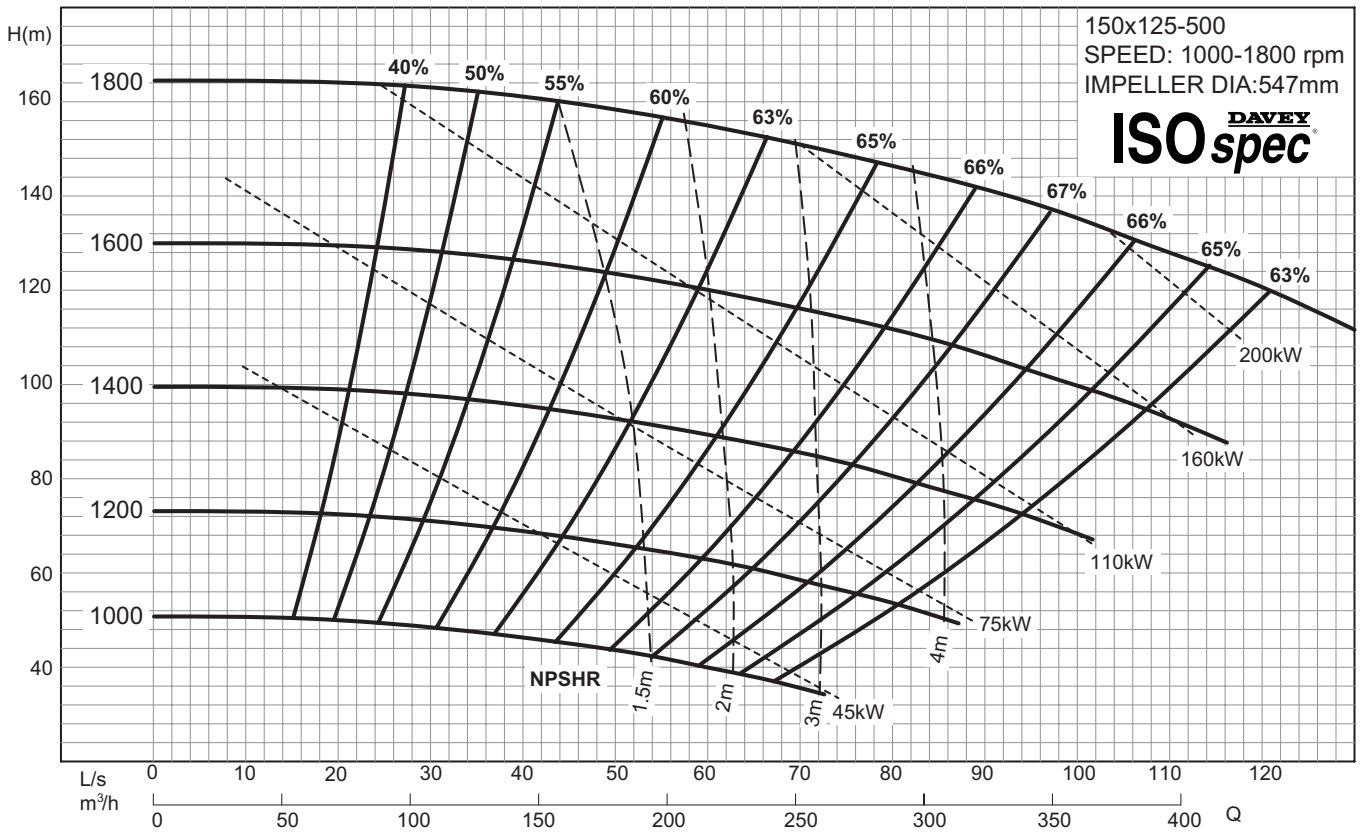

CF Series Variable Speed Performance Curve 200x150-315

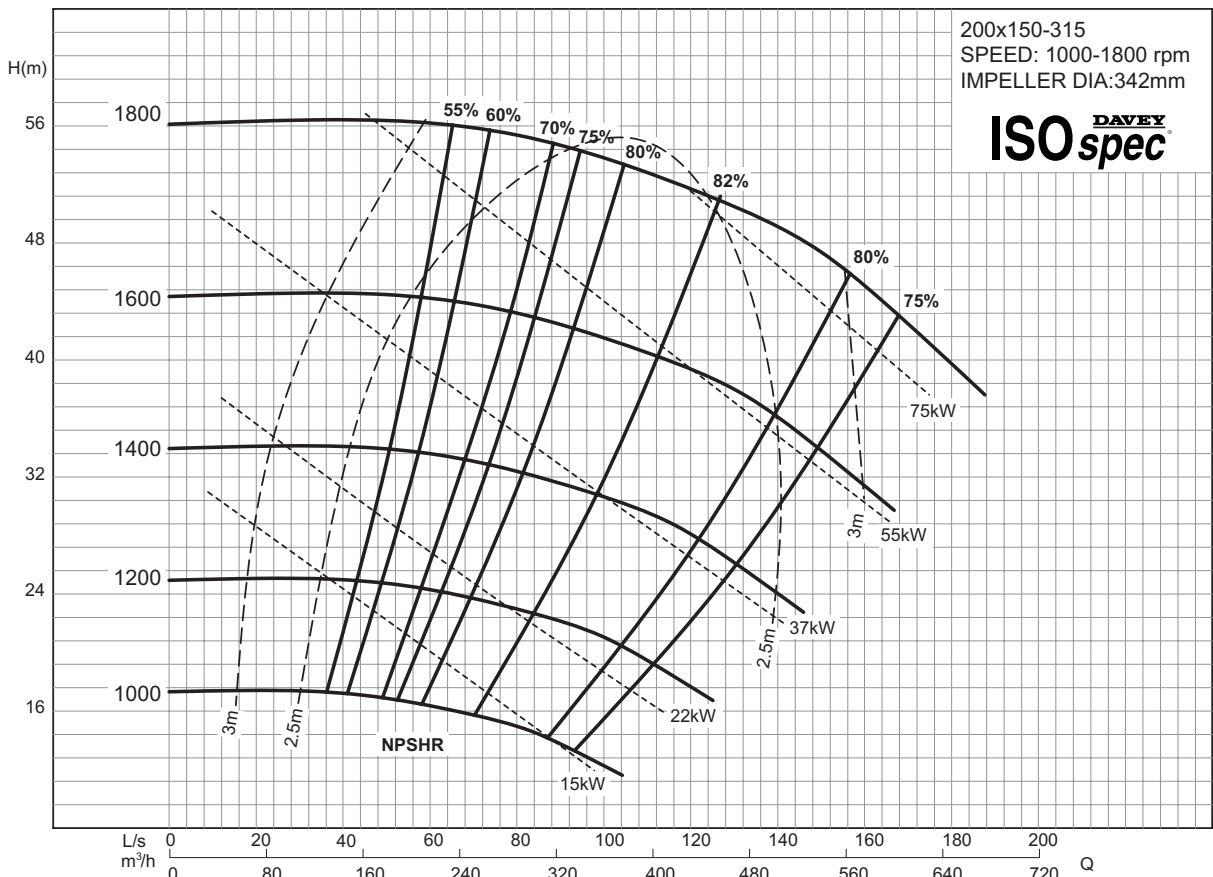

TECHNICAL SPECIFICATIONS

ISOspec[®] DAVEY CF Series Variable Speed Performance Curve 200x150-400

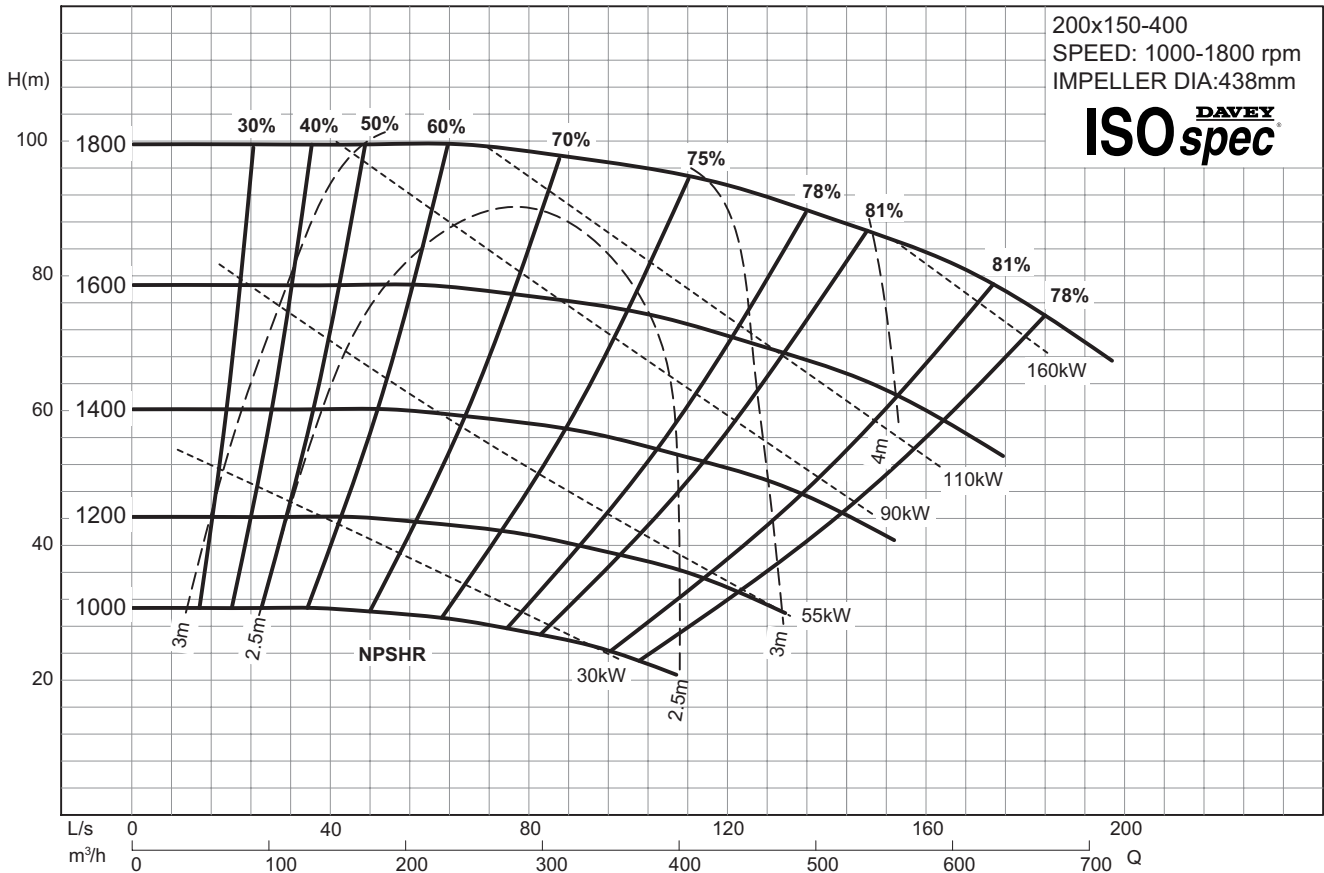

CF Series Variable Speed Performance Curve 200x150-500

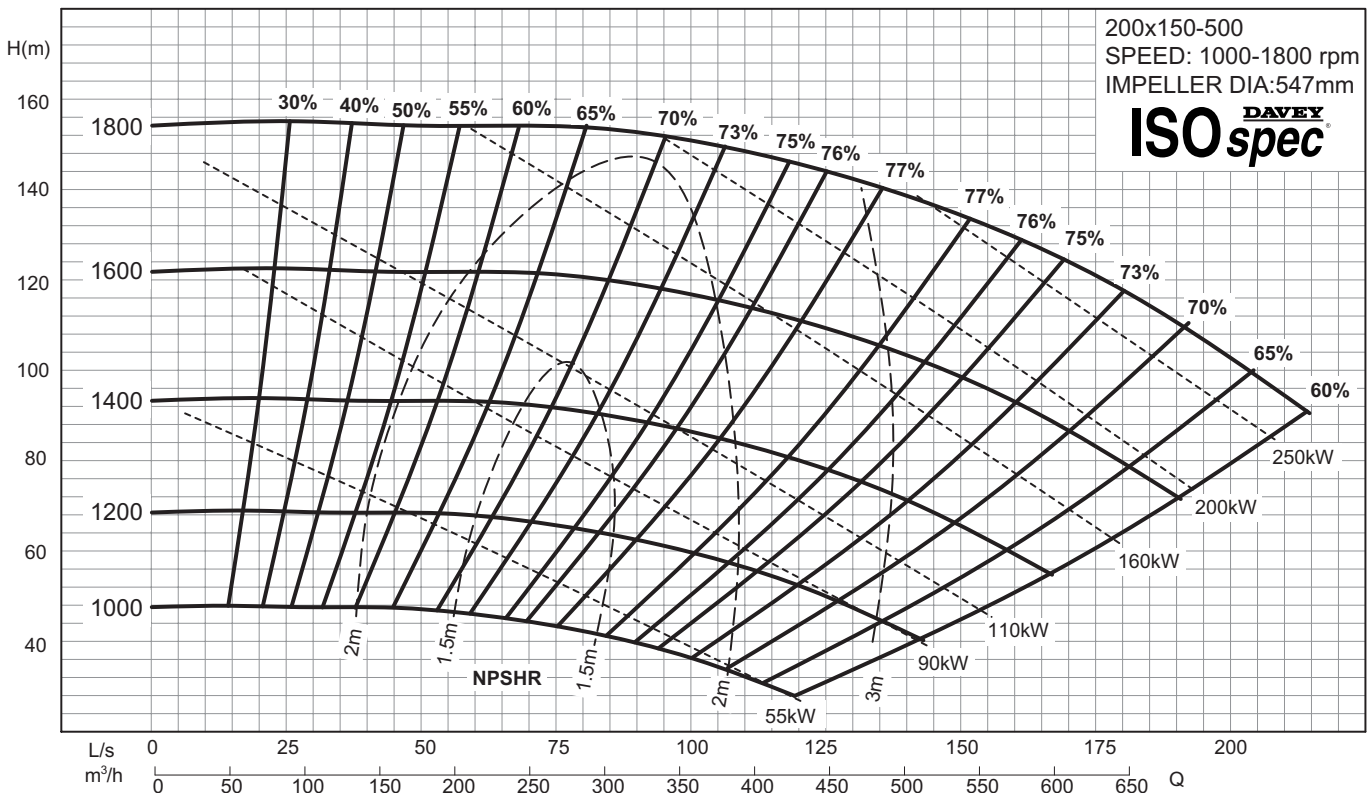

TECHNICAL SPECIFICATIONS

ISO spec ^{DAVEY} CF Series Variable Speed Performance Curve 250x200-315

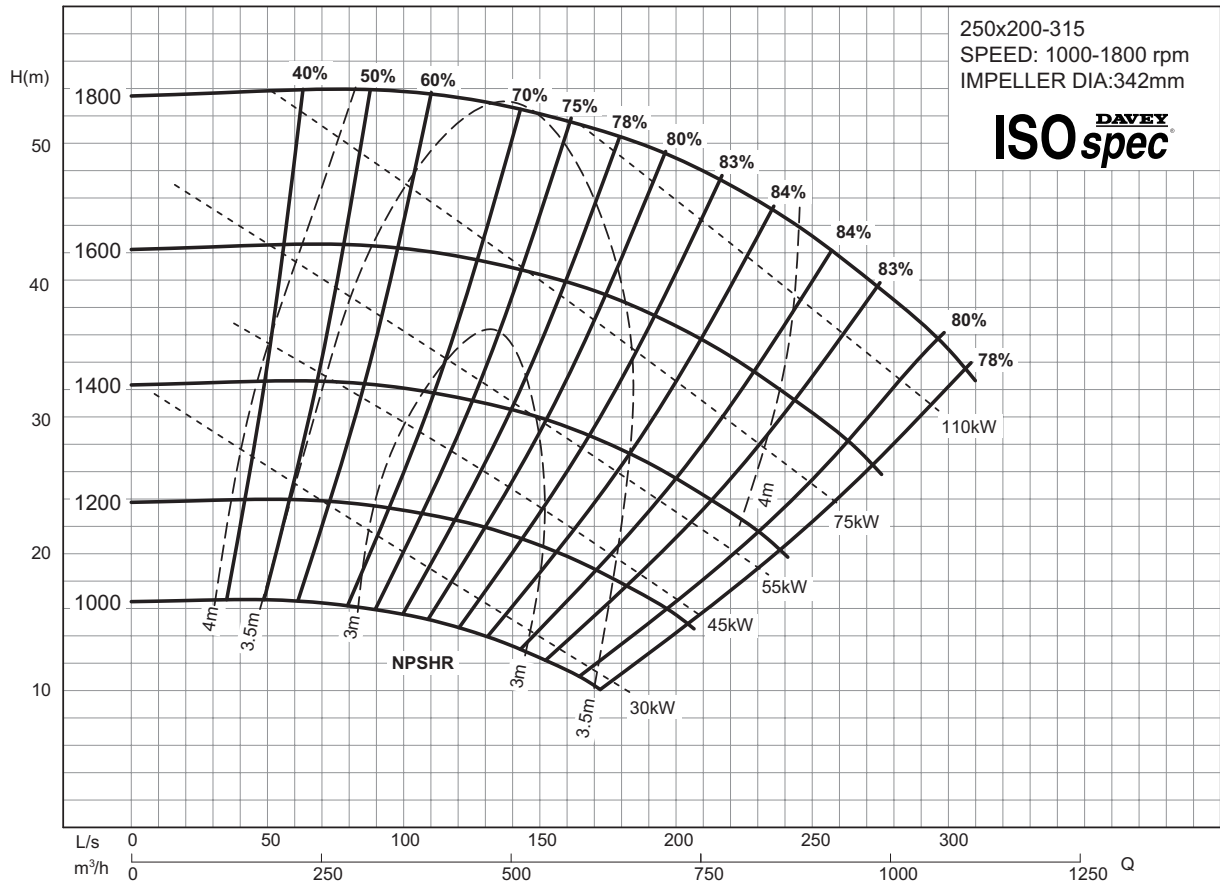

CF Series Variable Speed Performance Curve 250x200-400

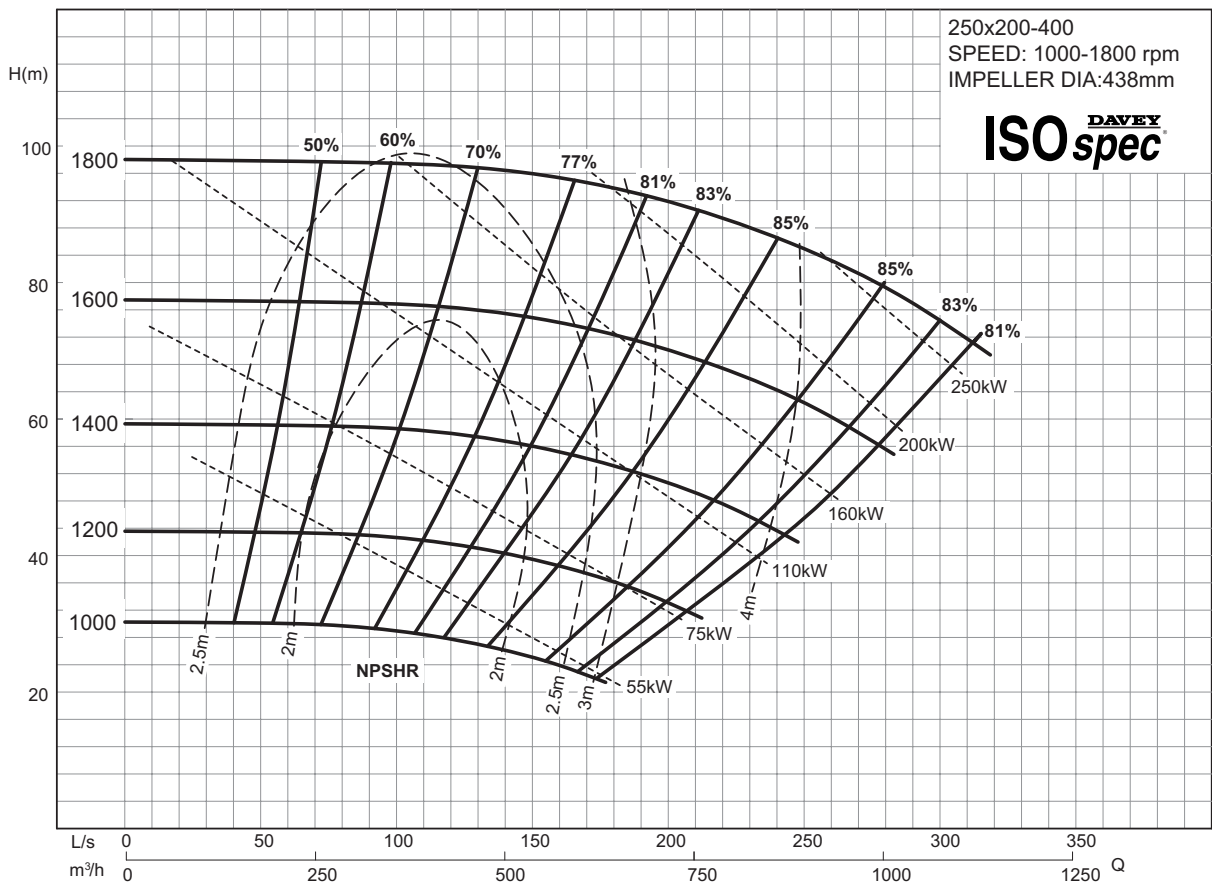

TECHNICAL SPECIFICATIONS

ISO spec ^{DAVEY}

CF Series Dimensions

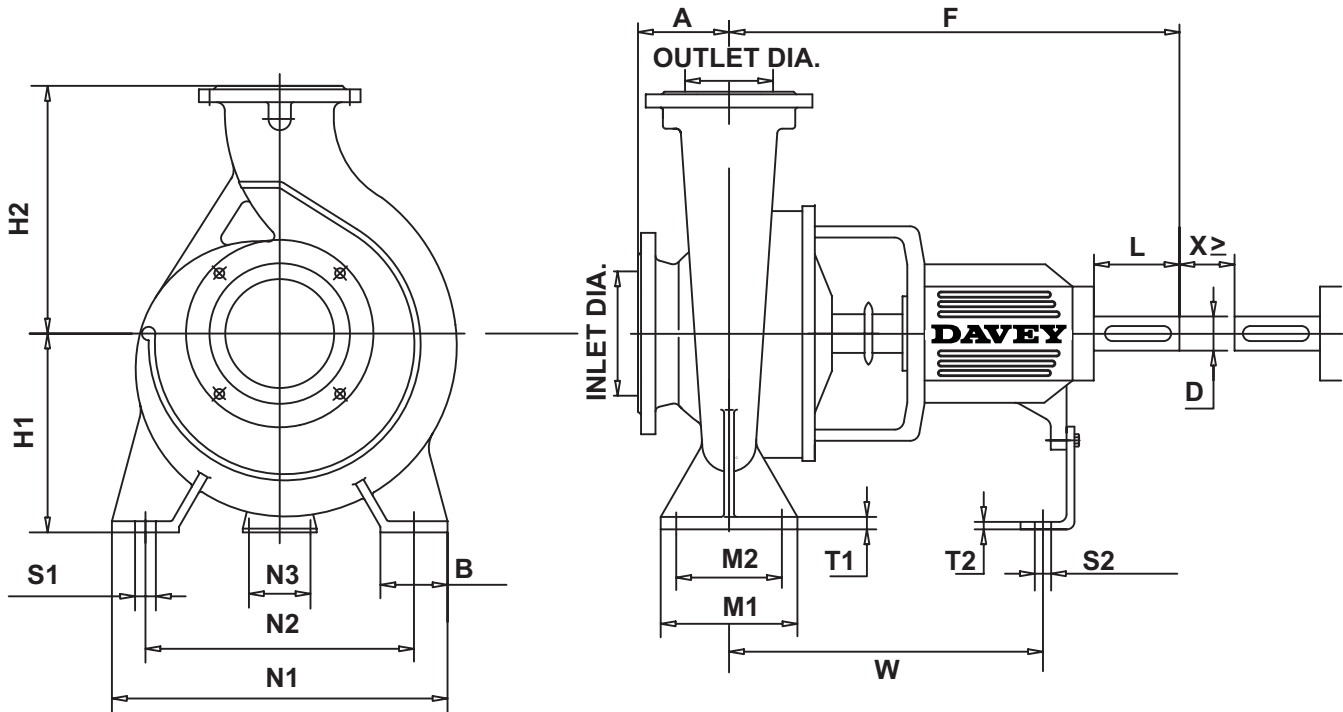

Pump End			Shaft No	Pump dimensions				Mounting Dimensions									Bolt Holes		Shaft End		Gap	Wt kg
In	Out	Imp		A	F	H1	H2	B	M1	M2	N1	N2	N3	T1	T2	W	S1	S2	D	L		
50	32	160	1	80	385	132	160	50	100	70	240	190	110	12	6	285	M12	M12	24	50	100	38
50	32	200	1	80	385	160	180	50	100	70	240	190	110	12	6	285	M12	M12	24	50	100	46
65	50	160	1	80	385	132	160	50	100	70	240	190	110	12	6	285	M12	M12	24	50	100	40
65	40	200	1	100	385	160	180	50	100	70	265	212	110	13	6	285	M12	M12	24	50	100	48
65	40	250	2	100	500	180	225	65	125	95	320	250	110	14	6	370	M12	M12	32	80	100	70
65	40	315	2	125	500	200	250	65	125	95	345	280	110	16	6	370	M12	M12	32	80	100	80
80	65	160	1	100	385	160	180	50	100	70	265	212	110	13	6	285	M12	M12	24	50	100	46
80	50	200	1	100	385	160	200	50	100	70	265	212	110	13	6	285	M12	M12	24	50	100	52
80	50	250	2	125	500	180	225	65	125	95	320	250	110	15	6	370	M12	M12	32	80	100	72
80	50	315	2	125	500	225	280	65	125	95	345	280	110	18	6	370	M12	M12	32	80	100	87
100	80	160	2	100	500	160	200	65	125	95	280	212	110	14	6	370	M12	M12	32	80	100	68
100	65	200	2	100	500	180	225	65	125	95	320	250	110	14	6	370	M12	M12	32	80	140	70
100	65	250	2	125	500	200	250	80	160	120	360	280	110	16	6	370	M16	M12	32	80	140	80
100	65	315	3	125	530	225	280	80	160	120	400	315	110	18	6	370	M16	M12	42	110	140	118
125	80	400	3	125	530	280	355	80	160	120	435	355	110	20	6	370	M16	M12	42	110	140	165
125	100	200	2	125	500	200	280	80	160	120	360	280	110	17	6	370	M16	M12	32	80	140	85
125	100	250	3	140	530	225	280	80	160	120	400	315	110	18	6	370	M16	M12	42	110	140	126
125	100	315	3	140	530	250	315	80	160	120	400	315	110	19	6	370	M16	M12	42	110	140	135
125	100	400	3	140	530	280	355	100	200	150	500	400	110	20	6	370	M20	M12	42	110	140	175
125	100	500	4	160	670	355	450	100	200	150	550	450	110	25	10	500	M20	M16	48	110	180	313
150	125	250	3	140	530	250	355	80	160	120	400	315	110	19	6	370	M16	M12	42	110	140	140
150	125	315	3	140	530	280	355	100	200	150	500	400	110	20	6	370	M20	M12	42	110	140	150
150	125	400	3	140	530	315	400	100	200	150	500	400	110	21	6	370	M20	M12	42	110	140	186
150	125	500	4	160	670	355	450	100	200	150	550	450	110	25	10	500	M20	M16	48	110	180	336
200	150	315	4	160	670	315	400	100	200	150	550	450	140	25	10	500	M20	M16	48	110	180	222
200	150	400	4	160	670	315	450	100	200	150	550	450	140	25	10	500	M20	M16	48	110	180	300
200	150	500	4	160	670	400	500	100	200	150	550	450	140	25	10	500	M20	M16	48	110	180	382
250	200	315	4	180	670	315	450	100	200	150	550	450	140	25	10	500	M20	M16	48	110	180	277
250	200	400	4	180	670	355	500	100	200	150	550	450	140	25	10	500	M20	M16	48	110	180	340

- Notes:
1. Standard flange drilling to AS2129 Table E: 16 bar rating.
 2. Dimensions in mm.
 3. Gap necessary for the withdrawal of bearing housing, back cover and impeller assembly towards the drive end.

TECHNICAL SPECIFICATIONS



CF Series Shaft Dimensions

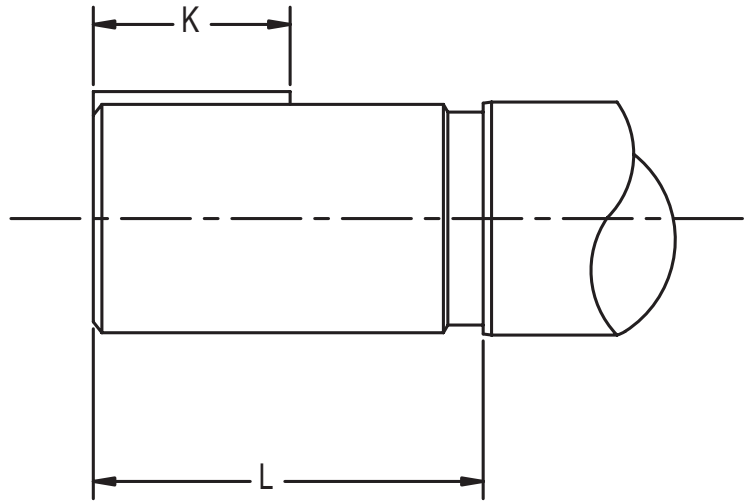
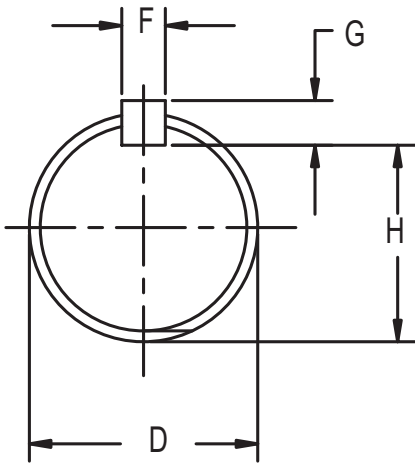

Module	Diameter Tolerance D	Key Width F	Key Height G	Keyway Depth Tolerance H	Key Length K	Working Length L
No. 1	24mm +0.015/-0.002	8	7	20mm +0/-0.2	32	50
No. 2	32mm +0.018/-0.002	10	8	27mm +0/-0.2	50	80
No. 3	42mm +0.018/-0.002	12	8	37mm +0/-0.2	60	110
No. 4	48mm +0.018/-0.002	14	9	42.5mm +0/-0.2	80	110

All dimensions in mm, unless otherwise stated.

TECHNICAL SPECIFICATIONS



CF Series Shaft Module No. 1

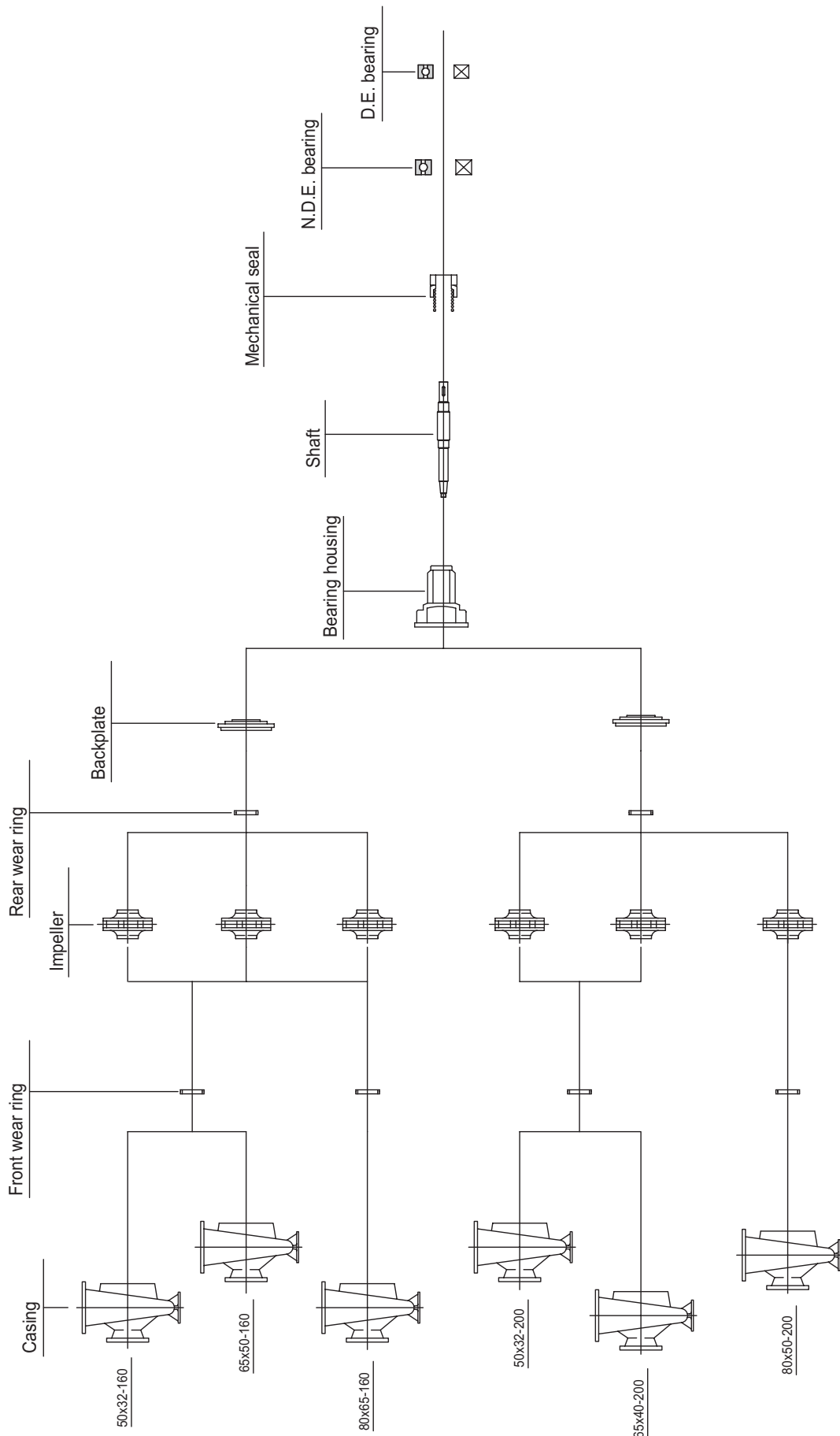

All pump sizes listed above use Bearing Frame and Shaft Module No. 1.

TECHNICAL SPECIFICATIONS



CF Series Shaft Module No. 2

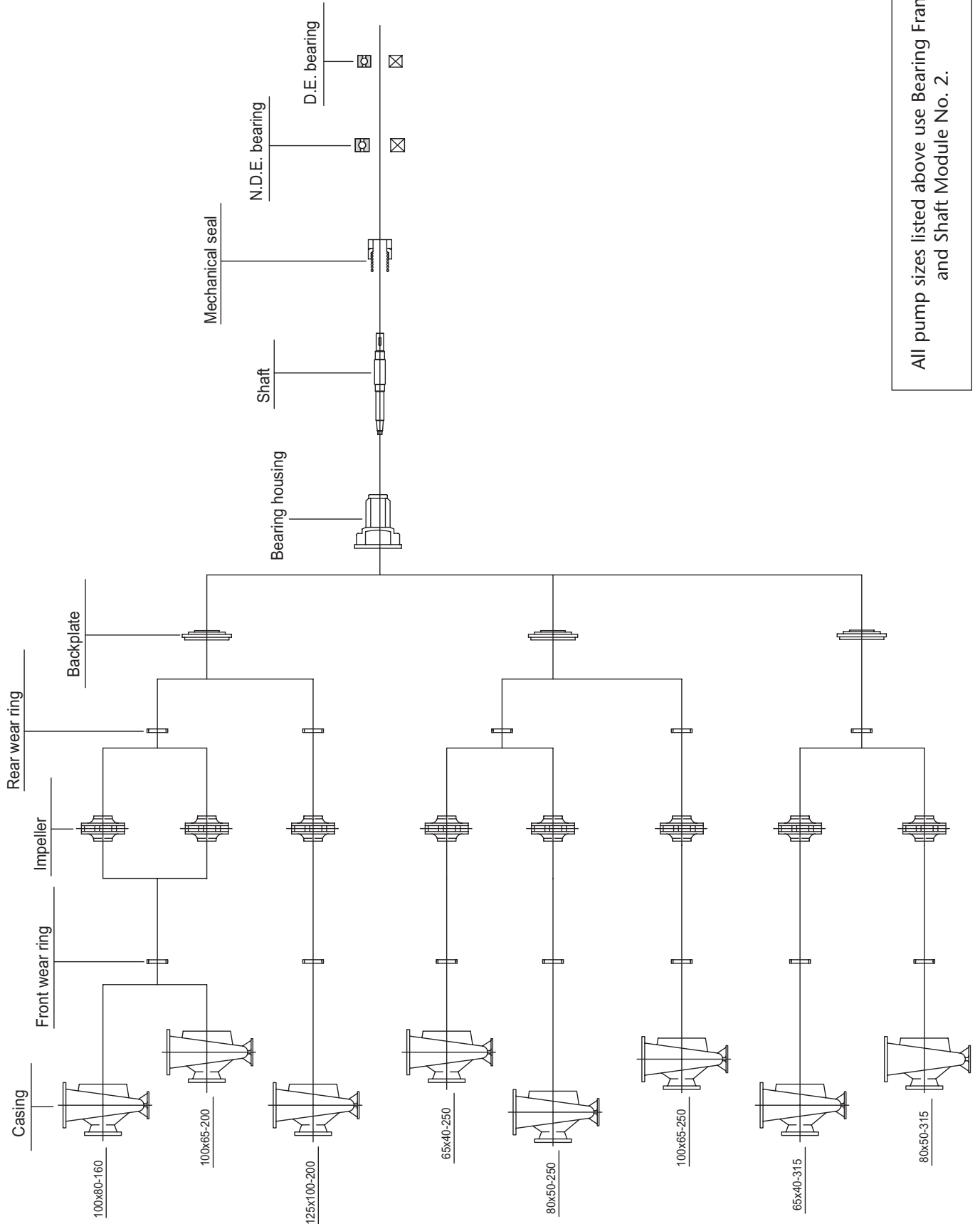

All pump sizes listed above use Bearing Frame and Shaft Module No. 2.

TECHNICAL SPECIFICATIONS

ISO **DAVEY**
spec

CF Series Shaft Module No. 3

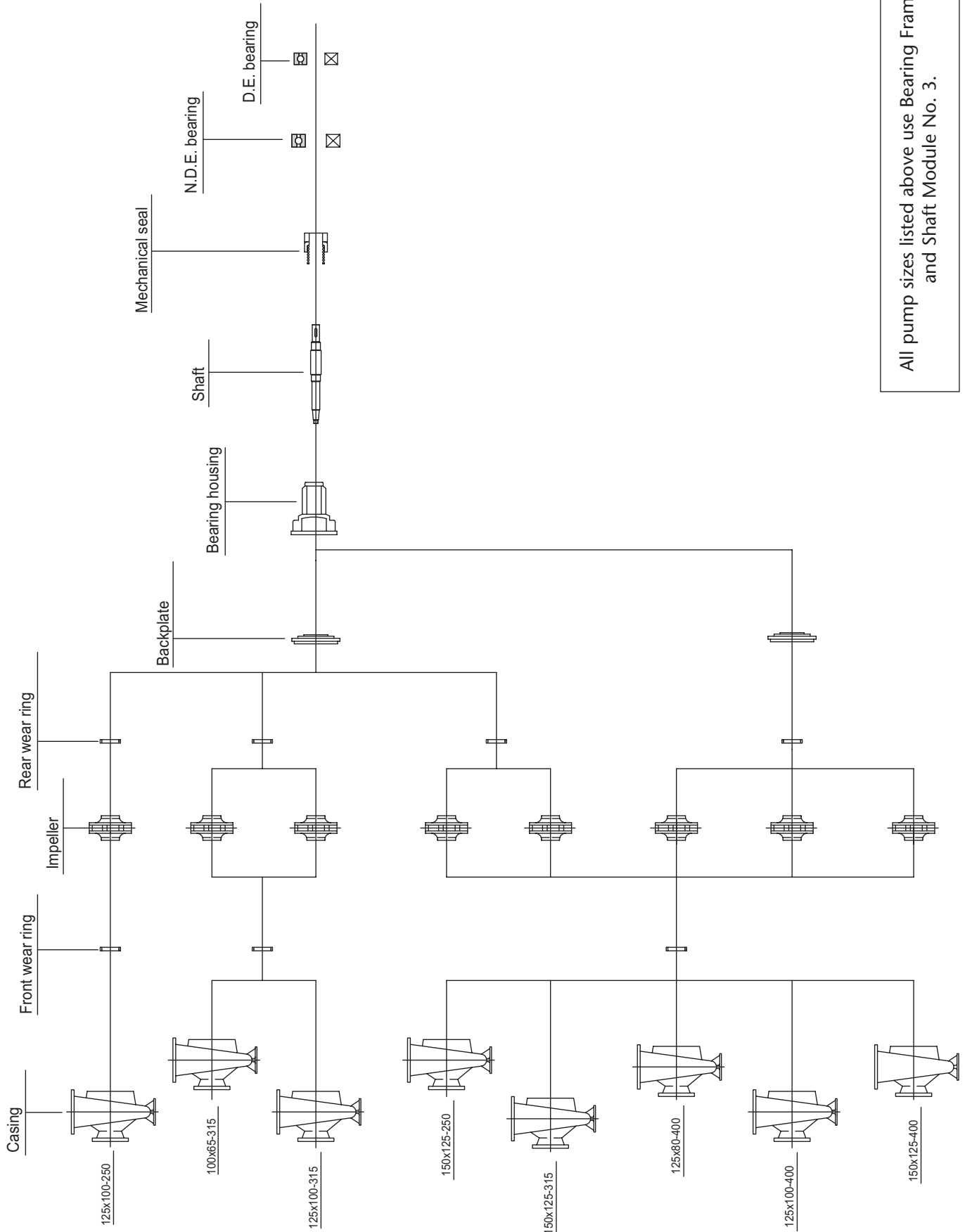

All pump sizes listed above use Bearing Frame and Shaft Module No. 3.

TECHNICAL SPECIFICATIONS



CF Series Shaft Module No. 4

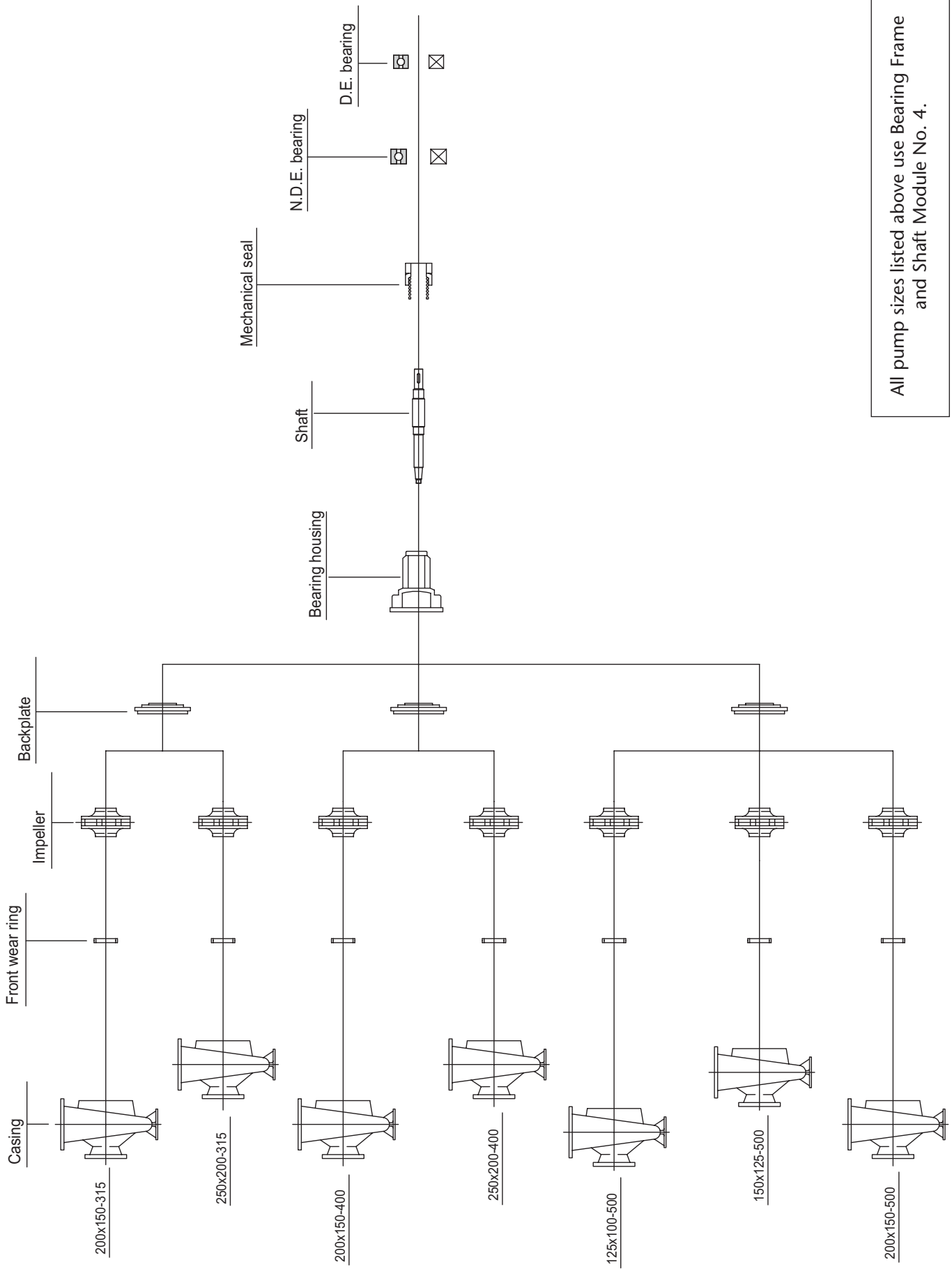

All pump sizes listed above use Bearing Frame and Shaft Module No. 4.

TECHNICAL SPECIFICATIONS

ISOspec ^{DAVEY}

CM Series Dimensions - 2 Pole

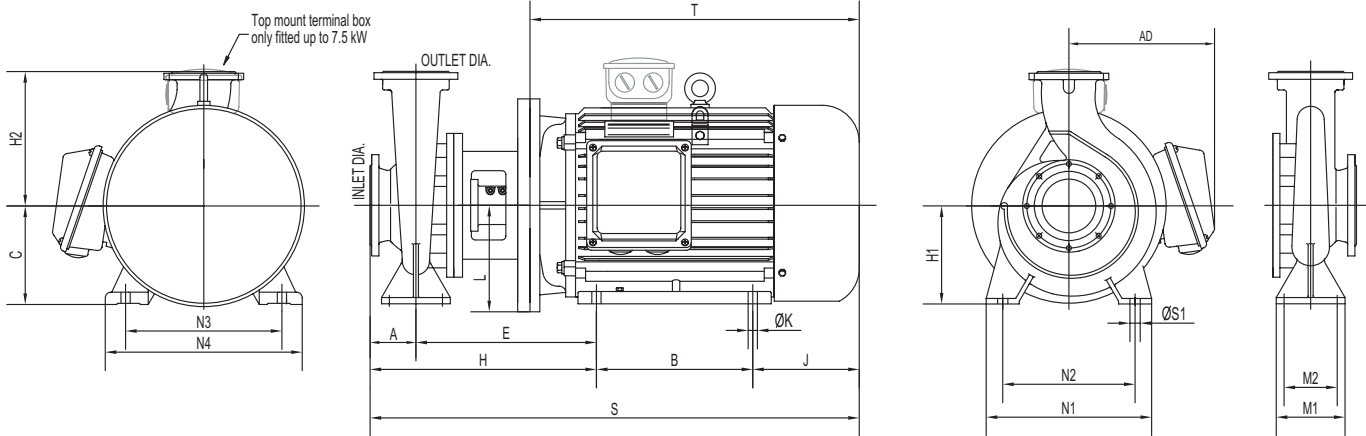

Pump End	In	Out	Imp	kW	Motor Frame	N3	B	C	E	H2	H	J	K	L	H1	N2	N1	S1	N4	S	T	M2	M1	AD	Kg		
50	32	160	3	100L	160	140	100	231	160	311	117	12	125	132	190	240	14	205	568	320	70	100	N/A	57			
			4	112M	190	140	112	238	160	318	130	12	125	132	190	240	14	245	588	340	70	100	N/A	60			
			5.5	132S	216	140	132	277	160	357	166	12	150	132	190	240	14	280	663	395	70	100	N/A	75			
50	32	200	5.5	132S	216	140	132	277	180	357	166	12	150	160	190	240	14	280	663	395	70	100	N/A	89			
			7.5	132S	216	140	132	277	180	357	166	12	150	160	190	240	14	280	663	395	70	100	N/A	89			
			11	160M	254	210	160	326	180	406	177	15	175	160	190	240	14	325	793	495	70	100	255	171			
65	50	160	4	112M	190	140	112	238	160	318	130	12	125	132	190	240	14	245	588	340	70	100	N/A	63			
			5.5	132S1	216	140	132	277	160	357	166	12	150	132	190	240	14	280	663	395	70	100	N/A	40			
			7.5	132S2	216	140	132	277	160	357	166	12	150	132	190	240	14	280	663	395	70	100	N/A	83			
65	40	200	7.5	132S	216	140	132	277	180	377	166	12	150	160	212	265	14	280	683	395	70	100	N/A	91			
			11	160M	254	210	160	326	180	426	177	15	175	160	212	265	14	325	813	495	70	100	255	166			
			15	160M	254	210	160	326	180	426	177	15	175	160	212	265	14	325	813	495	70	100	255	174			
65	40	250	11	160M	254	210	160	334	225	434	177	15	175	180	250	320	14	325	821	495	95	125	255	185			
			15	160M	254	210	160	334	225	434	177	15	175	180	250	320	14	325	821	495	95	125	255	194			
			18.5	160L	254	254	160	334	225	434	178	15	175	180	250	320	14	325	866	540	95	125	255	216			
			22	180M	279	241	180	347	225	447	198	15	175	180	250	320	14	355	886	560	95	125	270	251			
			30	200L	318	305	200	359	225	459	227	19	200	180	250	320	14	395	991	665	95	125	310	315			
65	40	315	22	180M	279	241	180	348	250	473	198	15	175	200	280	345	14	355	912	560	95	125	270	262			
			30	200L	318	305	200	360	250	485	227	19	200	200	280	345	14	395	1017	665	95	125	310	324			
			37	200L	318	305	200	360	250	485	227	19	200	200	280	345	14	395	1017	665	95	125	310	345			
			45	225M	356	311	225	376	250	501	245	19	225	200	280	345	14	435	1057	705	95	125	335	413			
80	65	160	5.5	132S	216	140	132	277	180	377	166	12	150	160	212	265	14	280	683	395	70	100	N/A	82			
			7.5	132S	216	140	132	277	180	377	166	12	150	160	212	265	14	280	683	395	70	100	N/A	88			
			11	160M	254	210	160	326	180	426	177	15	175	160	212	265	14	325	813	495	70	100	255	161			
			15	160M	254	210	160	326	180	426	177	15	175	160	212	265	14	325	813	495	70	100	255	173			
			11	160M	254	210	160	326	200	426	177	15	175	160	212	265	14	325	813	495	70	100	255	166			
80	50	200	18.5	160L	254	254	160	326	200	426	178	15	175	160	212	265	14	325	858	540	70	100	255	196			
			22	180M	279	241	180	339	200	439	198	15	175	160	212	265	14	355	878	560	70	100	270	230			
			80	50	250	18.5	160L	254	254	160	334.5	225	459.5	178	15	175	180	250	320	14	325	891.5	540	95	125	255	253
						22	180M	279	241	180	347.5	225	472.5	198	15	175	180	250	320	14	355	911.5	560	95	125	270	253
						30	200L	318	305	200	359.5	225	484.5	227	19	200	180	250	320	14	395	10165	665	95	125	310	316
80	50	315	37	200L	318	305	200	359.5	225	484.5	227	19	200	180	250	320	14	395	10165	665	95	125	310	336			
			45	225M	356	311	225	375.5	225	500.5	245	19	225	180	250	320	14	435	10565	705	95	125	335	404			
80	50	315	30	200L	318	305	200	360	280	485	227	19	200	225	280	345	14	395	1017	665	95	125	310	328			
			37	200L	318	305	200	360	280	485	227	19	200	225	280	345	14	395	1017	665	95	125	310	348			
			45	225M	356	311	225	376	280	501	245	19	225	225	280	345	14	435	1057	705	95	125	335	416			
			55	250M	406	349	250	425	280	550	273	24	275	225	280	345	14	490	1172	790	95	125	385	501			
			75	280S	457	368	280	447	280	572	302	24	275	225	280	345	14	545	1242	860	95	125	410	649			
100	80	160	11	160M	254	210	160	335	200	435	177	15	175	160	212	280	14	325	822	495	95	125	255	183			
			15	160M	254	210	160	335	200	435	177	15	175	160	212	280	14	325	822	495	95	125	255	191			
			18.5	160L	254	254	160	335	200	435	178	15	175	160	212	280	14	325	867	540	95	125	255	214			
			22	180M	279	241	180	348	200	448	198	15	175	160	212	280	14	325	887	560	95	125	270	227			

TECHNICAL SPECIFICATIONS



CM Series Dimensions - 2 Pole continued...

Pump End			kW	Motor Frame	N3	B	C	E	H2	H	J	K	L	H1	N2	N1	S1	N4	S	T	M2	M1	AD	Kg
In	Out	Imp																						
100	65	200	18.5	160L	254	254	160	335	225	435	178	15	175	180	250	320	14	325	867	540	95	125	255	214
			22	180M	279	241	180	348	225	448	198	15	175	180	250	320	14	355	887	560	95	125	270	248
			30	200L	318	305	200	360	225	460	227	19	200	180	250	320	14	395	992	665	95	125	310	310
			37	200L	318	305	200	360	225	460	227	19	200	180	250	320	14	395	992	665	95	125	310	310
100	65	250	30	200L	318	305	200	359.5	250	484.5	227	19	200	200	280	360	18	395	1016.5	665	120	160	310	311
			37	200L	318	305	200	359.5	250	484.5	227	19	200	200	280	360	18	395	1016.5	665	120	160	310	331
			45	225M	356	311	225	375.5	250	500.5	245	19	225	200	280	360	18	435	1056.5	705	120	160	335	400
			55	250M	406	349	250	424.5	250	549.5	273	24	275	200	280	360	18	490	1171.5	790	120	160	385	487
			75	280S	457	368	280	446.5	250	571.5	302	24	275	200	280	360	18	545	1241.5	860	120	160	410	635
100	65	315	55	250M	406	349	250	450	280	575	273	24	275	225	315	400	18	490	1197	790	120	160	385	529
			75	280S	457	368	280	472	280	597	302	24	275	225	315	400	18	545	1267	860	120	160	410	680
			90	280M	457	419	280	472	280	597	301	24	275	225	315	400	18	545	1317	910	120	160	410	745
			110	315S	508	406	315	498	280	623	478	28	330	225	315	400	18	744	1507	1100	120	160	530	1115
125	100	200	30	200L	318	305	200	360	280	485	227	19	200	200	280	360	18	395	1017	665	120	160	310	320
			37	200L	318	305	200	360	280	485	227	19	200	200	280	360	18	395	1017	665	120	160	310	340
			45	225M	356	311	225	376	280	501	245	19	225	200	280	360	18	435	1057	705	120	160	335	410
			55	250M	406	349	250	425	280	550	273	24	275	200	280	360	18	490	1172	790	120	160	385	499
			75	280S	457	368	280	447	280	572	302	24	275	200	280	360	18	545	1242	860	120	160	410	645
125	100	250	55	250M	406	349	250	450	280	590	273	24	275	225	315	400	18	490	1212	790	120	160	385	532
			75	280S	457	368	280	472	280	612	302	24	275	225	315	400	18	545	1282	860	120	160	410	680
			90	280M	457	419	280	472	280	612	301	24	275	225	315	400	18	545	1332	910	120	160	410	745
			110	315S	508	406	315	498	280	638	478	28	330	225	315	400	18	744	1522	1100	120	160	530	1117
125	100	315	90	280M	457	419	280	472	315	612	301	24	275	250	315	400	18	545	1332	910	120	160	410	745
			110	315S	508	406	315	498	315	638	478	28	330	250	315	400	18	628	1522	1100	120	160	530	1230

- Notes:
1. Standard flange drilling to AS2129 Table E: 16 bar rating.
 2. Dimensions in mm.
 3. All motors listed are 415V. Other voltages are available upon request.
 4. All motors up to 7.5kW have top mounted terminal box.

N/A = Not Applicable

TECHNICAL SPECIFICATIONS

ISOspec ^{DAVEY}

CM Series Dimensions - 4 Pole

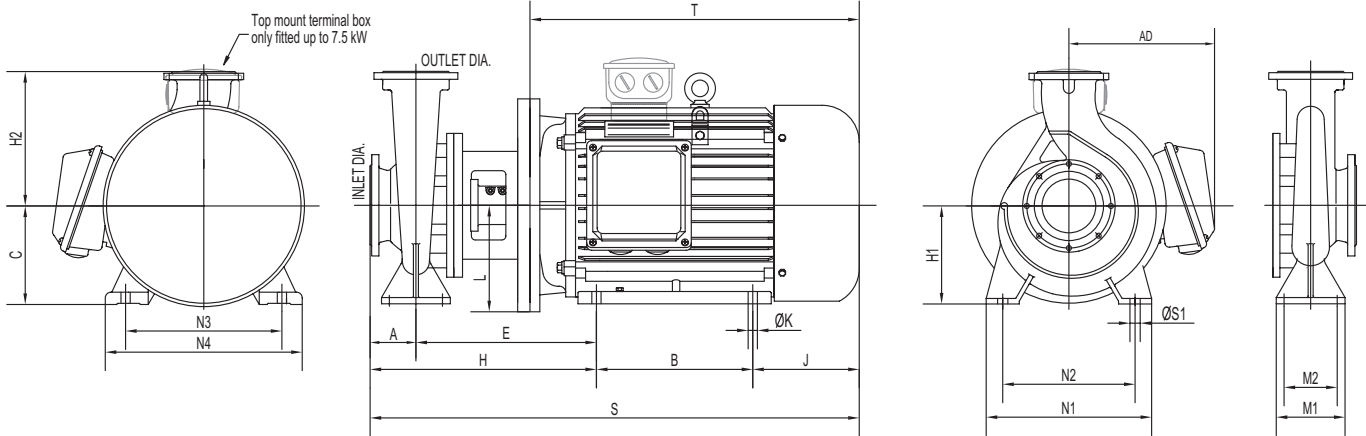

Pump End In	Pump End Out	Pump End Imp	kW	Motor Frame	N3	B	C	E	H2	H	J	K	L	H1	N2	N1	S1	N4	S	T	M2	M1	AD	Kg
50	32	200	1.1	90S	140	100	90	209	180	289	104	10	100	160	190	240	14	180	493	260	70	100	N/A	54
			1.5	90L	140	125	90	209	180	289	104	10	100	160	190	240	14	180	518	285	70	100	N/A	55
65	50	160	1.1	90S	140	100	90	209	160	289	104	10	100	132	190	240	14	180	493	260	70	100	N/A	47
65	40	200	1.1	90S	140	100	90	209	180	309	104	10	100	160	212	265	14	180	513	260	70	100	N/A	55
			1.5	90L	140	125	90	209	180	309	104	10	100	160	212	265	14	180	538	285	70	100	N/A	56
			2.2	100L	160	140	100	231	180	331	117	12	125	160	212	265	14	205	588	320	70	100	N/A	67
65	40	250	1.5	90L	140	125	90	218	225	318	104	10	100	180	250	320	14	180	547	285	95	125	N/A	77
			2.2	100L	160	140	100	239	225	339	117	12	125	180	250	320	14	205	596	320	95	125	N/A	89
			3	100L	160	140	100	239	225	339	117	12	125	180	250	320	14	205	596	320	95	125	N/A	91
65	40	315	3	100L	160	140	100	240	250	365	117	12	125	200	280	345	14	205	622	320	95	125	N/A	100
			4	112M	190	140	112	247	250	372	130	12	125	200	280	345	14	245	642	340	95	125	N/A	105
			5.5	132S	216	140	132	286	250	411	166	12	150	200	280	345	14	280	717	395	95	125	N/A	125
80	65	160	1.1	90S	140	100	90	209	180	309	104	10	100	160	212	265	14	180	513	260	70	100	N/A	54
			1.5	90L	140	125	90	209	180	309	104	10	100	160	212	265	14	180	538	285	70	100	N/A	55
80	50	200	1.5	90L	140	125	90	209	200	309	104	10	100	160	212	265	14	180	538	285	70	100	N/A	59
			2.2	100L	160	140	100	231	200	331	117	12	125	160	212	265	14	205	588	320	70	100	N/A	69
			3	100L	160	140	100	231	200	331	117	12	125	160	212	265	14	205	588	320	70	100	N/A	71
80	50	250	3	100L	160	140	100	239.5	225	364.5	117	12	125	180	250	320	14	205	621.5	320	95	125	N/A	91
			4	112M	190	140	112	246.5	225	371.5	130	12	125	180	250	320	14	245	641.5	340	95	125	N/A	95
			5.5	132S	216	140	132	285.5	225	410.5	166	12	150	180	250	320	14	280	716.5	395	95	125	N/A	114
80	50	315	4	112M	190	140	112	247	280	372	130	12	125	225	280	345	14	245	642	340	95	125	N/A	108
			5.5	132S	216	140	132	286	280	411	166	12	150	225	280	345	14	280	717	395	95	125	N/A	128
			7.5	132M	216	178	132	286	280	411	168	12	150	225	280	345	14	280	757	435	95	125	N/A	138
			11	160M	216	178	132	286	280	411	168	12	150	225	280	345	14	280	757	435	95	125	255	206
100	80	160	1.5	90L	140	125	90	219	200	319	104	10	100	160	212	280	14	180	548	285	95	125	N/A	76
			2.2	100L	160	140	100	240	200	340	117	12	125	160	212	280	14	205	597	320	95	125	N/A	86
			3	100L	160	140	100	240	200	340	117	12	125	160	212	280	14	205	597	320	95	125	N/A	88
			2.2	100L	160	140	100	240	225	340	117	12	125	180	250	320	14	205	597	320	95	125	N/A	87
100	65	200	3	100L	160	140	100	240	225	340	117	12	125	180	250	320	14	205	597	320	95	125	N/A	89
			4	112M	190	140	112	247	225	347	130	12	125	180	250	320	14	245	617	340	95	125	N/A	92
			5.5	132S	216	140	132	286	225	386	166	12	150	180	250	320	14	280	692	395	95	125	N/A	110
100	65	250	4	112M	190	140	112	246.5	250	371.5	130	12	125	200	280	360	18	245	641.5	340	120	160	N/A	94
			5.5	132S	216	140	132	285.5	250	410.5	166	12	150	200	280	360	18	280	716.5	395	120	160	N/A	113
			7.5	132M	216	178	132	285.5	250	410.5	168	12	150	200	280	360	18	280	756.5	435	120	160	N/A	123
100	65	315	7.5	132M	216	178	132	311	280	436	168	12	150	225	315	400	18	280	782	435	120	160	N/A	186
			11	160M	254	210	160	360	280	485	177	15	175	225	315	400	18	325	872	495	120	160	255	238
			15	160L	254	254	160	360	280	485	178	15	175	225	315	400	18	325	917	540	120	160	255	259
125	100	200	4	112M	190	140	112	247	280	372	130	12	125	200	280	360	18	245	642	340	120	160	N/A	102
			5.5	132S	216	140	132	286	280	411	166	12	150	200	280	360	18	280	717	395	120	140	N/A	121
			7.5	132M	216	178	132	286	280	411	168	12	150	200	280	360	18	280	757	435	120	160	N/A	131

TECHNICAL SPECIFICATIONS



CM Series Dimensions - 4 Pole continued...

Pump End			kW	Motor Frame	N3	B	C	E	H2	H	J	K	L	H1	N2	N1	S1	N4	S	T	M2	M1	AD	Kg
In	Out	Imp																						
125	100	250	7.5	132M	216	178	132	311	280	451	168	12	150	225	315	400	18	280	797	435	120	160	N/A	173
			11	160M	254	210	160	360	280	500	177	15	175	225	315	400	18	325	887	495	120	160	255	246
			15	160L	254	254	160	360	280	500	178	15	175	225	315	400	18	325	932	540	120	160	255	267
125	100	315	11	160M	254	210	160	360	315	500	177	15	175	250	315	400	18	325	887	495	120	160	255	252
			15	160L	254	254	160	360	315	500	178	15	175	250	315	400	18	325	932	540	120	160	255	273
			18.5	180M	279	241	180	373	315	513	198	15	175	250	315	400	18	355	952	560	120	160	270	314
			22	180L	279	279	180	373	315	513	200	15	175	250	315	400	18	355	992	600	120	160	270	322

- Notes:
1. Standard flange drilling to AS2129 Table E: 16 bar rating.
 2. Dimensions in mm.
 3. All motors listed are 415V.
 4. All motors up to 7.5kW have top mounted terminal box.

N/A = Not Applicable

TECHNICAL SPECIFICATIONS

ISO **DAVEY**
spec®

CM Series Shaft Module No. 1

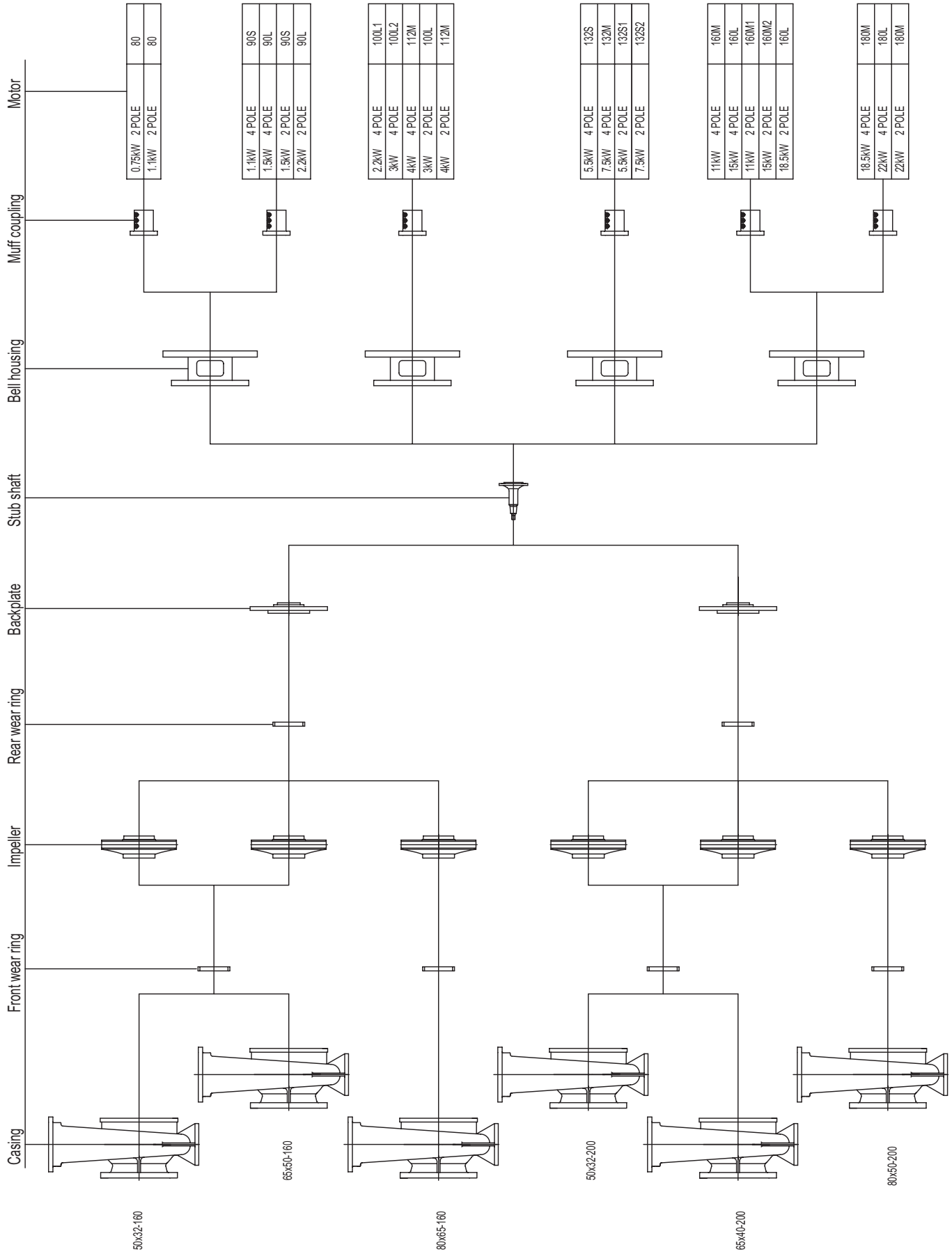

TECHNICAL SPECIFICATIONS



CM Series Shaft Module No. 2

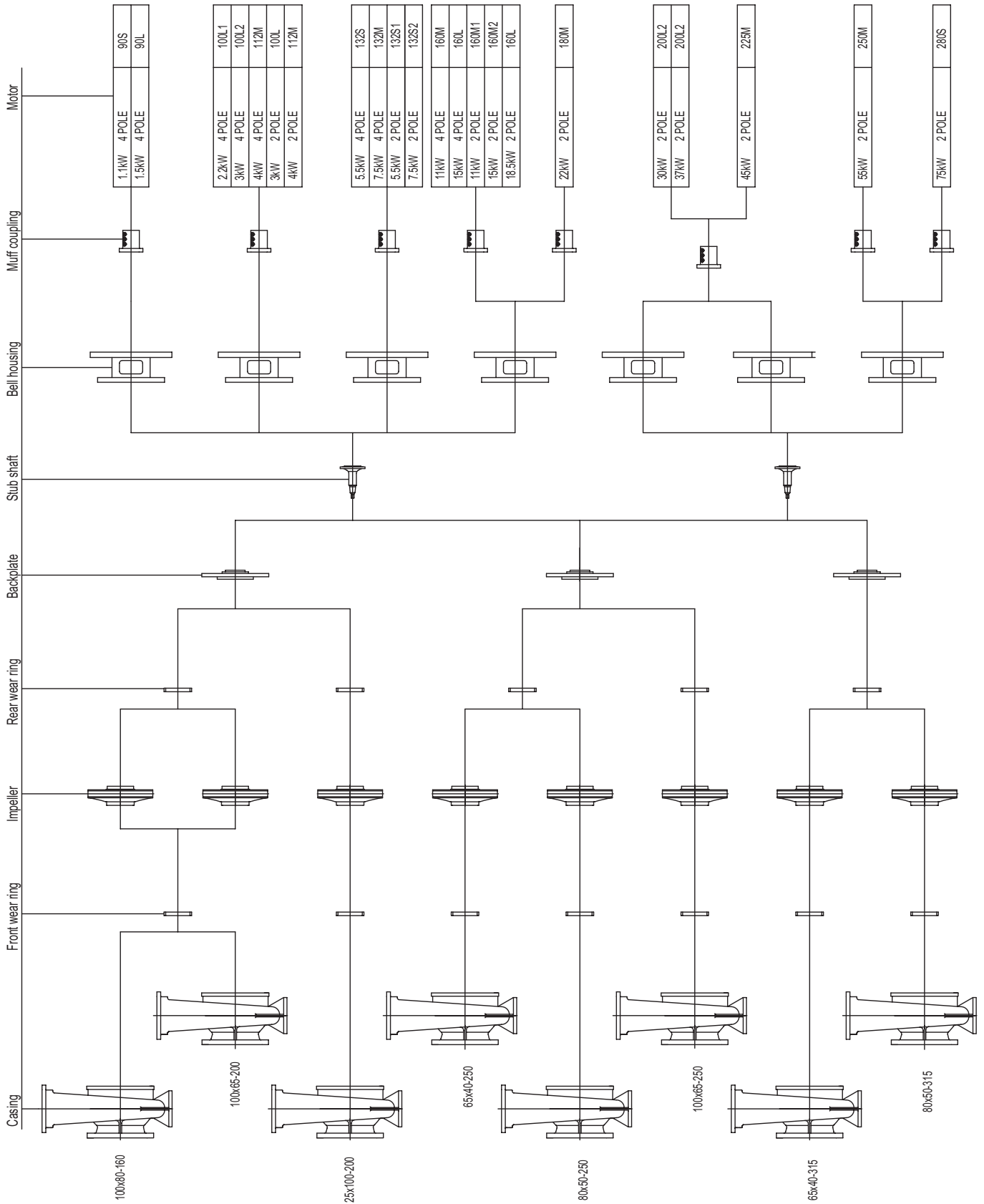

TECHNICAL SPECIFICATIONS

ISO **DAVEY**
spec

CM Series Shaft Module No. 3

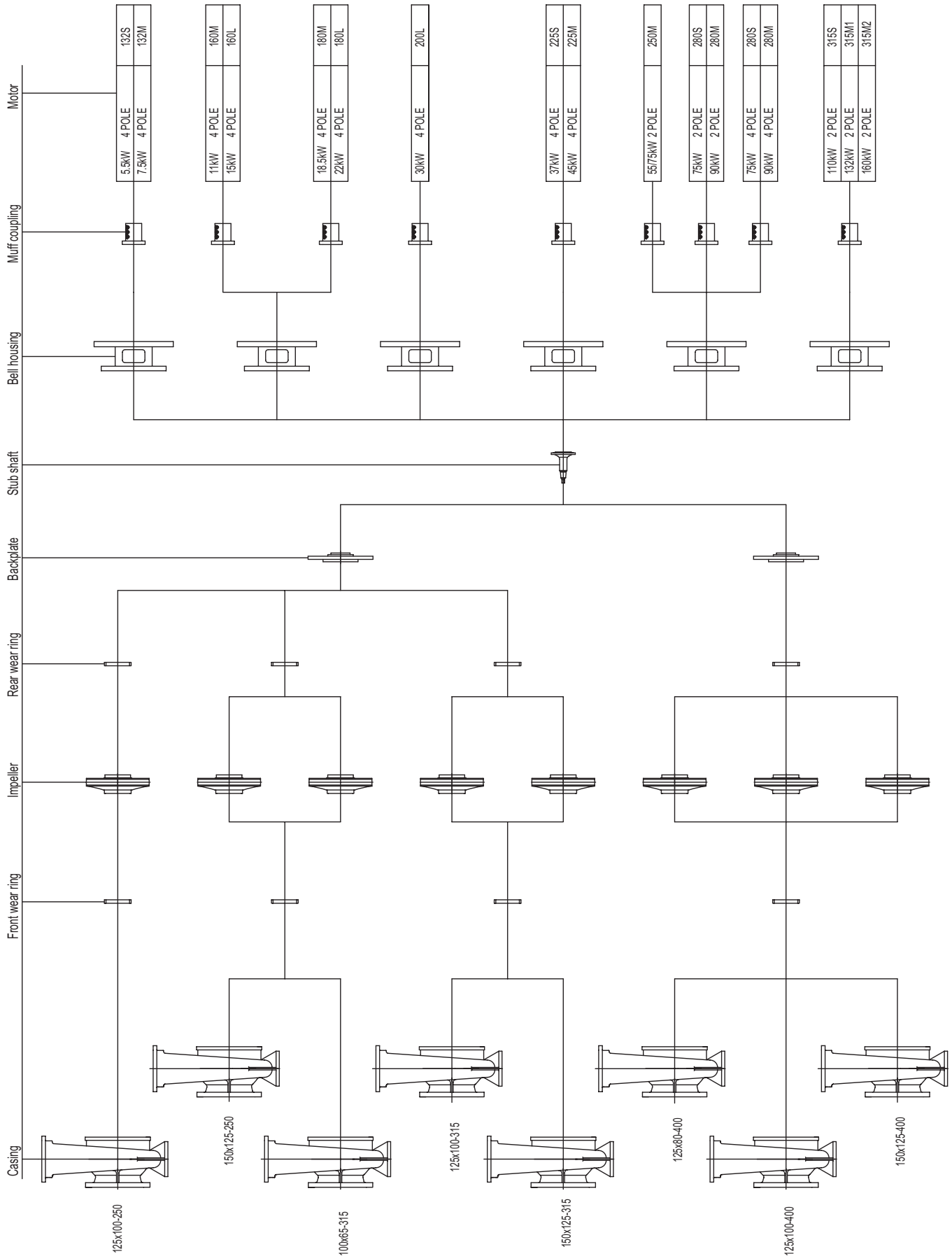

TECHNICAL SPECIFICATIONS



CF & CM Series Seal Cavity Dimensions

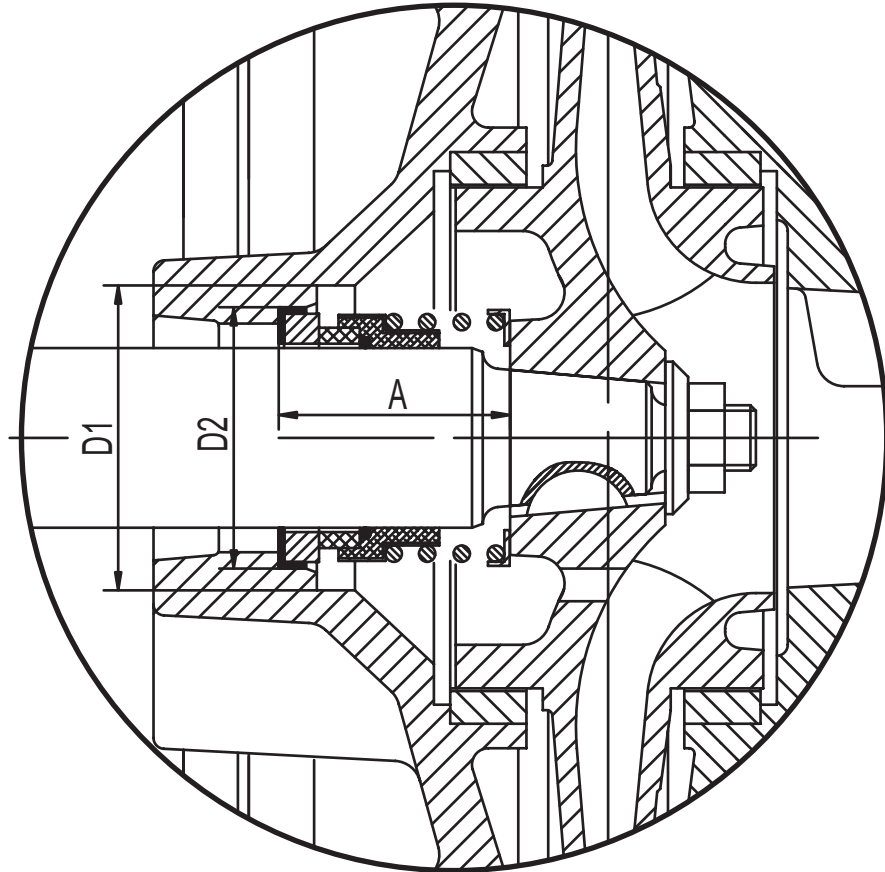

Module	Seal size	D1	D2	A
No. 1	32	56	48	42.5
No. 2	43	68	61	45
No. 3	53	90	73	47.5
No. 4 *	60	92	80	52.5

All dimensions in mm, unless otherwise stated.

*CM Series not available.

TECHNICAL SPECIFICATIONS



Material Specifications

STANDARD CONSTRUCTION				
Component	Standard Fitted Pump	Australian Standard	British Standard	ASTM Standard
Casing	Cast iron GG25	AS1830/T260	BS1452 - Gr260	A48-Class 35
Back Plate	Cast iron GG25	AS1830/T260	BS1452 - Gr260	A48-Class 35
Bearing Housing (CF)	Cast iron GG20	AS1830/T220	BS1452 - Gr220	A48-Class 30
Casing Wear Ring	Bronze	AS1565/836	BS1400 LG2	B584-C83600
Impeller	Bronze	AS1565/836	BS1400 LG2	B584-C83600
Impeller Key	Stainless steel 420	AS1444/420	BS970 - Gr420-S37	A276 - type 420
Impeller Lock Nut	Stainless steel 420	AS1444/420	BS970 - Gr420-S37	A276 - type 420
Shaft (CF) (CM)	Stainless steel 420 Stainless steel 316	AS1444/420 AS2074/H6B	BS970 - Gr420-S37 BS1504 - Gr316	A276 - type 420 A351-CF-8M

OPTIONAL MATERIAL CONSTRUCTION				
Component	Optional Materials	Australian Standard	British Standard	ASTM Standard
Casing	Ductile iron Stainless steel 304 Stainless steel 316	AS 1831/400 AS 2074/H5C AS 2074/H6B	BS2789-Gr500/7 BS1504-Gr304 BS1504-Gr316	A536-84 70-50-05 A351-CF-8 A351-CF-8M
Back Plate	Ductile iron Stainless steel 304 Stainless steel 316	AS 1831 AS 2074/H5C AS 2074/H6B	BS2789-Gr500/7 BS1504-Gr304 BS1504-Gr316	A536-84 70-50-05 A351-CF-8 A351-CF-8M
Casing Wear Ring	Stainless steel 304 Stainless steel 316	AS 2074/H5C AS 2074/H6B	BS1504-Gr304 BS1504-Gr316	A351-CF-8 A351-CF-8M
Impeller	Stainless steel 304 Stainless steel 316	AS 2074/H5C AS 2074/H6B	BS1504-Gr304 BS1504-Gr316	A351-CF-8 A351-CF-8M
Impeller Lock Nut	Stainless steel 304	AS 2074/H5C	BS1504-Gr304	A351-CF-8
Shaft (CF)	Stainless steel 316	AS 1444/316	BS970-Gr316-S16	A276 type 316

Other materials available upon request, please contact Davey.



Visit Davey Pumps on-line for further information
www.davey.com.au

© Davey Products Pty Ltd
® Davey and ISOspec are registered trademarks of Davey Products Pty Ltd.

Note: This literature is not a complete guide to product usage. Further information is available from your Davey Customer Service Centre and from the relevant product Installation and Operating Instructions.
Information & specifications subject to change without notice.

Your Authorised Davey Dealer

DEPEND ON
DAVEY
PUMPS

Davey Products Pty Ltd

Member of the GUD Holdings Ltd Group

ABN 18 066 327 517

Head Office and Manufacturing

6 Lakeview Drive,
Scoresby, Australia 3179

Ph: +61 3 9730 9222

Fax: +61 3 9753 4100

Website: www.davey.com.au

Customer Service Centre

Ph: 1300 367 866

Fax: 1300 369 119

E-mail: sales@davey.com.au

Interstate Offices

Sydney - Brisbane - Adelaide

Perth - Townsville

International

6 Lakeview Drive,
Scoresby, Australia 3179

Ph: +61 3 9730 9121

Fax: +61 3 9753 4248

E-mail: export@davey.com.au

Germany

Kantstrasse 47,
04275 Leipzig

Ph: +49 341 301 0412

Fax: +49 341 301 0413

E-mail: DaveyEurop@aol.com

New Zealand

220A Bush Road,
North Harbour, Auckland 1330

Ph: +64 9 914 3680

Fax: +64 9 914 3685

Website: www.daveynz.co.nz

E-mail: sales@daveynz.co.nz

USA

1005 N. Commons Drive
Aurora, Illinois 60504

Ph: +1 630 898 6976

Fax: +1 630 851 7744

Website: www.daveyusa.com

E-mail: sales@daveyusa.com